

RYLE Manufacturing Company 1-800-433-0960

Type B No. 80 1" Pitch Type A

RYLE P/N	LIST PRICE	NO. TEETH	O.D. TEETH	STOCK BORE	MAX BORE	HUB DIA.	LTB	LBS.	RYLE P/N	LIST PRICE	LBS.
80B8	48.60	8	3.01	1	1	1-7/8 *	1-5/8	1.4	80A8	37.20	1.0
80B9	48.60	9	3.35	1	1-5/16	2-1/4 *		1.6	80A9	37.20	1.2
80B10	53.00	10	3.68	1	1-1/2	2-9/16 *		1.7	80A10	38.00	1.6
80B11	58.40	11	4.01	1	1-5/8	2-13/16 *		2.3	80A11	39.60	1.8
80B12	62.80	12	4.33	1	1-7/8	3-1/8 *		3.0	80A12	41.00	2.0
80B13	67.60	13	4.66	1	2	3	1-1/2	3.5	80A13	44.40	2.3
80B14	71.80	14	4.98	1	2-1/4	3-1/4		4.1	80A14	45.40	2.7
80B15	76.20	15	5.30	1	2-1/2	3-13/16		5.2	80A15	47.20	3.0
80B16	85.80	16	5.63	1	2-3/4	4		6.1	80A16	50.40	3.4
80B17	96.80	17	5.95	1				7.0	80A17	53.00	4.0
80B18	109.00	18	6.27	1	3	4-1/4		7.5	80A18	56.00	4.4
80B19	125.40	19	6.59	1				8.0	80A19	58.80	4.7
80B20	134.00	20	6.91	1				8.0	80A20	61.80	5.4
80B21	145.20	21	7.21	1			1-3/4	11.2	80A21	65.60	5.8
80B22	150.00	22	7.56	1				11.8	80A22	69.00	6.2
80B23	156.80	23	7.88	1				12.0	80A23	71.80	6.7
80B24	160.00	24	8.20	1				14.0	80A24	74.80	7.6
80B25	163.00	25	8.52	1				14.9	80A25	77.60	8.0
80B26	168.20	26	8.81	1				15.0	80A26	80.00	8.7
80B27	178.80	27	9.16	1	3-1/4	4-3/4	2	16.5	80A27	91.60	9.5
80B28	181.40	28	9.48	1				17.5	80A28	92.00	10.1
80B29	186.20	29	9.80	1				18.2	80A29	93.60	10.6
80B30	190.00	30	10.11	1				19.0	80A30	94.40	11.3
80B31	200.00	31	10.43	1				19.5	80A31	100.40	12.0
80B32	201.60	32	10.75	1				20.0	80A32	101.80	12.8
80B33	216.00	33	11.07	1				21.0	80A33	113.40	13.4
80B34	217.40	34	11.39	1				22.0	80A34	123.00	14.5
80B35	219.00	35	11.71	1				23.0	80A35	125.40	15.4
80B36	225.20	36	12.03	1				24.0	80A36	130.20	16.0
80B37	237.60	37	12.35	1				24.5	80A37	137.40	16.8
80B38	250.60	38	12.67	1				25.2	80A38	149.40	17.5
80B39	256.20	39	12.99	1				26.0	80A39	154.20	18.8
80B40	253.60	40	13.31	1				27.0	80A40	156.80	19.6
80B41	259.40	41	13.63	1-1/4				27.7	80A41	164.00	20.3
80B42	260.80	42	13.91					28.6	80A42	166.40	21.2
80B43	272.00	43	14.26					29.0	80A43	178.40	22.4
80B44	288.40	44	14.58					30.0	80A44	195.20	23.5
80B45	292.20	45	14.90					31.5	80A45	197.60	24.8
80B46	300.80	46	15.22					32.8	80A46	221.80	26.0
80B47	315.80	47	15.54					33.8	80A47	224.20	26.7
80B48	318.60	48	15.86					34.8	80A48	226.60	27.5
80B49	344.20	49	16.18					36.5	80A49	274.80	29.0
80B50	347.60	50	16.50					39.0	80A50	277.20	30.3
80B51	351.20	51	16.81					39.5	80A51	279.60	31.5
80B52	354.80	52	17.13					41.0	80A52	282.00	32.7
80B53	358.40	53	17.45					42.0	80A53	282.00	33.8
80B54	362.00	54	17.77		3-1/2	5-1/4		43.0	80A54	284.40	35.0
80B55	375.20	55	18.08					44.0	80A55	294.20	37.5
80B56	388.60	56	18.41					45.7	80A56	301.40	38.4
80B57	402.00	57	18.73					46.0	80A57	308.60	40.4
80B58	415.20	58	19.04					50.0	80A58	318.20	41.3
80B59	428.40	59	19.36					52.0	80A59	332.80	41.9
80B60	441.80	60	19.68					54.0	80A60	340.00	42.0
80B65	558.00	65	21.27		4-1/4	6-1/4	3-1/2	61.8	80A65	436.40	52.2
80C70	579.60	70	22.87	1-1/2				75.0	80A70	453.20	61.5
80C72	623.00	72	23.50					82.0	80A72	467.60	65.0
80C76	695.20	76	24.78					87.8	80A76	540.00	70.2
80C80	717.00	80	26.05					92.0	80A80	556.80	81.0
80C84	789.40	84	27.33					100.0	80A84	619.60	90.0
80C90	912.80	90	29.21					116.0	80A90	778.60	101.0
80C96	941.80	96	31.15					152.0	80A96	802.80	119.0
80C112	1315.40	112	36.24					170.0	80A112	1203.00	141.0

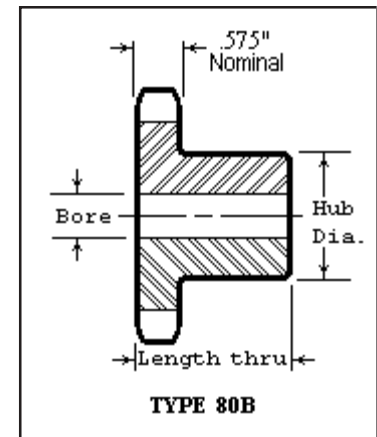
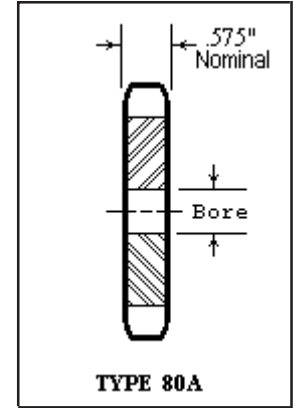

* Indicates hub diameter is grooved for chain clearance.

Maximum bores will accommodate standard keyway and setscrew over key. Slightly larger bores may be possible with shallow keyway and/or setscrew at 90 degrees.

Multiple keyways must be priced at factory.

Split Type A plate	\$ 3.42
per inch of sprocket diameter	
Rebore	\$49.00
Keyway	\$13.40
Setscrew (each)	\$13.40
Harden per tooth	\$ 1.78
Drill Type A plate	(4) holes = \$28.00
	(6) holes = \$42.00
	(8) holes = \$56.00



RYLE Manufacturing Company 1-800-433-0960

No. 80 1" Pitch

Stainless Steel

RYLE P/N	LIST PRICE	NO. TEETH	O.D. TEETH	STOCK BORE	MAX BORE	HUB DIA.	LTB	LBS.
80B10SS	295.00	10	3.68	1	1-1/2	2-9/16*	1-5/8	1.7
80B11SS	365.00	11	4.01	1	1-5/8	2-13/16*		2.3
80B12SS	405.00	12	4.33	1	1-7/8	3-1/8*		3.0
80B13SS	462.00	13	4.66	1	2	3	1-1/2	3.5
80B14SS	535.00	14	4.98	1	2-1/4	3-1/4		4.1
80B15SS	618.00	15	5.30	1	2-1/2	3-13/16		5.2
80B16SS	654.00	16	5.63	1	2-3/4	4		6.1
80B17SS	732.00	17	5.95	1				7.0
80B18SS	815.00	18	6.27	1	3	4-1/4		7.8
80B19SS	865.00	19	6.59	1				9.0
80B20SS	975.00	20	6.91	1				10.5

* Indicates hub diameter is grooved for chain clearance.
 Maximum bores will accommodate standard keyway and setscrew over key.
 Slightly larger bores may be possible with shallow keyway and/or setscrew at 90 degrees.
 Multiple keyways must be priced at factory.

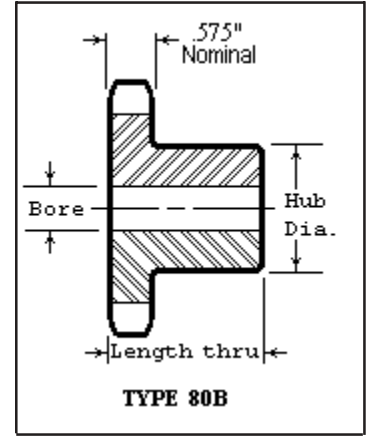

Rebore	\$49.00
Keyway	\$13.40
Setscrew (each)	\$13.40

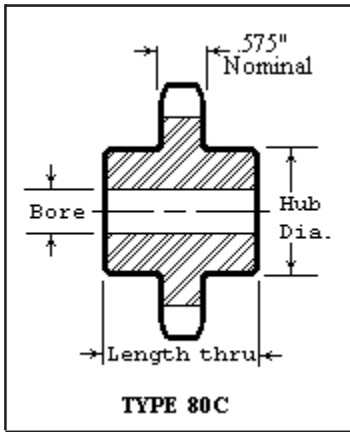

Type C

RYLE P/N	LIST PRICE	NO. TEETH	O.D. TEETH	STOCK BORE	MAX BORE	HUB DIA.	LTB	LBS.
80C11	160.00	11	4.00	1	1-5/8	2-1/2	2-3/8	3.9
80C12	164.40	12	4.33	1	1-7/8	2-3/4		4.3
80C13	179.40	13	4.65	1	2	3-1/8		5.3
80C14	209.80	14	4.98	1	2-1/4	3-3/8		6.4
80C15	230.00	15	5.30	1	2-1/2	3-13/16		7.8
80C16	246.00	16	5.62	1	2-3/4	4		8.8

Hub projection is centered

Rebore	\$49.00
Keyway	\$13.40
Setscrew (each)	\$13.40
Harden per tooth	\$ 1.78

RYLE P/N	LIST PRICE
80B9H	66.00
80B10H	73.20
80B11H	79.60
80B12H	85.80
80B13H	92.60
80B14H	98.80
80B15H	105.20
80B16H	116.60
80B17H	130.00
80B18H	143.60
80B19H	158.00
80B20H	172.60

Type B Hard Teeth

Double-Single

RYLE P/N	LIST PRICE	TEETH O.D.	STOCK BORE	MAX BORE	LTB	HUB DIA.	LBS.
DS80A13	217.00	4.66	1	2	2-3/16	3-1/64	6.5
DS80A14	248.20	4.98	1	2-1/4		3-11/32	7.7
DS80A15	267.60	5.30	1	2-3/8		3-13/16	9.1
DS80A16	272.40	5.63	1	2-11/16		4	9.5
DS80A17	279.60	5.95	1	2-13/16		4-5/16	10.8
DS80A18	286.80	6.27	1	3-1/8		4-41/64	12.1
DS80A19	299.00	6.59	1	3-1/4		4-61/64	12.8
DS80A20	313.40	6.91	1	3-1/2		5-9/32	14.0
DS80A21	330.40	7.24	1	3-3/4		5-19/32	16.5
DS80A22	344.80	7.56	1	3-7/8	2-3/16	5-59/64	18.4

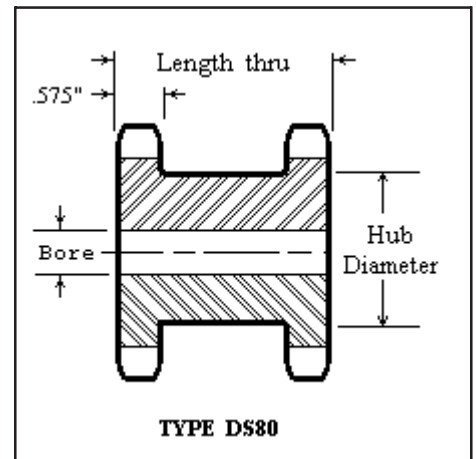

RYLE Manufacturing Company 1-800-433-0960

No. 80 1" Pitch Bored to Size & Winch

RYLE P/N	LIST PRICE	NO. TEETH	O.D. TEETH	LBS.	AVAILABLE BORE SIZES WITH STANDARD KEYWAY AND (2) SETSCREWS												
80BS9	41.40	9	3.35	1.6	1	1-1/8	1-3/16	1-1/4									
80BS10	58.80	10	3.69	1.7	1	1-1/8	1-3/16	1-1/4									
80B10W	58.80	10W	3.69	1.7				1-1/4									
80BS11	65.60	11	4.01	2.3	1	1-1/8	1-3/16	1-1/4	1-3/8	1-7/16	1-1/2	1-5/8					
80B11W	65.60	11W	4.01	2.3				1-1/4									
80BS12	73.80	12	4.33	3.0	1	1-1/8	1-3/16	1-1/4	1-3/8	1-7/16	1-1/2	1-5/8	1-3/4				
80B12W	73.80	12W	4.33	3.0				1-1/4			1-1/2						
80BS13	81.40	13	4.66	3.5	1	1-1/8	1-3/16	1-1/4	1-3/8	1-7/16	1-1/2	1-5/8	1-3/4	1-7/8	1-15/16	2	
80BS14	89.60	14	4.98	4.1	1	1-1/8	1-3/16	1-1/4	1-3/8	1-7/16	1-1/2	1-5/8	1-3/4	1-7/8	1-15/16	2	
80BS15	95.60	15	5.30	5.2	1	1-1/8	1-3/16	1-1/4	1-3/8	1-7/16	1-1/2	1-5/8	1-3/4	1-7/8	1-15/16	2	
80B15W	95.60	15W	5.30	5.2				1-1/4			1-1/2						
80BS16	104.20	16	5.63	6.1	1		1-3/16	1-1/4	1-3/8	1-7/16	1-1/2	1-5/8	1-3/4		1-15/16	2	
80BS17	124.80	17	5.95	7.0	1		1-3/16	1-1/4	1-3/8	1-7/16	1-1/2	1-5/8	1-3/4		1-15/16	2	
80BS18	133.20	18	6.27	7.8	1		1-3/16	1-1/4	1-3/8	1-7/16	1-1/2	1-5/8	1-3/4		1-15/16	2	2-7/16
80B18W	133.20	18W	6.27	7.8				1-1/4			1-1/2						
80BS19	141.80	19	6.59	8.0	1		1-3/16	1-1/4	1-3/8	1-7/16	1-1/2	1-5/8	1-3/4		1-15/16	2	2-7/16
80BS20	150.40	20	6.91	8.0	1			1-1/4	1-3/8	1-7/16	1-1/2	1-5/8	1-3/4		1-15/16	2	2-7/16
80B20W	150.40	20W	6.91	6.5				1-1/4			1-1/2						
80B21W	156.80	21W	7.21	7.0				1-1/4			1-1/2						

Hub diameters may vary to suit bore sizes.
W = Winch sprocket with 5/16" x 5/32" key

Single Strand 80 Winch

RYLE P/N	LIST PRICE
80BS9H	76.80
80BS10H	84.00
80BS11H	93.00
80BS12H	103.00
80BS13H	112.60
80BS14H	124.20
80BS15H	132.00
80BS16H	142.00
80BS17H	157.00
80BS18H	178.40
80BS19H	186.00
80BS20H	204.40

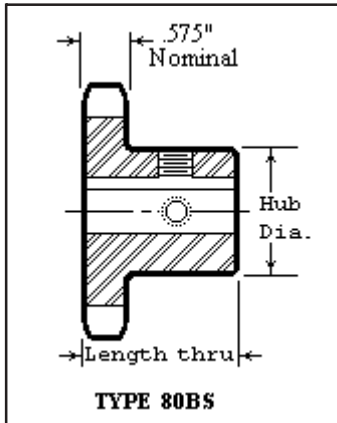

RYLE P/N	LIST PRICE	NO. TEETH	O.D. TEETH	LBS.	AVAILABLE BORE SIZES WITH (2) SETSCREWS	
80B10W	58.80	10	3.68	1.7	1-1/4	
80B11W	65.60	11	4.01	1.9	1-1/4	
80B12W	73.80	12	4.33	3.0	1-1/4	1-1/2
80B15W	95.60	15	5.30	4.7	1-1/4	1-1/2
80B18W	133.20	18	6.27	6.0	1-1/4	1-1/2
80B20W	150.40	20	6.91	6.5	1-1/4	1-1/2
80B21W	156.80	21	7.21	7.0	1-1/4	1-1/2

W = Winch sprocket with non-standard 5/16" keyway and (2) setscrews

Double Strand 80-2 Winch

RYLE P/N	LIST PRICE	NO. TEETH	O.D. TEETH	LBS.	AVAILABLE BORE SIZES WITH 2) SETSCREWS		
D80B12W	205.80	12	4.33	6.0	1-1/4	1-1/2 *	1-3/4 #
D80B14W	232.20	14	4.98	8.0		1-1/2 #	
D80B15W	244.00	15	5.30	10.0	1-1/4	1-1/2 *	1-3/4 # 2 #
D80B18W	298.00	18	6.27	14.0	1-1/4	1-1/2 *	1-3/4 # 2 #
D80B20W	356.80	20	6.91	17.0		1-1/2 *	1-3/4 # 2 #
D80B21W	390.20	21	7.21	19.0		1-1/2 #	2 #
D80B24W	477.40	24	8.20	26.0		1-1/2 *	1-3/4 # 2 #

W = Winch
(*) Indicates 5/16" & 3/8" key available (#) Indicates 3/8" key only
All Keyways In Line (KIL) with top of tooth
All have Induction Hardened Teeth and (2) setscrews

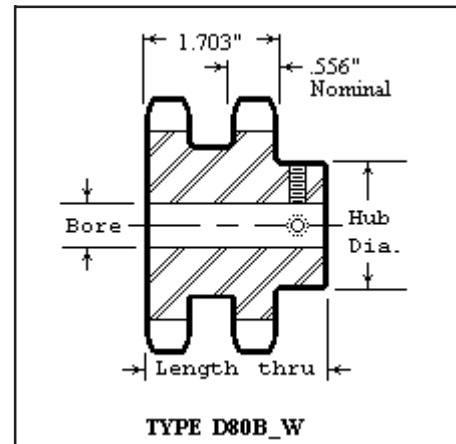



RYLE Manufacturing Company 1-800-433-0960

No. 80 1" Pitch

RYLE P/N	LIST PRICE	TYPE	O.D. TEETH	MAX BORE	L1	L2	C	Y	G	X	T	LBS.
80QD11SH	83.80	B	4.01	1-5/8	1-7/16	1-7/16	2-11/16	21/32	15/64	13/16	.575	.8
80QD12SH	92.00	B	4.33	1-5/8	1-7/16	1-7/16	2-11/16	21/32	15/64	13/16	.575	1.1
80QD13SDS	92.00	B	4.66	2	1-1/2	1-1/2	3-3/16	47/64	11/64	3/4	.575	1.3
80QD14SDS	98.80	B	4.98	2	1-1/2	1-1/2	3-3/16	47/64	11/64	3/4	.575	1.6
80QD15SK	108.60	B	5.30	2-5/8	2-1/8	2-1/8	3-7/8	1-19/64	21/32	1-1/4	.575	2.1
80QD16SK	113.40	B	5.63									3.2
80QD17SK	127.80	B	5.95									3.7
80QD18SK	141.20	B	6.21									4.2
80QD19SK	155.80	B	6.59	2-5/8	2-1/8	2-1/8	3-7/8	1-19/64	21/32	1-1/4	.575	5.0
80QD20SF	158.00	B	6.91	2-15/16	2-1/4	2-1/4	4-5/8	1-27/64	21/32	1-1/4	.575	5.6
80QD21SF	160.60	B	7.24									6.4
80QD22SF	167.60	B	7.56									6.8
80QD23SF	173.60	B	7.88									7.2
80QD24SF	177.20	B	8.20									7.6
80QD25SF	182.80	B	8.52									8.0
80QD26SF	203.40	B	8.84									8.5
80QD27SF	208.20	B	9.16									9.7
80QD28SF	218.00	B	9.48									10.9
80QD30SF	224.20	B	10.11									12.1
80QD32SF	235.80	B	10.75									12.5
80QD33SF	242.00	B	11.07									12.9
80QD34SF	249.40	B	11.39									13.2
80QD35SF	254.60	B	11.71									13.5
80QD36SF	261.40	B	12.03									14.0
80QD40SF	293.60	B	13.31									20.6
80QD42SF	312.00	B	13.94									23.5
80QD45SF	339.40	B	14.90									26.9
80QD48SF	386.60	B	15.86									29.8
80QD54SF	424.80	B	17.77									34.7
80QD60SF	516.80	B	19.68	2-15/16	2-1/4	2-1/4	4-5/8	1-27/64	21/32	1-1/4	.575	46.0
80QD70E	652.40	C	22.87	3-1/2	2-5/8	2-15/16	6	7/8	1-3/64	1-5/8	.575	67.0
80QD72E	717.40	C	23.50									75.0
80QD80E	809.00	C	26.05									80.0
80QD84E	913.20	C	27.33									98.0
80QD96E	1109.00	C	31.15									125.0
80QD112F	1327.40	C	36.24	3-1/2	2-5/8	2-15/16	6	7/8	1-3/64	1-5/8	.575	130.0

Harden per tooth\$ 1.78

QD Bushing dimensions and prices page 10

RYLE P/N	LIST PRICE
80QD11HSH	102.80
80QD12HSH	112.80
80QD13HSDS	114.20
80QD14HSDS	123.40
80QD15HSK	126.60
80QD16HSK	140.80
80QD17HSK	156.80
80QD18HSK	172.20
80QD19HSK	189.00
80QD20HSF	192.80
80QD21HSF	199.00
80QD22HSF	202.40
80QD23HSF	207.40
80QD24HSF	213.40
80QD25HSF	226.60
80QD26HSF	248.20
80QD27HSF	255.00
80QD28HSF	266.60
80QD30HSF	276.80

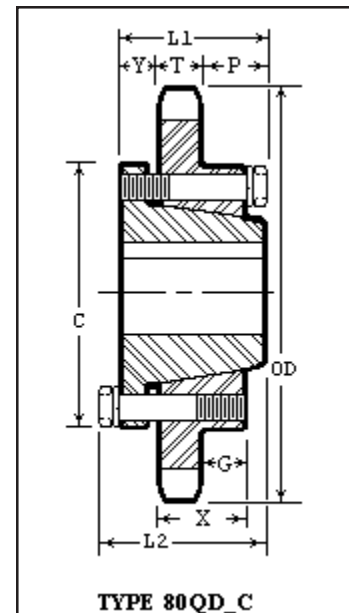
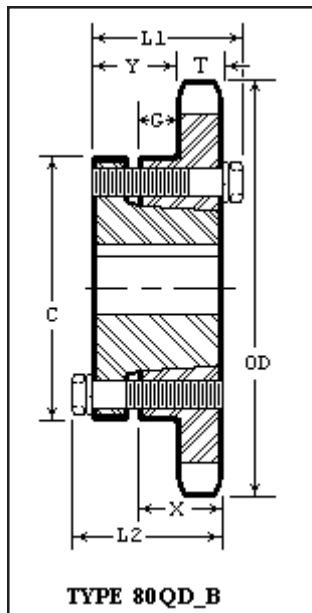



RYLE Manufacturing Company 1-800-433-0960

No. 80-2 Double Strand 1" Pitch

RYLE P/N	LIST PRICE	NO. TEETH	O.D. TEETH	STOCK BORE	MAX BORE	HUB DIA.	LTB	LBS.
D80B10H	158.60	10	3.68	1	1-1/2	2-9/16*	2-3/4	4.3
D80B11H	160.00	11	4.01	1	1-3/4	2-13/16*		5.4
D80B12H	169.60	12	4.33	1	1-7/8	3-1/8*		6.2
D80B13H	182.80	13	4.66	1	2-1/4	3-3/16	2-1/2	7.1
D80B14H	192.00	14	4.98	1	2-3/8	3-3/8		8.4
D80B15H	207.80	15	5.30	1	2-1/2	3-13/16		10.4
D80B16H	226.60	16	5.63	1	2-3/4	4-1/16	2-3/4	12.5
D80B17H	244.40	17	5.95	1	3	4-7/16		13.9
D80B18H	261.80	18	6.27	1	3-1/4	4-3/4		14.2
D80B19H	290.20	19	6.59	1	3-3/8	5		15.0
D80B20H	320.60	20	6.91	1				16.8
D80B21H	350.00	21	7.24	1				19.2
D80B22H	382.40	22	7.56	1				21.0
D80B23H	396.80	23	7.88	1				23.0
D80B24H	441.20	24	8.20	1	3-1/2	5-1/4		26.0
D80B25H	487.00	25	8.52	1			3	29.0
D80B26	511.00	26	8.84	1				33.0
D80B30	537.60	30	10.11	1	3-7/8	5-3/4		41.0
D80B32	566.60	32	10.75	1				45.0
D80B35	583.40	35	11.71	1				52.0
D80B36	600.40	36	12.03	1-1/4			3-1/8	55.0
D80B42	672.60	42	13.94					73.0
D80B45	754.60	45	14.90					80.0
D80C52	901.60	52	17.13	1-1/2	4-1/2	6-1/2	3-3/4	92.5
D80C60	1150.00	60	19.68					107.0
D80C68	1393.40	68	22.23				4	130.0
D80C76	1904.60	76	24.78					145.0
D80C95	2589.20	95	30.83				4-1/4	210.0

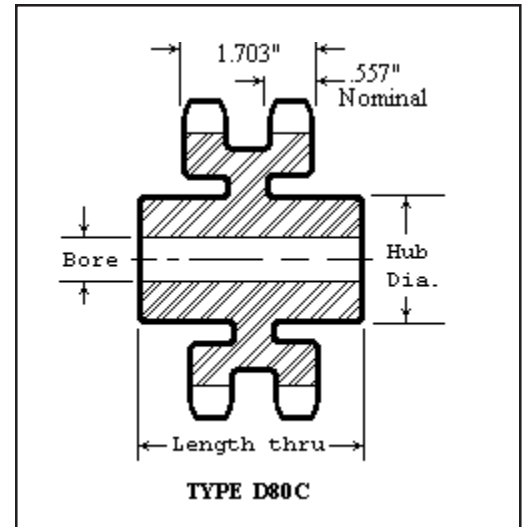
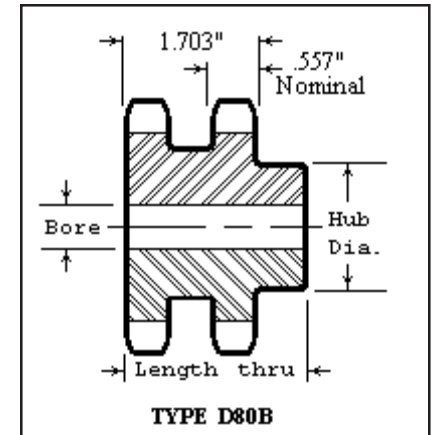

* Indicates hub diameter is grooved for chain clearance.
Note: 25 teeth or less already have Hardened Teeth.

Maximum bores will accommodate standard keyway and setscrew over key. Slightly larger bores may be possible with shallow keyway and/or setscrew at 90 degrees.
Multiple keyways must be priced at factory.

Rebore	\$49.00
Keyway	\$13.40
Setscrew (each)	\$13.40
Harden per tooth	\$ 1.78



RYLE Manufacturing Company 1-800-433-0960

No. 80-2 Double Strand 1" Pitch

No. 80-3 Triple Strand 1" Pitch

RYLE P/N	LIST PRICE	O.D. TEETH	MAX BORE	TYPE MOUNT	DIMENSIONS							LBS.				
					L1	L2	C	Y	P	G	V		X	T	W	
D80QD16HSK	336.00	5.63	2-5/8	(*)	2-1/8	2-1/8	3-7/8	1-19/64					1-1/4	.557	1.703	3.8
D80QD20HSF	386.00	6.92	2-15/16	(*)	2-1/4	2-1/4	4-5/8	1-27/64					1-1/4			7.5
D80QD36E	665.40	12.03	3-1/2	C1	2-5/8	2-15/16	6	51/64	1/8				1-5/8			47.0
D80QD42E	735.40	13.94		C1												56.0
D80QD45E	814.80	14.90		C1	2-5/8	2-15/16	6	51/64	1/8				1-5/8	.557	1.703	66.0
D80QD52E	986.00	17.13		C3	2-5/8	2-15/16	6	51/64	1/8		3/32		1-5/8	.557	1.703	70.0
D80QD60E	1270.60	19.68		C3							3/32					75.0
D80QD68E	1557.40	22.23		C3							3/32					83.0
D80QD76E	2148.00	24.78		C3	2-5/8	2-15/16	6	51/64	1/8		3/32		1-5/8	.557	1.703	100.0
D80QD95F	2832.80	30.83	3-15/16	C4	3-5/8	4	6-5/8	1	59/64	51/64			2-1/2	.557	1.703	140.0

Harden per tooth\$ 1.78

QD Bushing dimensions and prices page 10

(*) Drawing not illustrated

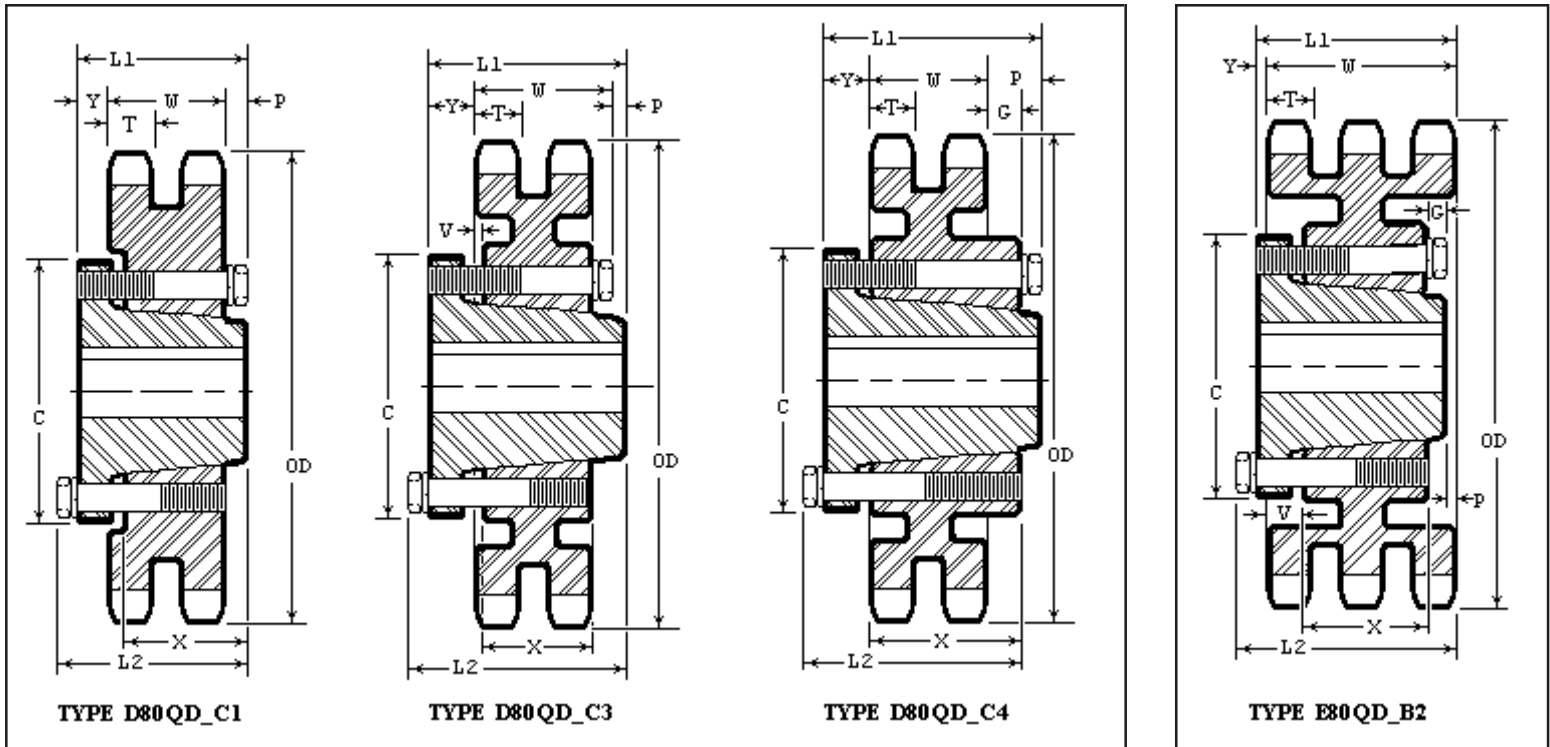

RYLE P/N	LIST PRICE	O.D. TEETH	MAX BORE	TYPE MOUNT	DIMENSIONS							LBS.				
					L1	L2	C	Y	P	G	V		X	T	W	
E80QD36E	1003.00	12.03	3-1/2	B2	3-7/64	3-27/64	6	1/4	31/64	1/8	5/8		1-5/8	.557	2.850	48.0
E80QD42E	1183.80	13.94		B2												56.0
E80QD45E	1333.20	14.90		B2												88.0
E80QD52E	1557.40	17.13	3-1/2	B2	3-7/64	3-27/64	6	1/4	31/64	1/8	5/8		1-5/8	.557	2.850	92.0
E80QD60F	1950.40	19.68	3-15/16	B2	3-43/64	4-3/64	6-5/8	13/16	3/64	1/8	3/16		2-1/2	.557	2.850	100.0
E80QD68F	2244.40	22.23		B2												130.0
E80QD76F	2743.60	24.78		B2												149.0
E80QD95F	3341.40	30.83	3-15/16	B2	3-43/64	4-3/64	6-5/8	13/16	3/64	1/8	3/16		2-1/2	.557	2.850	206.0

Harden per tooth\$ 1.78

QD Bushing dimensions and prices page 10



RYLE Manufacturing Company 1-800-433-0960

No. 80-3 Triple Strand 1" Pitch

RYLE P/N	LIST PRICE	NO. TEETH	O.D. TEETH	STOCK BORE	MAX BORE	HUB DIA.	LTB	LBS.
E80B10H	220.00	10	3.68	1	1-1/2	2-9/16*	3-7/8	5.0
E80B11H	223.80	11	4.01	1	1-3/4	2-13/16*		6.0
E80B12H	234.80	12	4.33	1	1-7/8	3-1/8*		7.9
E80B13H	245.80	13	4.66	1	2-1/4	3-3/16	3-5/8	9.1
E80B14H	263.20	14	4.98	1	2-3/8	3-3/8		10.3
E80B15H	282.60	15	5.30	1	2-1/2	3-13/16		12.2
E80B16H	325.60	16	5.63	1	2-3/4	4-1/16	3-7/8	15.0
E80B17H	345.80	17	5.95	1	3	4-7/16		17.8
E80B18H	379.00	18	6.27	1	3-1/4	4-3/4		19.1
E80B19H	418.60	19	6.59	1	3-3/8	5		21.6
E80B20H	438.80	20	6.91	1				25.0
E80B21H	460.00	21	7.24	1				28.0
E80B22H	507.20	22	7.56	1				32
E80B23H	542.40	23	7.88	1				37
E80B24H	614.80	24	8.20	1	3-1/2	5-1/4		43
E80B25H	689.60	25	8.52	1				49
E80B26	699.00	26	8.84	1				54
E80B30	781.00	30	10.11	1	4	6		69
E80B35	894.40	35	11.71	1				80
E80B36	918.60	36	12.03	1-1/4				85
E80C42	1072.80	42	13.94		4-1/2	6-1/2	4-1/2	100
E80C45	1205.40	45	14.90					110
E80C52	1393.40	52	17.13	1-1/2				115
E80C60	1786.40	60	19.68				4-3/4	122
E80C68	2083.00	68	22.23					130
E80C76	2514.40	76	24.78					150
E80C95	3025.60	95	30.83				5	215

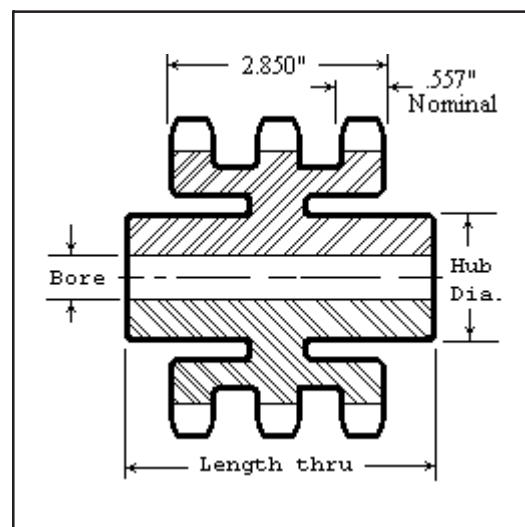
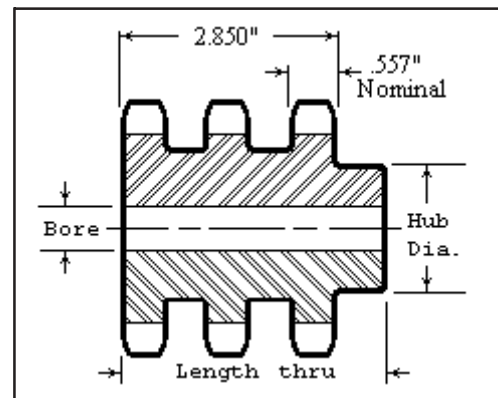

* Indicates hub diameter is grooved for chain clearance.

Note: 25 teeth or less already have Hardened Teeth.

Maximum bores will accommodate standard keyway and setscrew over key. Slightly larger bores may be possible with shallow keyway and/or setscrew at 90 degrees.

Multiple keyways must be priced at factory.

Rebore	\$49.00
Keyway	\$13.40
Setscrew (each)	\$13.40
Harden per tooth	\$ 1.78



RYLE Manufacturing Company 1-800-433-0960

No. 80-4 Quadruple Strand 1" Pitch

RYLE P/N	LIST PRICE	NO. TEETH	O.D. TEETH	STOCK BORE	MAX BORE	HUB DIA.	LTB	LBS.
F80B12H	546.00	12	4.33	1-1/4	1-7/8	2-3/4	5	9
F80B13H	568.00	13	4.66		2-1/4	3-3/16		11
F80B14H	646.00	14	4.98		2-3/8	3-1/2		14
F80B15H	696.00	15	5.30		2-1/2	3-13/16		17
F80B16H	746.00	16	5.63		2-3/4	4		20
F80B17H	818.00	17	5.95	1-1/2	3	4-3/8		23
F80B18H	878.00	18	6.27		3-1/4	4-3/4		26
F80B19H	934.00	19	6.59		3-3/8	5		30
F80B20H	1048.00	20	6.91					33
F80B21H	1136.00	21	7.24					36
F80B22H	1228.00	22	7.56					40
F80B23H	1292.00	23	7.88					44
F80B24H	1366.00	24	8.20					48
F80B25H	1464.00	25	8.52					52
F80B26H	1538.00	26	8.84					56
F80B30	1672.00	30	10.11		3-5/8	5-1/2	5-1/2	75
F80B35	1992.00	35	11.71					105
F80B40	2410.00	40	13.31					135
F80C45	3124.00	45	14.90	2				91
F80C52	3600.00	52	17.13					101
F80C60	4160.00	60	19.68		3-3/4	5-3/4	5-3/4	120
F80C68	4722.00	68	22.23					140
F80C76	5320.00	76	24.78		4	6	6	166
F80C95	6576.00	95	30.83					245

Note: 26 teeth or less already have Hardened Teeth.

Maximum bores will accommodate standard keyway and setscrew over key. Slightly larger bores may be possible with shallow keyway and/or setscrew at 90 degrees.

Multiple keyways must be priced at factory.

Rebore	\$49.00
Keyway	\$13.40
Setscrew (each)	\$13.40
Harden per tooth	\$ 1.78

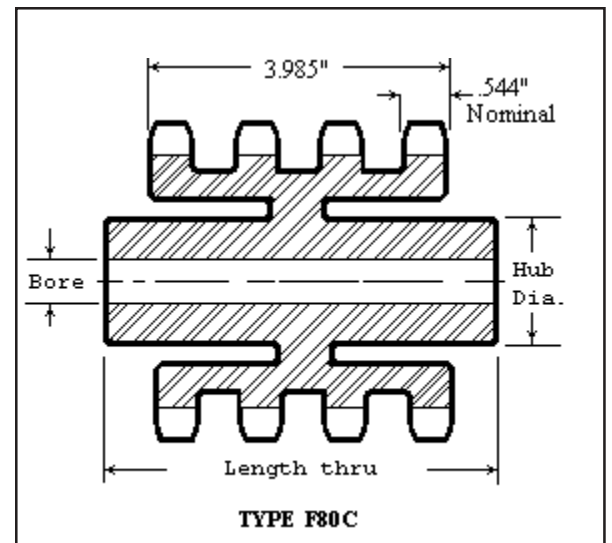
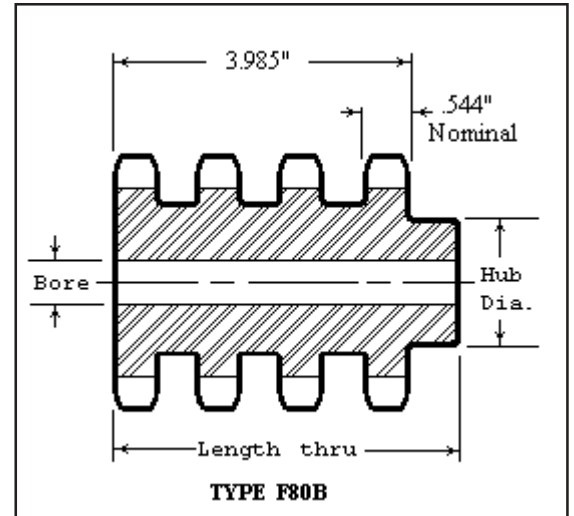

RYLE Manufacturing Company 1-800-433-0960

No. 100 1-1/4" Pitch

Type B & C

Type A

RYLE P/N	LIST PRICE	NO. TEETH	O.D. TEETH	STOCK BORE	MAX BORE	HUB DIA.	LTB	LBS	RYLE P/N	LIST PRICE	LBS.
100B8	65.20	7	3.35	1				2.2	100A7	53.40	1.2
100B9	88.20	8	3.77	1	1-1/4	2-7/16*	1-7/8	3.2	100A8	58.40	1.4
100B10	96.80	9	4.18	1	1-5/8	2-13/16*		4.1	100A9	62.80	2.0
100B11	112.40	10	4.60	1	1-7/8	3-1/4*		5.3	100A10	67.60	2.8
100B12	121.40	11	5.01	1	2-1/4	3-9/16*		6.5	100A11	68.40	3.5
100B13	130.60	12	5.42	1	2-1/2	4*		6.6	100A12	68.40	4.2
100B14	130.60	13	5.82	1	2-3/8	3-7/8	1-5/8	7.5	100A13	68.40	4.8
100B15	140.80	14	6.23	1-1/4	2-3/4	4-3/16		9.5	100A14	70.00	5.5
100B16	158.20	15	6.63		3	4-1/2	1-3/4	10.2	100A15	72.40	5.9
100B17	175.60	16	7.03					11.0	100A16	77.60	6.8
100B18	193.40	17	7.44					12.0	100A17	84.40	7.8
100B19	201.00	18	7.84					13.3	100A18	89.60	8.4
100B20	209.80	19	8.24				2	14.2	100A19	97.40	9.5
100B21	222.20	20	8.64					15.5	100A20	104.60	10.1
100B22	228.00	21	9.04					17.0	100A21	114.80	11.1
100B23	240.20	22	9.44					19.0	100A22	126.40	12.6
100B23	247.80	23	9.84						100A23	134.40	13.2
100B24	255.60	24	10.25					21.0	100A24	143.20	14.6
100B25	263.20	25	10.65					23.0	100A25	149.40	15.3
100B26	274.80	26	11.05		3-1/4	5		26.0	100A26	154.80	16.8
100B27	287.40	27	11.44					27.0	100A27	196.80	17.8
100B28	300.40	28	11.84					28.0	100A28	196.80	19.5
100B29	308.60	29	12.24					29.0	100A29	197.20	21.0
100B30	315.80	30	12.64					30.0	100A30	197.20	22.0
100B31		31	13.04						100A31	208.80	23.0
100B32	338.00	32	13.44					32	100A32	224.20	25
100B33		33	13.84						100A33	240.20	26
100B34		34	14.24						100A34	247.80	27
100B35	368.80	35	14.64				2-1/2	35	100A35	263.20	29
100B36	380.40	36	15.04					36	100A36	282.60	30
100B37		37	15.44						100A37	294.20	32
100B38		38	15.84						100A38	309.60	34
100B39	440.60	39	16.23					39	100A39	340.40	36
100B40	448.40	40	16.63					40	100A40	348.20	38
100B41		41	17.03						100A41	363.60	40
100B42	495.20	42	17.43					42	100A42	371.20	43
100B43		43	17.83	1-1/2					100A43	386.60	44
100B44		44	18.23						100A44	417.60	46
100B45	531.70	45	18.63					45	100A45	433.00	48
100B46		46	19.02						100A46	448.40	50
100B47		47	19.42						100A47	463.80	52
100B48	584.80	48	19.82		4	6		56	100A48	479.80	55
100B49		49	20.22						100A49	518.40	57
100B50		50	20.62						100A50	556.80	59
100B51		51	21.02						100A51	564.20	61
100B52		52	21.42						100A52	564.60	63
100B53		53	21.81						100A53	572.40	66
100C54	688.00	54	22.21				3-1/4	80	100A54	572.40	69
100C55		55	22.61						100A55	587.80	72
100C56		56	23.01						100A56	603.20	75
100C57		57	23.41						100A57	618.60	78
100C58		58	23.81						100A58	634.00	81
100C59		59	24.20						100A59	649.40	84
100C60	796.60	60	24.60					95	100A60	677.40	87
100C70	997.60	70	28.58		5-1/4	7	3-3/4	120	100A70	855.40	113
100C72	1074.80	72	29.38					128	100A72	959.00	121
100C76	1157.20	76	30.97					143	100A76	1060.80	133
100C80	1265.80	80	32.57					160	100A80	1198.60	155
100C84	1299.00	84	34.16					172	100A84	1245.00	170
100C90	1714.20	90	36.55					184	100A90	1584.40	193
100C96	1894.40	96	38.93				4-1/2	250	100A96	1762.80	223
100C112	2740.00	112	45.30					326	100A112	2160.00	298
100C120	3050.00	120	48.48					365	100A120	2450.00	340

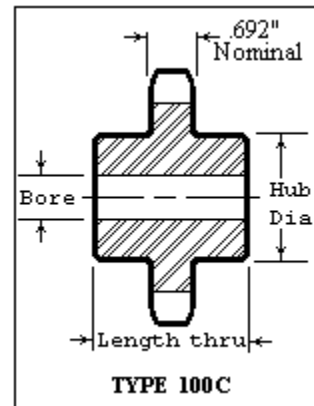
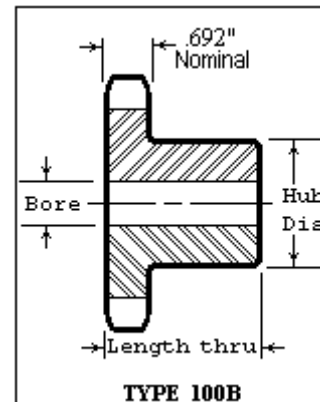
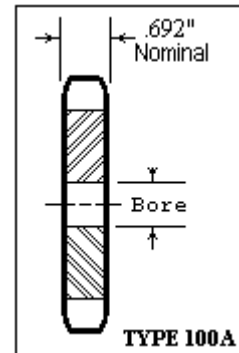

* Indicates hub diameter is grooved for chain clearance.

Maximum bores will accommodate standard keyway and setscrew over key. Slightly larger bores may be possible with shallow keyway and/or setscrew at 90 degrees. Multiple keyways must be priced at factory.

Split Type A plate \$ 3.78 per inch of sprocket diameter

Rebore \$49.00
Keyway \$13.40
Setscrew (each) \$13.40
Harden per tooth \$ 2.44

Drill Type A plate (4) holes = \$28.00
(6) holes = \$42.00
(8) holes = \$56.00



RYLE Manufacturing Company 1-800-433-0960

No. 100 1-1/4" Pitch

Type C

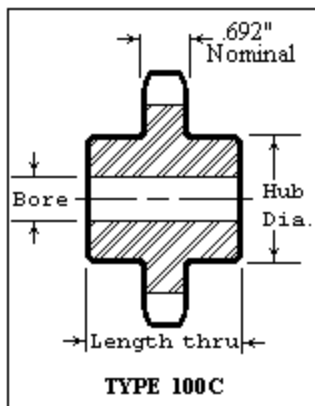

RYLE P/N	LIST PRICE	NO. TEETH	O.D. TEETH	STOCK BORE	MAX BORE	HUB DIA.	LTB	LBS.
100C10	242.00	10	4.60	1	1-7/8	3-9/32 *	2-7/8	6.1
100C11	258.00	11	5.01	1	2-1/4	3-9/16 *		7.1
100C12	284.00	12	5.42	1	2-1/2	3-37/64		8.4
100C13	323.80	13	5.82	1	2-3/8	3-15/16		10.0
100C14	347.00	14	6.23	1-1/4	2-3/4	4-5/16		12.2
100C15	370.00	15	6.63	1-1/4	3	4-5/8	2-7/8	13.0

* Indicates hub is grooved for chain clearance
Hub projection is centered.

Rebore	\$49.00
Keyway	\$13.40
Setscrew (each)	\$13.40
Harden per tooth	\$ 2.44

Double-Single

RYLE P/N	LIST PRICE	TEETH O.D.	STOCK BORE	MAX BORE	LTB	HUB DIA.	LBS
DS100A13	337.60	5.82	1	2-1/2	2-11/16	3-25/32	11.2
DS100A14	352.00	6.23	1-1/4	2-3/4		4-3/16	13.5
DS100A15	366.40	6.63		3-1/16		4-19/32	16.8
DS100A16	390.60	7.03		3-1/4		5	19.3
DS100A17	434.00	7.44		3-5/8		5-15/32	21.5
DS100A18	455.60	7.84		3-3/4		5-51/64	23.0
DS100A19	470.20	8.24		4-3/16		6-13/64	25.0
DS100A20	506.20	8.64		4-13/16		6-39/64	26.5
DS100A21	532.80	9.04	1-1/4	5-1/4	2-11/16	7	29.0

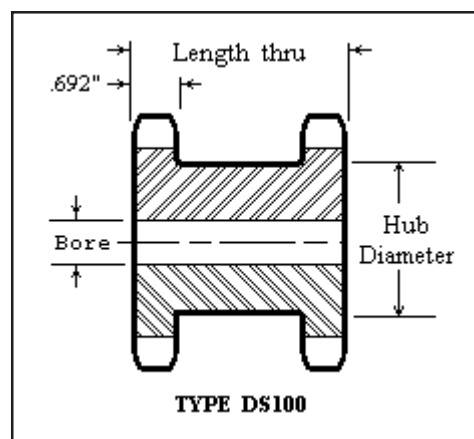



RYLE Manufacturing Company 1-800-433-0960

No. 100 1-1/4" Pitch

RYLE P/N	LIST PRICE	TYPE	O.D. TEETH	MAX BORE	L1	L2	C	Y	P	G	X	T	LBS.
100QD11SDS	141.80	B	5.01	2	1-1/2	1-1/2	3-3/16	5/8		1/16	3/4	.692	1.6
100QD12SDS	166.80	B	5.42	2	1-1/2	1-1/2	3-3/16	5/8		1/16	3/4		2.6
100QD13SK	178.40	B	5.81	2-5/8	2-1/8	2-1/8	3-7/8	1-13/64		9/16	1-1/4		3.0
100QD14SK	210.20	B	6.23	2-5/8	2-1/8	2-1/8	3-7/8	1-13/64		9/16	1-1/4		4.1
100QD15SF	224.20	B	6.63	2-15/16	2-1/4	2-1/4	4-5/8	1-19/64		9/16	1-1/4	.692	5.5
100QD16SF	229.00	B	7.03										6.1
100QD17SF	236.20	B	7.44	2-15/16	2-1/4	2-1/4	4-5/8	1-19/64		9/16	1-1/4	.692	7.0
100QD18E	244.80	B1	7.84	3-1/2	2-5/8	2-15/16	6	1-13/16	1/8	15/16	1-5/8	.692	7.6
100QD19E	245.80	B1	8.24										10.2
100QD20E	250.60	B1	8.64										10.6
100QD21E	250.60	B1	9.04										11.0
100QD22E	253.20	B1	9.44										11.6
100QD23E	255.60	B1	9.84										12.0
100QD24E	258.00	B1	10.25										13.1
100QD25E	265.60	B1	10.65										14.5
100QD26E	275.40	B1	11.05										18.1
100QD27E	289.40	B1	11.44										19.1
100QD28E	307.20	B1	11.84										20.2
100QD30E	330.80	B1	12.64										23.3
100QD32E	359.60	B1	13.44										26.5
100QD35E	419.00	B1	14.64										30.1
100QD36E	436.40	B1	15.04										35.0
100QD40E	533.20	B1	16.63										40.2
100QD42E	604.20	B1	17.43										46.7
100QD45E	629.20	B1	18.63										49.0
100QD48E	693.80	B1	19.82										52.0
100QD54E	816.80	B1	22.21										56.0
100QD60E	909.00	B1	24.60	3-1/2	2-5/8	2-15/16	6	1-13/16	1/8	15/16	1-5/8	.692	81.0
100QD70F	1298.00	C	28.58	3-15/16	3-5/8	4	6-5/8	1	1-15/16	1-13/16	2-1/2	.692	120
100QD72F	1376.20	C	29.38										125
100QD80F	1501.00	C	32.57										145
100QD84F	1656.80	C	34.16	3-15/16	3-5/8	4	6-5/8	1	1-15/16	1-13/16	2-1/2	.692	151

Harden per tooth\$ 2.44

QD Bushing dimensions and prices page 10

RYLE P/N	LIST PRICE
100QD11HSDS	168.80
100QD12HSDS	196.20
100QD13HSK	205.00
100QD14HSK	245.00
100QD15HSF	261.80
100QD16HSF	283.00
100QD17HSF	298.40
100QD018HE	303.80
100QD19HE	306.20
100QD20HE	308.60
100QD21HE	308.60
100QD22HE	311.00
100QD23HE	313.40
100QD24HE	315.80
100QD25HE	328.40
100QD26HE	340.00
100QD27HE	356.40
100QD28HE	376.60
100QD30HE	405.60

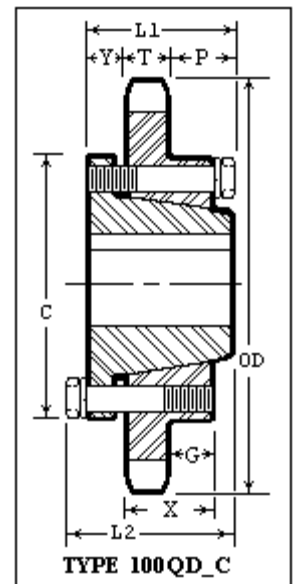
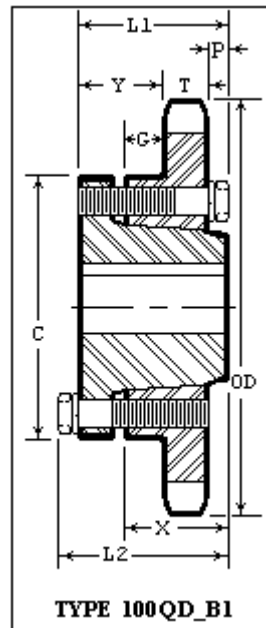
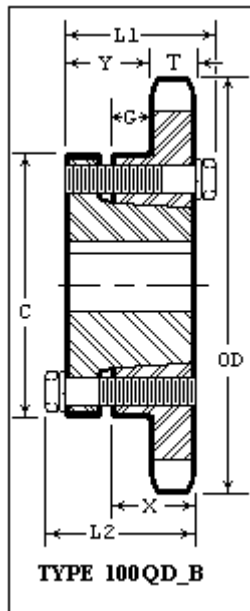



RYLE Manufacturing Company 1-800-433-0960

No. 100-2 Double Strand 1-1/4" Pitch

RYLE P/N	LIST PRICE	NO. TEETH	O.D. TEETH	STOCK BORE	MAX BORE	HUB DIA.	LTB	LBS
D100B9	216.60	9	4.18	1	1-7/8	2-13/16*	3-1/8	3.0
D100B10	232.00	10	4.60	1	2-1/8	3-1/4*		5.0
D100B11	253.60	11	5.01	1	2-1/4	3-9/16*		7.1
D100B12	276.80	12	5.42	1	2-1/2	4*		9.2
D100B13	303.20	13	5.82	1	2-1/2	3-7/8	2-7/8	11.2
D100B14	331.20	14	6.23	1	2-3/4	4-1/8		13.6
D100B15	363.60	15	6.63	1-1/4	3-1/8	4-5/8	3-1/8	16.1
D100B16	391.60	16	7.03		3-3/8	5		19.1
D100B17	421.00	17	7.44		3-1/2	5-1/4		22.0
D100B18	516.80	18	7.84					24.8
D100B19	581.40	19	8.24		3-3/4	5-1/2	3-3/8	27.5
D100B20	637.40	20	8.64					32.5
D100B21	693.20	21	9.04					37
D100B22	704.40	22	9.44					42
D100B23	731.00	23	9.84					47
D100B24	737.80	24	10.25			5-3/4		52
D100B25	814.80	25	10.65					57
D100B26	859.60	26	11.05	1-1/2	3-7/8		3-3/8	62
D100B28	967.40	28	11.84					65
D100B30	1075.20	30	12.64					80
D100C35	1210.20	35	14.64	1-1/2	4	6	4-1/4	68
D100C45	1579.20	45	18.63					125
D100C60	2333.80	60	24.60	2	5-3/8	7-1/2	5	162
D100C70	3447.60	70	28.58					187
D100C80	4158.80	80	32.57					216

* Indicates hub is grooved for chain clearance

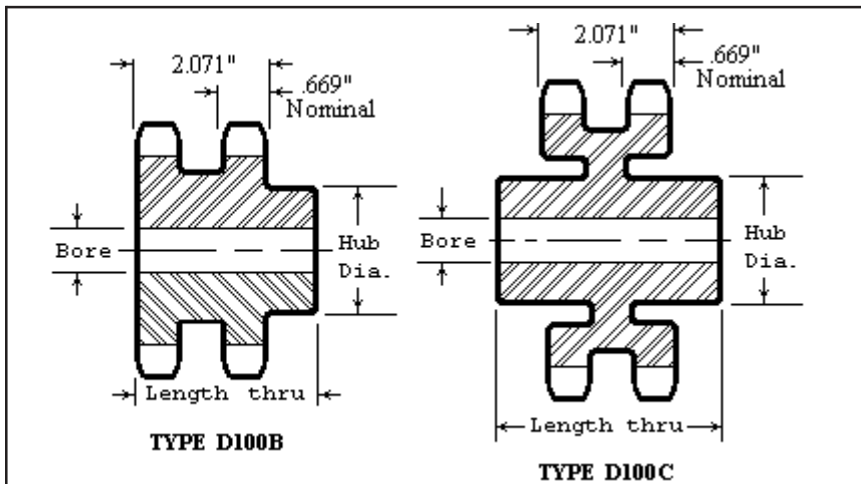
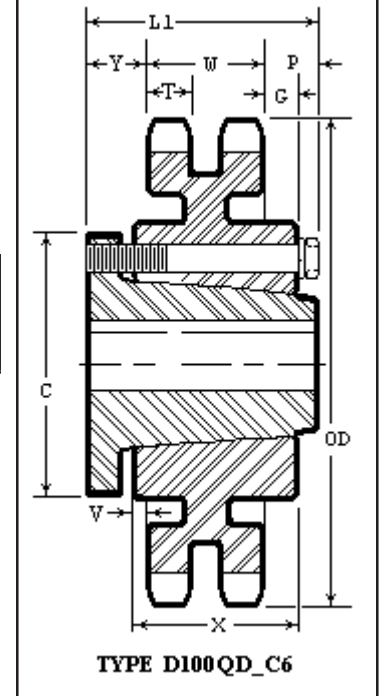
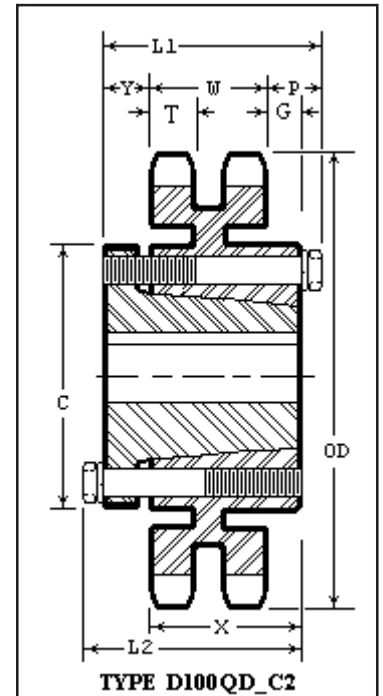

Rebore	\$49.00
Keyway	\$13.40
Setscrew (each)	\$13.40
Harden per tooth	\$ 2.44

RYLE P/N	LIST PRICE	O.D. TEETH	MAX BORE	TYPE MOUNT	DIMENSIONS											LBS.
					L1	L2	C	Y	P	G	V	X	T	W		
D100QD35F	1224.80	14.64	3-15/16	C2	3-5/8	4	6-5/8	1	35/64	27/64		2-1/2	.670	2.071	82	
D100QD45F	1733.40	18.63		C2	3-5/8	4	6-5/8	1	35/64	27/64		2-1/2	.670	2.071	108	
D100QD60J	2449.40	24.60	4-7/16	C6	3-1/2	5	7-1/4	1-7/32	1-13/64	1-3/32	1/32	3-3/16	.670	2.071	146	
D100QD70J	3818.80	28.58		C6											195	
D100QD80J	4537.20	32.57	4-7/16	C6	3-1/2	5	7-1/4	1-7/32	1-13/64	1-3/32	1/32	3-3/16	.670	2.071	237	



RYLE Manufacturing Company 1-800-433-0960

No. 100-3 Triple Strand 1-1/4" Pitch

RYLE P/N	LIST PRICE	NO. TEETH	O.D. TEETH	STOCK BORE	MAX BORE	HUB DIA.	LTB	LBS
E100B11	344.80	11	5.01	1	2-1/4	3-9/16 *	4-1/2	10.6
E100B12	368.40	12	5.42	1	2-1/2	4 *		13.6
E100B13	403.60	13	5.82	1	2-1/2	3-7/8		19.9
E100B14	456.20	14	6.23	1	2-3/4	4-1/8		21.0
E100B15	504.40	15	6.63	1-1/4	3-1/8	4-5/8		29.3
E100B16	535.20	16	7.03		3-3/8	5		27.6
E100B17	569.40	17	7.44		3-1/2	5-1/4		32.0
E100B18	781.00	18	7.84				4-3/4	36.3
E100B19	903.20	19	8.24		3-3/4	5-1/2		40.6
E100B20	1019.40	20	8.64					46.0
E100B21	1133.60	21	9.04					52
E100B22	1191.00	22	9.44					58
E100B23	1237.20	23	9.84					64
E100B24	1268.20	24	10.25			5-3/4		70
E100B25	1317.80	25	10.65					76
E100B26	1345.20	26	11.05	1-1/2	3-7/8			82
E100B28	1500.30	28	11.84					100
E100B30	1663.40	30	12.64					110
E100C35	1875.60	35	14.64	1-1/2	4	6	5	130
E100C45	2565.20	45	18.63		4-1/4	6-1/2		155
E100C60	3821.20	60	24.60	2	5-3/8	7-1/2		190
E100C70	4532.40	70	28.58					210
E100C80	5511.20	80	32.57					246

Rebore	\$49.00
Keyway	\$13.40
Setscrew (each)	\$13.40
Harden per tooth	\$ 2.44

* Indicates hub is grooved for chain clearance

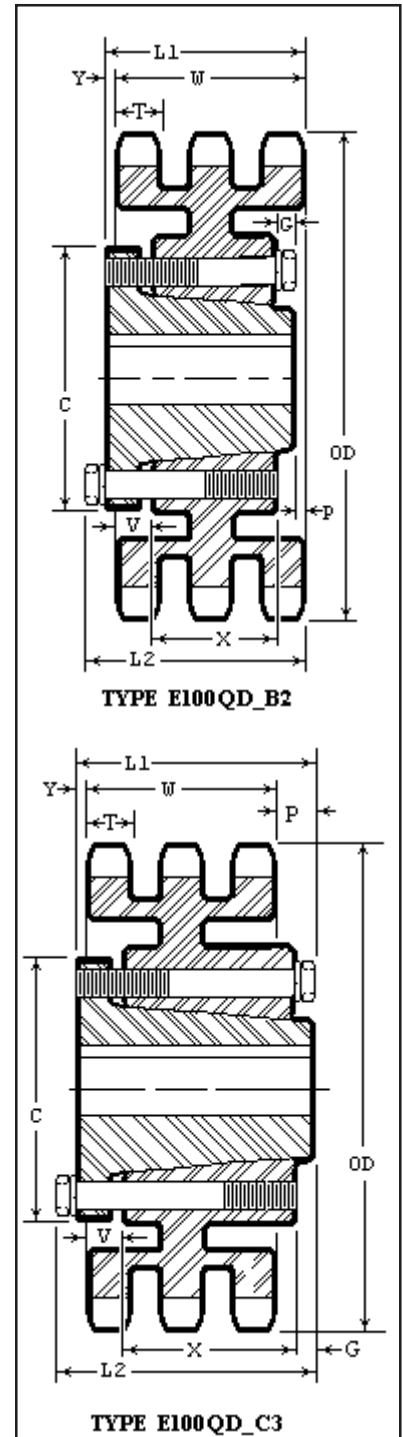
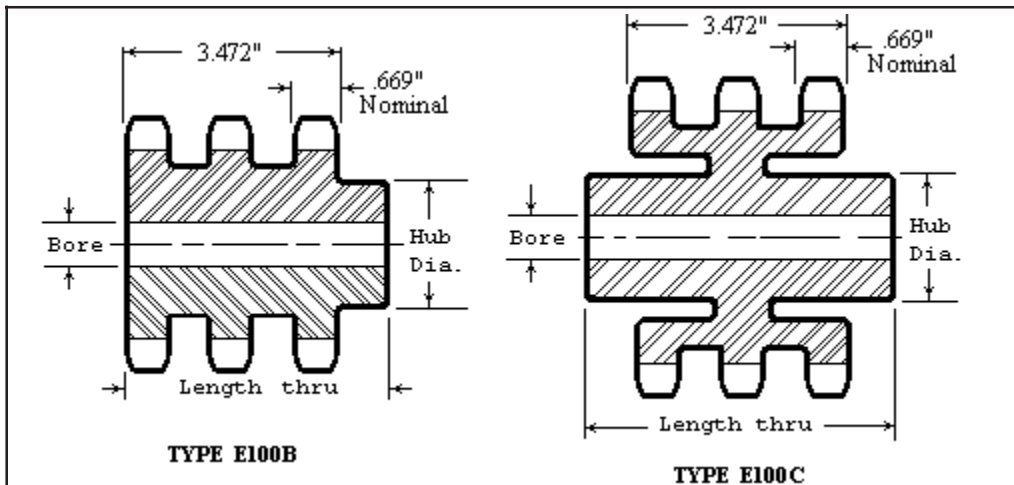

RYLE P/N	LIST PRICE	O.D. TEETH	MAX BORE	TYPE MOUNT	DIMENSIONS										LBS
					L1	L2	C	Y	P	G	V	X	T	W	
E100QD35F	1998.60	14.64	3-15/16	B2	3-3/64	4-23/64	6-5/8	1/2	23/64	1/8	1/2	2-1/2	.654	3.472	72
E100QD45F	2799.00	18.63		B2											140
E100QD60J	4166.60	24.60	4-7/16	C3	4-1/2	5	7-1/4	1/2	33/64	3/8	11/16	3-3/16	.654	3.472	173
E100QD70J	4973.60	28.58		C3											220
E100QD80J	6109.00	32.57	4-7/16	C3	4-1/2	5	7-1/4	1/2	33/64	3/8	11/16	3-3/16	.654	3.472	275

Harden per tooth\$ 2.44
 QD Bushing dimensions and prices page 8



RYLE Manufacturing Company 1-800-433-0960

No.100-4 Quadruple Strand 1-1/4" Pitch

RYLE P/N	LIST PRICE	NO. TEETH	O.D. TEETH	STOCK BORE	MAX BORE	HUB DIA.	LTB	LBS
F100B13	638.00	13	5.82	1-1/4	2-1/2	3-7/8	6	24
F100B14	670.00	14	6.23		2-3/4	4-1/8		27
F100B15	738.00	15	6.63		3-1/8	4-5/8		32
F100B16	820.00	16	7.03	1-1/2	3-3/8	5		38
F100B17	858.00	17	7.44		3-5/8	5-1/2		44
F100B18	1054.00	18	7.84					51
F100B19	1206.00	19	8.24					55
F100B20	1356.00	20	8.64			6-1/4		62
F100B21	1562.00	21	9.04					66
F100B22	1600.00	22	9.44					71
F100B23	1756.00	23	9.84					77
F100B24	1830.00	24	10.25	2	4		6-1/4	87
F100B25	2140.00	25	10.65					93
F100B26	2226.00	26	11.05					110
F100B28	2490.00	28	11.84					125
F100B30	2756.00	30	12.64					140
F100B32	2940.70	32	13.44					160
F100B35	3264.00	35	14.64					193
F100C45	3996.00	45	18.63		4-1/2	6-1/2		147
F100C60	5274.00	60	24.60					200
F100C70	6206.00	70	28.52		5-3/8	7-1/2	6-1/2	240
F100C80	7936.00	80	32.57					350

Rebore	\$49.00
Keyway	\$13.40
Setscrew (each)	\$13.40
Harden per tooth	\$ 2.44

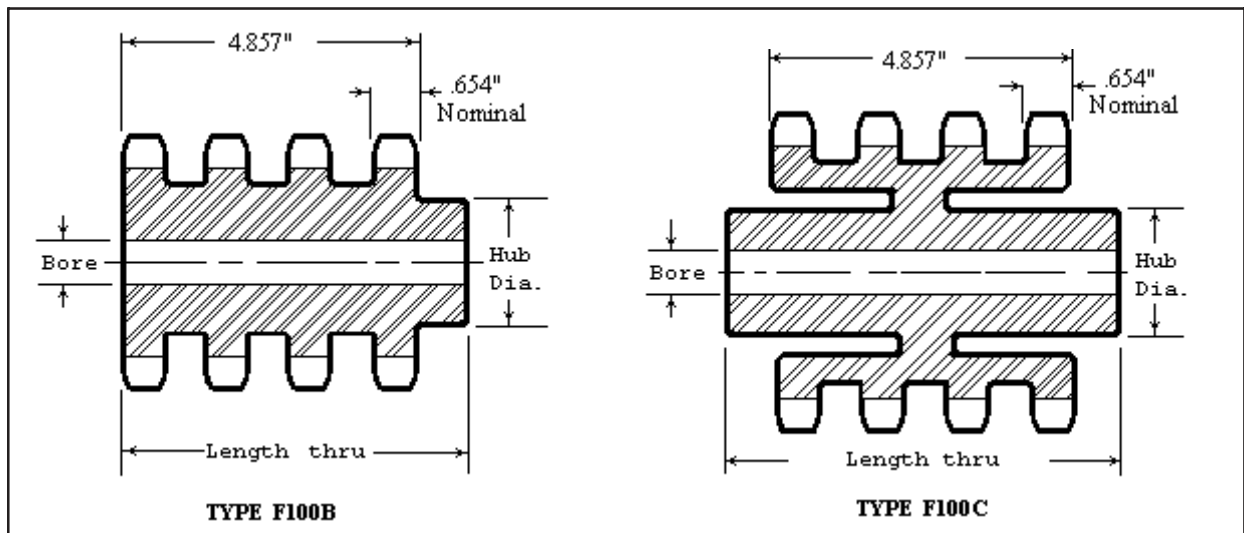

RYLE Manufacturing Company 1-800-433-0960

No. 120 1-1/2" Pitch

Type B & C

Type A

RYLE P/N	LIST PRICE	NO. TEETH	O.D. TEETH	STOCK BORE	MAX BORE	HUB DIA.	LTB	LBS.	RYLE P/N	LIST PRICE	LBS.
120B9	162.40	8	4.52	1-1/4					120A8	124.00	3.3
120B10	178.00	9	5.02		1-13/16	3-3/8 *	2-1/4	5.3	120A9	124.80	3.9
120B11	196.80	10	5.52		2-1/4	3-7/8 *		7.1	120A10	130.20	4.5
120B12	222.80	11	6.01		2-3/8	3-9/16	2-1/8	7.8	120A11	140.40	5.8
120B13	249.40	12	6.50		2-3/4	4-1/8		10.0	120A12	148.60	6.9
		13	6.99		3	4-9/16	2-1/4	12.8	120A13	157.20	8.2
120B14	274.80	14	7.47		3-1/4	4-3/4	2-3/8	14.2	120A14	166.40	9.1
120B15	301.80	15	7.96					17.8	120A15	178.00	10.0
120B16	324.00	16	8.44		3-1/2	5-1/4		18.5	120A16	185.60	11.5
120B17	346.60	17	8.92					20.8	120A17	197.20	13.1
120B18	366.40	18	9.41					22.0	120A18	208.80	14.6
120B19	385.20	19	9.89					25.0	120A19	220.40	16.2
120B20	400.60	20	10.37					26.5	120A20	232.00	18.0
120B21	422.40	21	10.85					29.0	120A21	244.00	20.5
120B22	446.60	22	11.33					31.5	120A22	259.40	23.0
120B23	470.20	23	11.81					34.0	120A23	274.80	25.6
120B24	485.60	24	12.29					36.2	120A24	290.20	27.7
120B25	501.00	25	12.77					38.3	120A25	300.80	29.8
120B26	510.60	26	13.25	1-1/2	4	6	2-1/2	46.0	120A26	321.20	32.0
120B27		27	13.73						120A27	363.60	35.0
120B28	549.20	28	14.21					52.0	120A28	371.20	38.0
120B29		29	14.69					54.0	120A29	374.10	39.5
120B30	587.80	30	15.17					56.5	120A30	386.60	42.5
120B31		31	15.65					59.5	120A31	463.80	46.5
120B32	626.40	32	16.13					61.0	120A32	463.80	48.5
120B33		33	16.61						120A33	479.80	50.0
120B34		34	17.09						120A34	495.20	52.0
120B35	664.80	35	17.57					70.0	120A35	495.20	55.0
120B36	688.00	36	18.05					74.0	120A36	514.40	58.5
120C40	773.40	40	19.96				3	92.0	120A40	599.40	76.0
120C42	850.60	42	20.92					100	120A42	696.20	83.5
120C45	893.00	45	22.35					107	120A45	727.20	96.5
120C48	966.80	48	23.79				4	120	120A48	773.40	110
120C54	1098.00	54	26.65					137	120A54	1005.40	127
120C60	1367.00	60	29.52		5-1/4	7		175	120A60	1205.40	165
120C70	1743.00	70	34.30	2	5-3/8	7-1/2	4-1/2	235	120A70	1639.40	225
120C80	2124.00	80	39.08					300	120A80	2037.20	290
120C90		90	43.85						120A90	2847.20	360

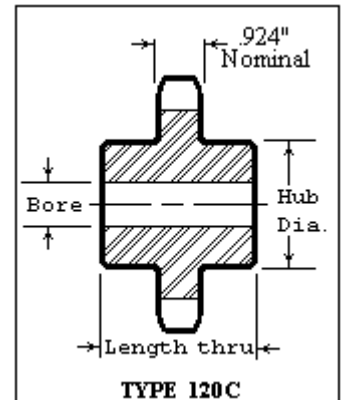
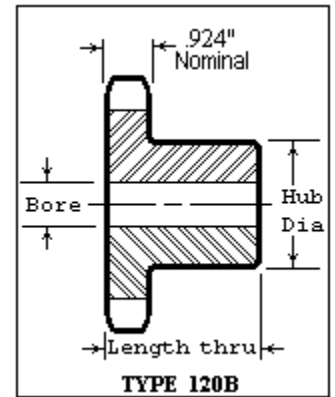
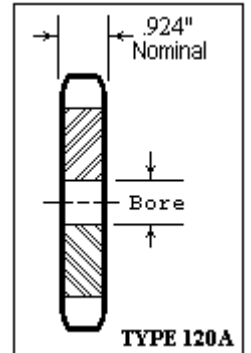

* Indicates hub diameter is grooved for chain clearance.

Maximum bores will accommodate standard keyway and setscrew over key. Slightly larger bores may be possible with shallow keyway and/or setscrew at 90 degrees. Multiple keyways must be priced at factory.

Split Type A plate	\$ 4.08
per inch of sprocket diameter	
Rebore	\$49.00
Keyway	\$13.40
Setscrew (each)	\$13.40
Harden per tooth	\$ 3.06
Drill Type A plate	(4) holes = \$28.00
	(6) holes = \$42.00
	(8) holes = \$56.00

RYLE P/N	LIST PRICE	NO. TEETH	O.D. TEETH	STOCK BORE	MAX BORE	HUB DIA	LTB	LBS
120C11	412.00	11	6.01	1-1/4	2-3/8	3-9/16	3-3/8	12.5
120C12	462.00	12	6.50		2-3/4	4-1/4		14.8
120C13	534.00	13	6.99		3	4-5/8		17.2
120C14	540.00	14	7.47		3-1/4	5-1/8		19.5

Hub projection is centered



RYLE Manufacturing Company 1-800-433-0960

No. 120 1-1/2" Pitch

RYLE P/N	LIST PRICE	TYPE MOUNT	O.D. TEETH	MAX BORE	DIMENSIONS								LBS	
					L1	L2	C	Y	P	G	X	T		
120QD12SF	265.20	B	6.50	2-15/16	2-1/4	2-1/4	4-5/8	1-5/64			21/64	1-1/4	.924	5.1
120QD13SF	302.80	B	6.99											5.8
120QD14SF	333.20	B	7.47											7.0
120QD15SF	370.40	B	7.96	2-15/16	2-1/4	2-1/4	4-5/8	1-5/64			21/64	1-1/4	.924	9.0
120QD16E	373.80	B1	8.44	3-1/2	2-5/8	2-15/16	6	1-9/16	1/8		45/64	1-5/8	.924	11.1
120QD17E	383.40	B1	8.92											12.3
120QD18E	389.20	B1	9.41											14.6
120QD19E	419.00	B1	9.89											16.0
120QD20E	453.20	B1	10.37											17.5
120QD21E	472.60	B1	10.85											19.3
120QD22E	486.00	B1	11.33											21.4
120QD23E	500.00	B1	11.81											23.6
120QD24E	508.60	B1	12.29											25.9
120QD25E	538.60	B1	12.77											27.0
120QD26E	576.20	B1	13.25											29.8
120QD28E	623.40	B1	14.21											36.0
120QD30E	673.20	B1	15.17	3-1/2	2-5/8	2-15/16	6	1-9/16	1/8		45/64	1-5/8	.924	40.0
120QD32F	699.20	C	16.13	3-15/16	3-5/8	4	6-5/8	1	1-11/16	1-37/64	2-1/2	.924	50.0	
120QD35F	736.20	C	17.57											60.0
120QD36F	759.00	C	18.05											70.0
120QD40F	806.60	C	19.96											80
120QD42F	860.20	C	20.92											95
120QD45F	943.20	C	22.35											100
120QD48F	1113.40	C	23.79											110
120QD54F	1266.60	C	26.65	3-15/16	3-5/8	4	6-5/8	1	1-11/16	1-37/64	2-1/2	.924	120	
120QD60J	1434.40	C	29.52	4-7/16	4-1/2	5	7-1/4	1-3/16	2-5/16	2-17/64	3-3/16	.924	135	
120QD70J	1790.80	C	34.30											183
120QD80J	2250.40	C	39.08	4-7/16	4-1/2	5	7-1/4	1-3/16	2-5/16	2-17/64	3-3/16	.924	250	

Harden per tooth\$ 3.06

QD Bushing dimensions and prices page 10

RYLE P/N	LIST PRICE
120QD12HSF	302.80
120QD13HSF	343.40
120QD14HSF	376.60
120QD15HSF	417.60
120QD16HE	424.40
120QD17HE	429.20
120QD18HE	444.40
120QD19HE	478.20
120QD20HE	498.60
120QD21HE	522.20
120QD22HE	555.00
120QD23HE	572.40
120QD24HE	583.80
120QD25HE	616.60
120QD26HE	657.20
120QD28HE	711.20
120QD30HE	766.60

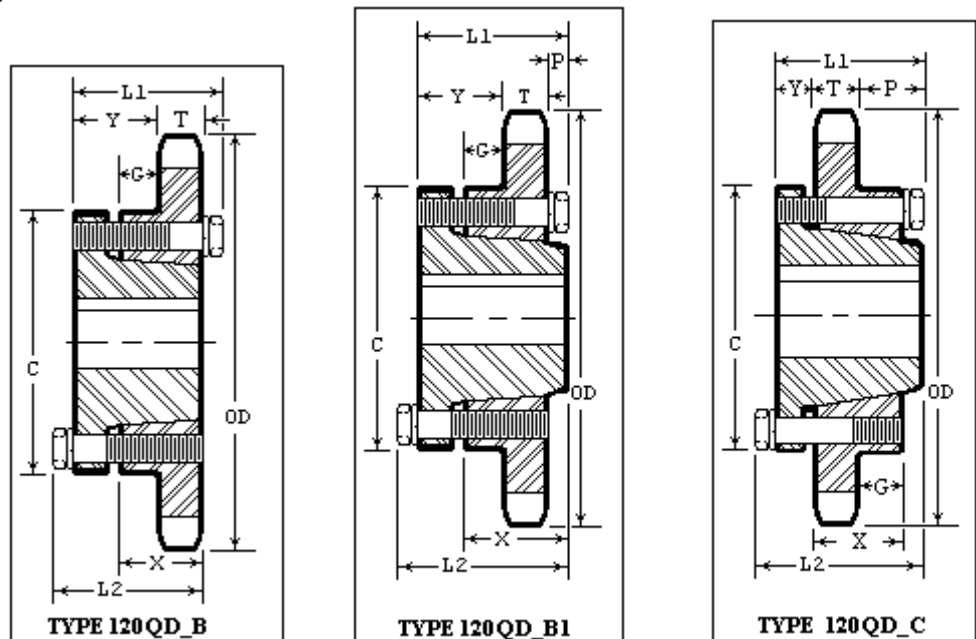



RYLE Manufacturing Company 1-800-433-0960

No. 120 Double Strand 1-1/2" Pitch

RYLE P/N	LIST PRICE	NO. TEETH	O.D. TEETH	STOCK BORE	MAX BORE	HUB DIA.	LTB	LBS
D120B11	603.20	11	6.01	1-1/2	2-3/8	3-9/16	3-3/4	20
D120B12	635.20	12	6.50		2-3/4	4-1/16		23
D120B13	680.40	13	6.99		3	4-1/2		27
D120B14	727.20	14	7.47		3-1/4	5		32
D120B15	758.00	15	7.96		3-1/2	5-1/4		38
D120B16	788.80	16	8.44					42
D120B17	835.20	17	8.92					46
D120B18	912.20	18	9.41					50
D120B19	974.40	19	9.89					55
D120B20	1020.80	20	10.37					60
D120B21	1082.40	21	10.85					66
D120B22	1160.00	22	11.33		3-3/4	5-3/4	4	75
D120B23	1299.00	23	11.81		4-1/4	6-1/4		81
D120B24	1329.80	24	12.29					85
D120B25	1392.00	25	12.77					90
D120B26	1407.40	26	13.25					95
D120B28	1500.00	28	14.21					104
D120B30	1540.60	30	15.17					115
D120B32	1760.00	32	16.13					125
D120C35	1793.60	35	17.57	2	5-3/8	7-1/2	6	147
D120C36	2060.80	36	18.05					150
D120C40	2420.60	40	19.96					160
D120C45	1952.80	45	22.35					190
D120C54	3260.00	54	26.65					210
D120C60	3358.20	60	29.52		6-1/2	9-1/2	6-1/4	300
D120C70	5820.00	70	34.30					320
D120C80	6624.90	80	39.08					360

Rebore \$49.00
 Keyway \$13.40
 Setscrew (each) \$13.40
 Harden per tooth \$ 3.06

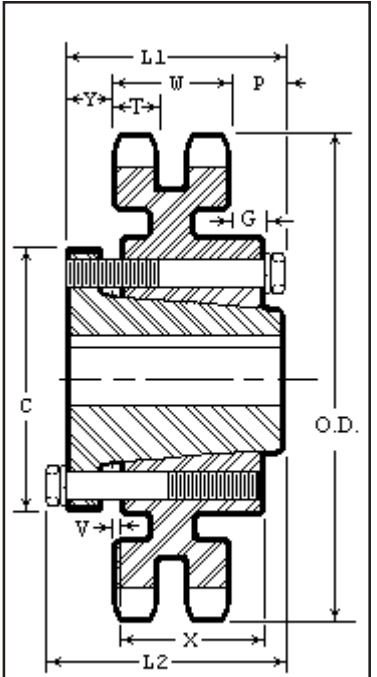

TYPE D120QD_C5

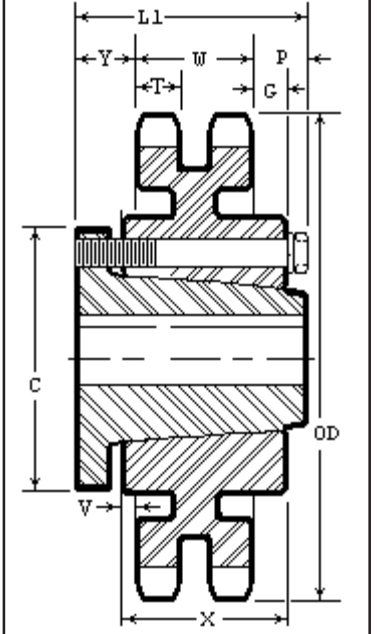

TYPE D120QD_C6

Maximum bores will accommodate standard keyway and setscrew over key. Slightly larger bores may be possible with shallow keyway and/or setscrew at 90 degrees. Multiple keyways must be priced at factory.

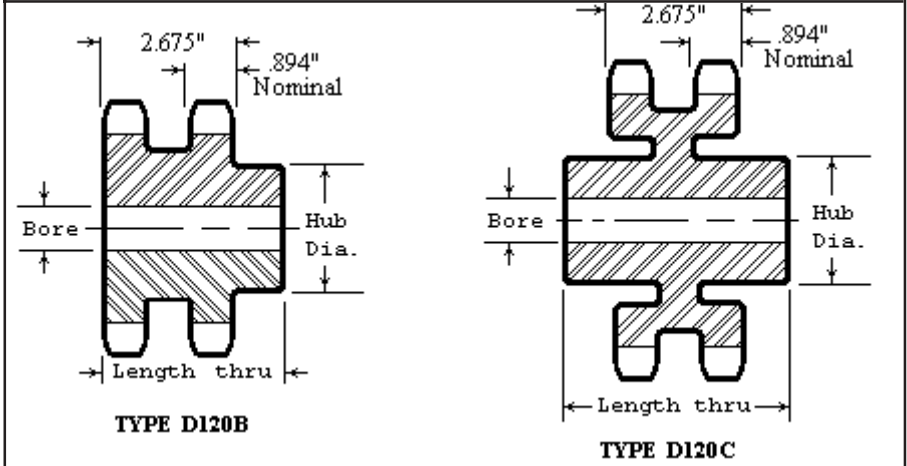

TYPE D120B

TYPE D120C

RYLE P/N	LIST PRICE	O.D. TEETH	MAX BORE	TYPE MOUNT	L1	L2	DIMENSIONS							LBS.	
							C	Y	P	G	V	X	T	W	
D120QD30J	1670.60	15.17	4-7/16	C5	4-1/2	5	7-1/4	1-1/32	25/32	21/32	5/32	3-3/16	.894	2.675	54
D120QD35J	1878.00	17.57		C5											91
D120QD45J	2051.60	22.35	4-7/16	C5	4-1/2	5	7-1/4	1-1/32	25/32	21/32	5/32	3-3/16	.894	2.675	162
D120QD60M	3524.60	29.52	5-1/2	C6	6-3/4	6-3/4	9	2-9/32	1-25/32	1-21/32	27/32	5-3/16	.894	2.675	255

Harden per tooth\$ 3.06
 QD Bushing dimensions and prices page 10



RYLE Manufacturing Company 1-800-433-0960

No. 120 Triple Strand 1-1/2" Pitch

RYLE P/N	LIST PRICE	NO. TEETH	O.D. TEETH	STOCK BORE	MAX BORE	HUB DIA.	LTB	LBS.
E120B11	904.80	11	6.01	1-1/2	2-3/8	3-3/4	5-1/2	24
E120B12	951.00	12	6.50		2-3/4	4-1/4		29
E120B13	1020.60	13	6.99		3	4-3/4	5-3/4	31
E120B14	1090.80	14	7.47		3-1/4	5		38
E120B15	1137.00	15	7.96		3-1/2	5-1/2		45
E120B16	1183.20	16	8.44			6		52
E120B17	1252.80	17	8.92				5-7/8	66
E120B18	1468.30	18	9.41					70
E120B19	1661.60	19	9.89					78
E120B20	1831.20	20	10.37					86
E120B21	1923.60	21	10.85					95
E120B22	2020.40	22	11.33		3-3/4			102
E120B23	2116.50	23	11.81		4-3/4	6-1/2		111
E120B24	2210.10	24	12.29					120
E120B25	2300.70	25	12.77					132
E120B26	2390.00	26	13.25					140
E120B28	2510.00	28	14.21					165
E120B30	2760.50	30	15.17					191
E120B32	2945.90	32	16.13					218
E120C35	4190.40	35	17.57	2	5-3/8	7-1/2	6-1/8	140
E120C36	4367.30	36	18.05					142
E120C40	5403.80	40	19.96					158
E120C45	5089.20	45	22.35					175
E120C54	5835.60	54	26.65				6-3/8	230
E120C60	6437.30	60	29.52		6-1/2	9-1/2		300

Maximum bores will accommodate standard keyway and setscrew over key. Slightly larger bores may be possible with shallow keyway and/or setscrew at 90 degrees. Multiple keyways must be priced at factory.

Rebore	\$49.00
Keyway	\$13.40
Setscrew (each)	\$13.40
Harden per tooth	\$ 3.06

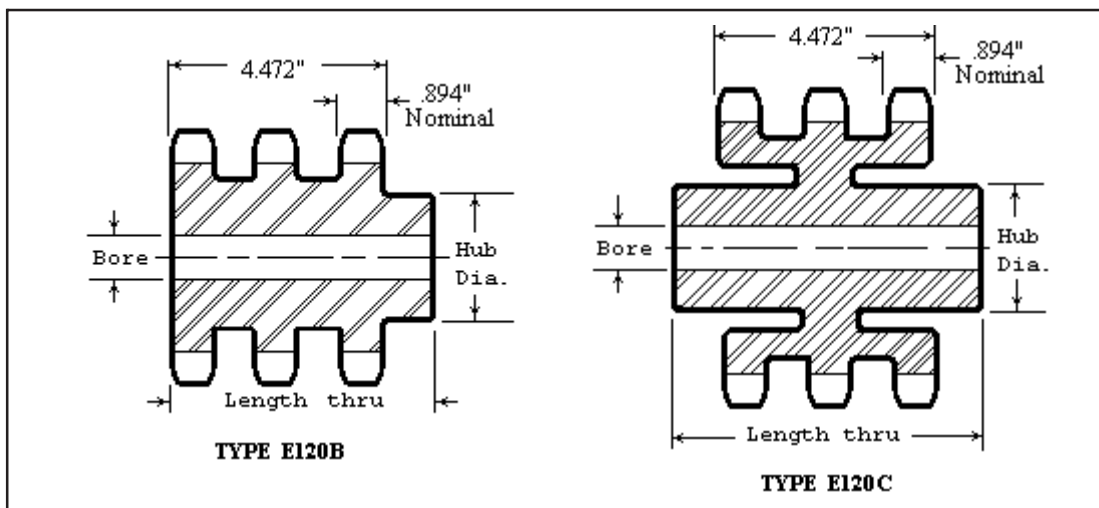



RYLE Manufacturing Company 1-800-433-0960

No. 120 Quadruple Strand 1-1/2" Pitch

RYLE P/N	LIST PRICE	NO. TEETH	O.D. TEETH	STOCK BORE	MAX BORE	HUB DIA.	LTB	LBS.
F120B12	1450.00	12	6.50	1-1/2	2-3/4	4-1/4	7-3/8	29
F120B13	1565.10	13	6.99		3	4-3/4		31
F120B14	1688.90	14	7.47		3-1/4	5		38
F120B15	1852.20	15	7.96		3-3/4	5-1/2		44
F120B16	1978.60	16	8.44					52
F120B17	2018.80	17	8.92				7-3/4	66
F120B18	2203.20	18	9.41					70
F120B19	2354.00	19	9.89					78
F120B20	2420.20	20	10.37					86
F120B21	2480.70	21	10.85					95
F120B22	2510.80	22	11.33					102
F120B23	2520.40	23	11.81		4-3/4	6-1/2		111
F120B24	2530.00	24	12.29					120
F120B25	2630.00	25	12.77					132
F120B26	2760.00	26	13.25					140
F120B28	2950.00	28	14.21	2				165
F120B30	3160.00	30	15.17					191
F120B32	3896.80	32	16.13					218
F120C35	6195.00	35	17.57		5-3/8	7-1/2	8	140
F120C36	6486.40	36	18.05					142
F120C40	7010.20	40	19.96					158
F120C45	7881.20	45	22.35					175
F120C54	8797.60	54	26.65				8-1/4	230
F120C60	10140.60	60	29.52		6-1/2	9-1/2		300

Maximum bores will accommodate standard keyway and setscrew over key. Slightly larger bores may be possible with shallow keyway and/or setscrew at 90 degrees.
Multiple keyways must be priced at factory.

Rebore	\$49.00
Keyway	\$13.40
Setscrew (each)	\$13.40
Harden per tooth	\$ 3.06

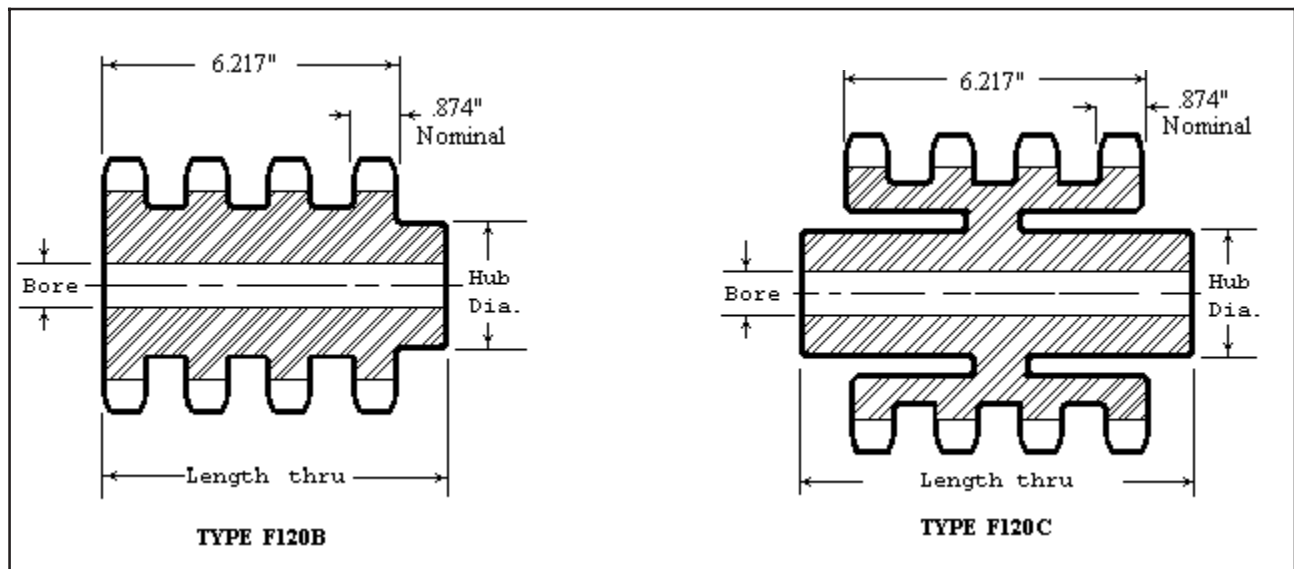



RYLE Manufacturing Company 1-800-433-0960

No. 140 1-3/4" Pitch

Type B & C

Type A

RYLE P/N	LIST PRICE	NO. TEETH	O.D. TEETH	STOCK BORE	MAX BORE	HUB DIA.	LTB	LBS.	RYLE P/N	LIST PRICE	LBS.
140B10	275.40	10	6.43	1-1/2	2-3/8	3-27/32	2-1/4	11	140A10	156.00	6
140B11	298.00	11	7.01		2-3/4	4-1/4		13	140A11	160.00	8
140B12	330.40	12	7.58		3	4-1/2		15	140A12	170.20	9
140B13	363.60	13	8.15		3-3/4	5-1/2	2-3/8	16	140A13	184.20	10
140B14	395.80	14	8.72		4	6		19	140A14	199.60	12
140B15	427.60	15	9.28		4-1/4	6	2-1/2	22	140A15	213.60	13
140B16	444.60	16	9.85		4-1/2	6-1/2		25	140A16	228.00	15
140B17	463.80	17	10.41					28	140A17	244.00	18
140B18	479.80	18	10.98					30	140A18	259.40	20
140B19	510.60	19	11.54					32	140A19	278.60	22
140B20	533.80	20	12.10					34	140A20	294.20	25
140B21	545.80	21	12.66					37	140A21	312.40	28
140B22	559.40	22	13.22					40	140A22	336.60	30
140B23	573.80	23	13.78					44	140A23	359.60	33
140B24	590.60	24	14.34					47	140A24	382.80	36
140B25	607.60	25	14.90					51	140A25	393.00	39
140B26	624.40	26	15.46				3	60	140A26	413.20	42
140B27	643.80	27	16.02					63	140A27	448.40	45
140B28	657.20	28	16.58					67	140A28	479.80	49
140B30	680.40	30	17.70					73	140A30	505.80	55
140B31		31	18.26						140A31	556.80	59
140B32	711.80	32	18.82					80	140A32	603.20	62
140B33		33	19.37						140A33	622.00	66
140B34		34	19.93						140A34	630.00	78
140C35	839.00	35	20.49		5-1/4	7	4	84	140A35	631.20	81
140C36	954.40	36	21.05					110	140A36	657.20	84
140C40	1074.80	40	23.29					135	140A40	781.00	105
140C42		42	24.40						140A42	820.00	110
140C45	1121.00	45	26.08	2				170	140A45	974.40	130
140C48	1412.80	48	27.75					180	140A48	1113.80	150
140C50		50	28.86						140A50	1209.40	164
140C54	1706.80	54	31.10					225	140A54	1400.60	195
140C60	1834.60	60	34.44				5	267	140A60	1699.60	232
140C68		68	38.90						140A66	1978.00	298
140C70	2439.80	70	40.20		5-1/2	7-1/2		350	140A70	2213.20	315
140C80	3016.00	80	45.59					450	140A80	2753.20	415
140C84	3915.00	84	47.82					485	140A84	3267.00	431
140C96	4984.90	96	54.50					630	140A96	4178.00	560

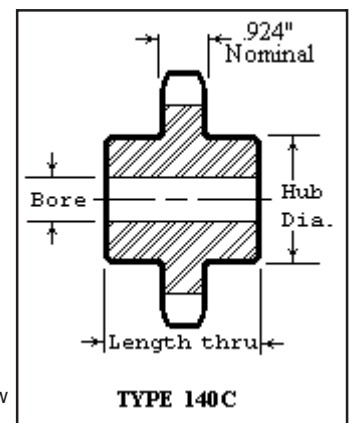
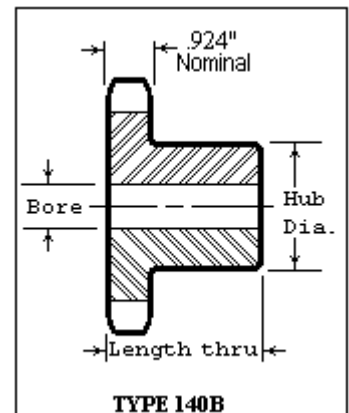
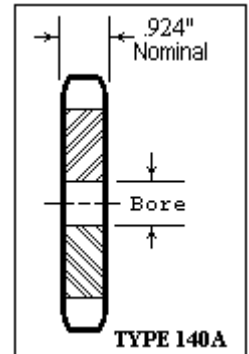

Maximum bores will accommodate standard keyway and setscrew over key. Slightly larger bore may be possible with shallow keyway and/or setscrew at 90 degrees. Multiple keyways must be priced at factory.

Split Type A plate	\$ 4.08
per inch of sprocket diameter	
Rebore	\$49.00
Keyway	\$13.40
Setscrew (each)	\$13.40
Harden per tooth	\$ 3.34
Drill Type A plate	(4) holes = \$28.00
	(6) holes = \$42.00
	(8) holes = \$56.00

RYLE Manufacturing Company 1-800-433-0960

No. 140 1-3/4" Pitch

RYLE P/N	LIST PRICE	TYPE MOUNT	O.D. TEETH	MAX BORE	L1	L2	C	Y	P	G	X	T	V	LBS
140QD11SF	321.60	B	7.01	2-15/16	2-1/4	2-1/4	4-5/8	1-5/64		21/64	1-1/4	.924		7
140QD12SF	384.80	B	7.58											8
140QD13SF	403.60	B	8.15	2-15/16	2-1/4	2-1/4	4-5/8	1-5/64		21/64	1-1/4	.924		9
140QD14E	419.00	B1	8.72	3-1/2	2-5/8	2-15/16	6	1-9/16	1/8	45/64	1-5/8	.924		13
140QD15E	441.80	B1	9.28											14
140QD16E	471.60	B1	9.85											16
140QD17E	494.20	B1	10.41											18
140QD18E	516.40	B1	10.98											20
140QD19E	545.40	B1	11.54											22
140QD20E	607.60	B1	12.10											25
140QD21E	617.20	B1	12.66											27
140QD22E	641.40	B1	13.22	3-1/2	2-5/8	2-15/16	6	1-9/16	1/8	45/64	1-5/8	.924		29
140QD23F	646.20	B1	13.78	3-15/16	3-5/8	4	6-5/8	2-9/16	1/8	1-37/64	2-1/2	.924		38
140QD24F	663.00	B1	24.14											41
140QD25F	679.80	B1	25.14											44
140QD26F	699.20	B1	15.46											46
140QD30F	826.00	B1	17.70	3-15/16	3-5/8	4	6-5/8	2-9/16	1/8	1-37/64	2-1/2	.924		70
140QD35F	1005.80	C	20.49	3-15/16	3-5/8	4	6-5/8	1	1-11/16	1-37/64	2-1/2	.924		82
140QD36F	1065.20	C	21.05	3-15/16	3-5/8	4	6-5/8	1	1-11/16	1-37/64	2-1/2	.924		85
140QD40J	1115.20	C	23.29	4-7/16	4-1/2	5	7-1/4	1-3/16	2-3/8	2-17/64	3-3/16	.924		98
140QD45J	1309.60	C	26.08											120
140QD48J	1446.30	C	27.75											130
140QD54J	1791.20	C	31.10											150
140QD60J	1877.60	C	34.44	4-7/16	4-1/2	5	7-1/4	1-3/16	2-3/8	2-17/64	3-3/16	.924		190
140QD70M	2560.40	C1	40.02	5-1/2	6-3/4	6-3/4	9	2-29/32	2-29/32	2-17/32	5-3/16	.924	1-13/32	290
140QD80M	3233.00	C1	45.59	5-1/2	6-3/4	6-3/4	9	2-29/32	2-29/32	2-17/32	5-3/16	.924	1-13/32	372

Harden per tooth\$ 3.34

QD Bushing dimensions and prices page 10

RYLE P/N	LIST PRICE
140QD11HSF	358.80
140QD12HSF	425.20
140QD13HSF	448.00
140QD14HE	466.80
140QD15HE	493.20
140QD16HE	526.00
140QD17HE	551.60
140QD18HE	578.60
140QD19HE	610.40
140QD20HE	679.80
140QD21HE	694.40
140QD22HE	720.80
140QD23HF	730.40
140QD24HF	749.80
140QD25HF	771.40
140QD26HF	793.20
140QD30HF	933.00

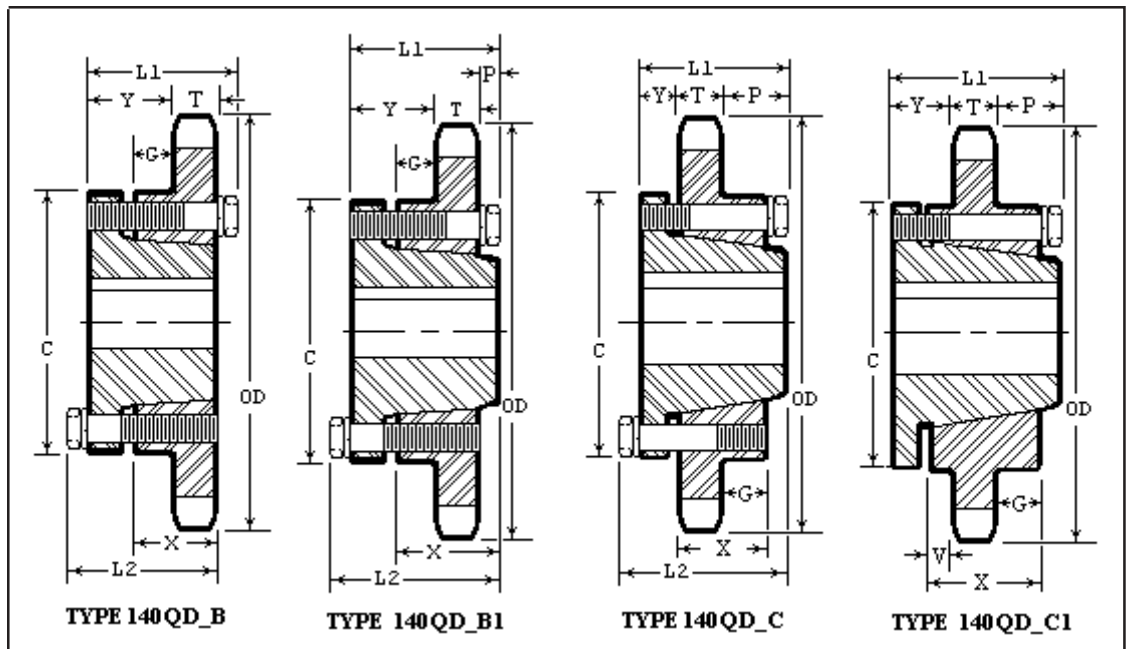



RYLE Manufacturing Company 1-800-433-0960

No. 140-2 Double Strand 1-3/4" Pitch

RYLE P/N	LIST PRICE	NO. TEETH	O.D. TEETH	STOCK BORE	MAX BORE	HUB DIA.	LTB	LBS.
D140B11	681.60	11	7.01	1-1/2	2-3/4	4-1/4	3-3/4	18
D140B12	700.00	12	7.58		3	4-1/2		22
D140B13	711.80	13	8.15		3-5/16	5		30
D140B14	758.00	14	8.72		3-3/4	6		36
D140B15	912.20	15	9.28		4-1/2	6-1/2		40
D140B16	974.40	16	9.85		5-1/4	7	4	62
D140B17	1020.80	17	10.41					75
D140B18	1144.20	18	10.98					80
D140B19	1206.40	19	11.54					83
D140B20	1314.00	20	12.10					88
D140B21	1424.80	21	12.66					95
D140B22	1444.20	22	13.22					133
D140B23	1487.60	23	13.78					143
D140B24	1571.80	24	14.34					153
D140B25	1612.80	25	14.90					163
D140B26	1656.20	26	15.46					173
D140B30	2111.00	30	17.70		5-3/8	7-1/2	4	180
D140B32	2138.40	32	18.82					185
D140C35	2092.60	35	20.49	2			6	207
D140C40	3288.00	40	23.29					210
D140C45	2799.00	45	26.08					170
D140C54	4636.90	54	31.10					264
D140C60	3818.80	60	34.44		6-1/2	9-1/2	6-1/4	267
D140C70	7265.20	70	40.20					330

Maximum bores will accommodate standard keyway and setscrew over key. Slightly larger bores may be possible with shallow keyway and/or setscrew at 90 degrees. Multiple keyways must be priced at factory.

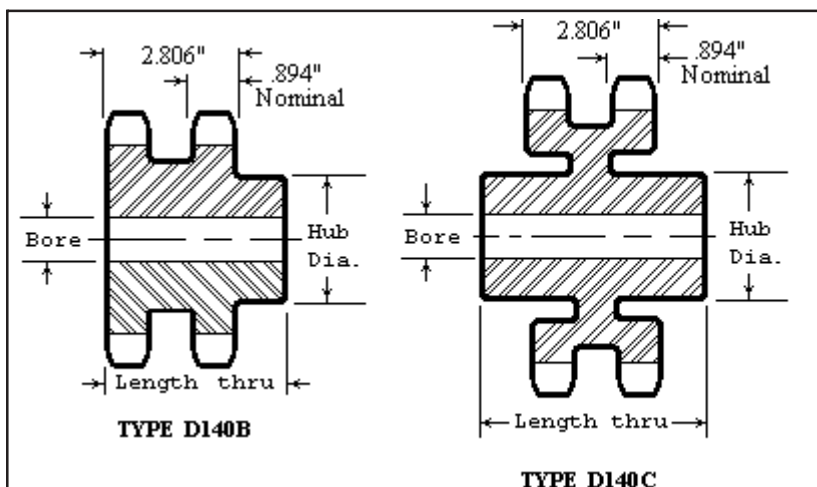

Rebore	\$49.00
Keyway	\$13.40
Setscrew (each)	\$13.40
Harden per tooth	\$ 3.34

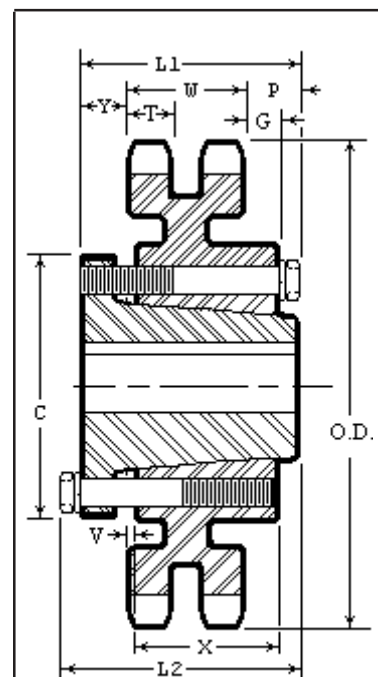

TYPE D140QD_C5

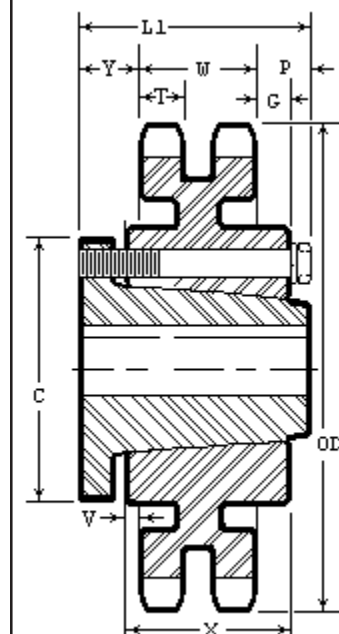

TYPE D140QD_C6

RYLE P/N	LIST PRICE	O.D. TEETH	MAX BORE	TYPE MOUNT	DIMENSIONS	LBS.
					L1 L2 C Y P G V X T W	
D140QD35J	2343.40	20.49	4-7/16	C5	4-1/2 5 7-1/4 31/32 23/32 19/32 7/32 3-3/16 .894 2.806	183
D140QD45J	3271.60	26.08		C5		244
D140QD60M	4252.80	34.44	6-3/4	C6	6-3/4 6-3/4 9 2-27/32 1-23/32 1-19/32 25/32 5-3/16 .894 2.806	391

Harden per tooth\$ 3.34

QD Bushing dimensions and prices page 10



RYLE Manufacturing Company 1-800-433-0960

No. 140-3 Triple Strand 1-3/4" Pitch

RYLE P/N	LIST PRICE	NO. TEETH	O.D. TEETH	STOCK BORE	MAX BORE	HUB DIA.	LTB	LBS.
E140B11	1022.40	11	7.01	1-1/2	2-3/4	4-1/4	5-3/4	39
E140B12	1050.00	12	7.58		3	4-1/2		45
E140B13	1228.70	13	8.15		3-5/16	5		52
E140B14	1562.00	14	8.72		3-3/4	6		58
E140B15	1720.00	15	9.28		4-1/2	6-1/2		66
E140B16	1804.70	16	9.85					74
E140B17	2120.00	17	10.41	2	5-1/4	7	6-3/8	80
E140B18	2250.10	18	10.98					95
E140B19	2372.30	19	11.54					108
E140B20	2454.60	20	12.10					120
E140B21	2653.20	21	12.66					130
E140B22	3120.00	22	13.22					145
E140B23	3367.10	23	13.78					158
E140B24	3487.80	24	14.34					172
E140B25	3660.00	25	14.90					180
E140B26	3924.00	26	15.46					198
E140C35	5324.00	35	20.49	2	5-1/2	8	6-1/2	170
E140C40	6564.40	40	23.29					215
E140C45	7260.00	45	26.08					265
E140C60	9360.00	60	34.44					410

Maximum bores will accommodate standard keyway and setscrew over key. Slightly larger bores may be possible with shallow keyway and/or setscrew at 90 degrees.
Multiple keyways must be priced at factory.

Rebore	\$49.00
Keyway	\$13.40
Setscrew (each)	\$13.40
Harden per tooth	\$ 3.34

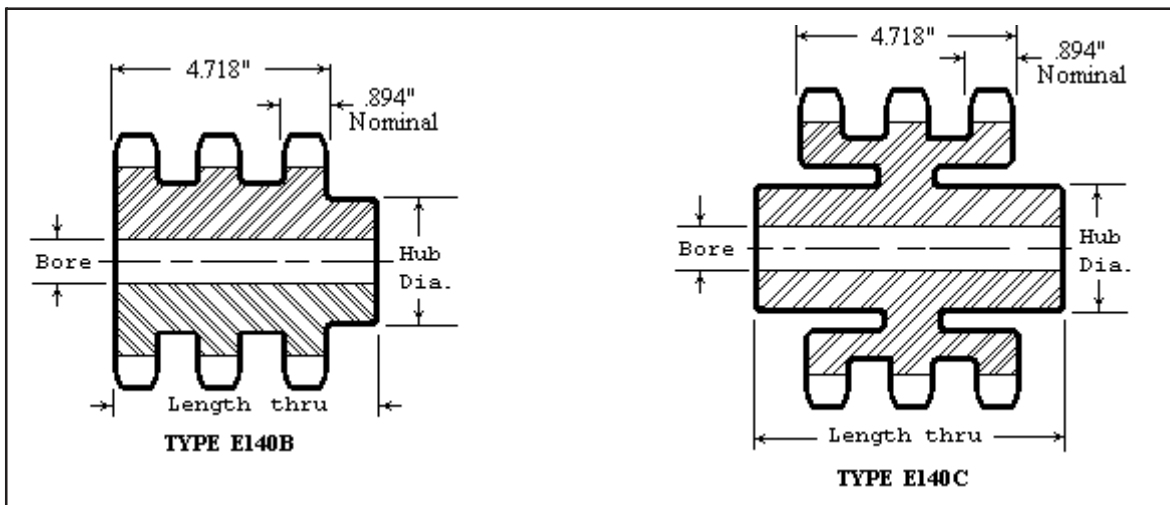



RYLE Manufacturing Company 1-800-433-0960

No. 160 2" Pitch

Type B & C

Type A

RYLE P/N	LIST PRICE	NO. TEETH	O.D. TEETH	STOCK BORE	MAX BORE	HUB DIA.	LTB	LBS.	RYLE P/N	LIST PRICE	LBS.
160B8	294.20	8	6.03	1-1/2	1-7/8	2-51/64	2-1/4	10	160A8	193.40	7
160B9	309.60	9	6.70		2-3/8	3-5/8		12	160A9	201.00	9
160B10	325.00	10	7.36		2-3/4	4		15	160A10	208.80	11
160B11	369.80	11	8.01		3-3/8	5	2-1/2	18	160A11	224.20	13
160B12	415.20	12	8.66		3-3/4	5-1/2		21	160A12	243.00	15
160B13	463.80	13	9.31		4	6	2-3/4	28	160A13	259.40	18
160B14	502.80	14	9.96		4-1/2	6-1/2		30	160A14	281.60	20
160B15	549.20	15	10.61		5-1/4	7		37	160A15	304.80	23
160B16	595.60	16	11.28					42	160A16	328.00	26
160B17	641.80	17	11.90					46	160A17	348.20	30
160B18	688.00	18	12.54					49	160A18	371.20	33
160B19	734.80	19	13.19					53	160A19	394.40	37
160B20	781.00	20	13.83					57	160A20	448.40	41
160B21	827.40	21	14.47					61	160A21	479.80	45
160B22	896.80	22	15.11					65	160A22	487.40	49
160B23	928.20	23	15.75					70	160A23	510.60	54
160B24	959.00	24	16.39				3	78	160A24	526.00	59
160B25	989.00	25	17.03					82	160A25	556.80	63
160B26	1013.00	26	17.67					87	160A26	587.80	68
160B27	1121.00	27	18.31					95	160A27	657.20	74
160B28	1160.00	28	18.95	2				98	160A28	696.20	79
160B30	1314.40	30	20.23					112	160A30	765.60	91
160B32	1402.00	32	21.51					116	160A32	867.60	105
160C35	1438.20	35	23.42		5-1/2	8	4-1/2	170	160A35	1020.80	125
160C36	1498.20	36	24.06					175	160A36	1084.60	134
160C40	1739.60	40	26.61					200	160A40	1322.00	160
160C42	1956.60	42	27.88					210	160A42	1480.00	180
160C45	2150.40	45	29.80				5	245	160A45	1629.80	200
160C48	2293.80	48	31.71					295	160A48	1890.00	234
160C54	2890.60	54	35.54					340	160A54	2275.80	295
160C60	3093.20	60	39.36					410	160A60	2803.80	365
160C70	3924.80	70	45.73					540	160A70	3638.00	495
160C80	4773.40	80	52.10					735	160A80	4378.20	685

Maximum bores will accommodate standard keyway and setscrew over key. Slightly larger bore may be possible with shallow keyway and/or setscrew at 90 degrees. Multiple keyways must be priced at factory.

Rebore	\$49.00
Keyway	\$13.40
Setscrew (each)	\$13.40
Harden per tooth	\$ 4.36

Split Type A plate.....\$ 6.88
per inch of sprocket diameter

Drill Type A plate	(4) holes = \$28.00
	(6) holes = \$42.00
	(8) holes = \$56.00

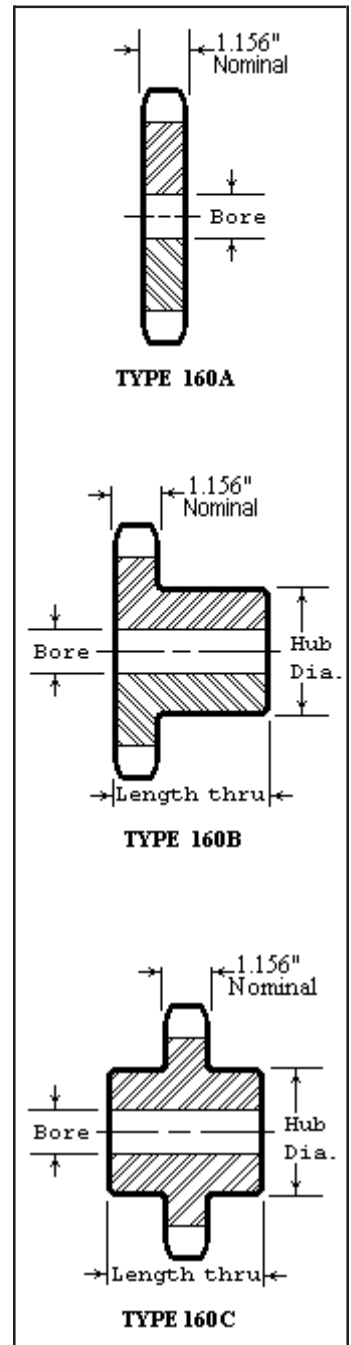



RYLE Manufacturing Company 1-800-433-0960

No. 160 2" Pitch

RYLE P/N	LIST PRICE	TYPE MOUNT	O.D. TEETH	MAX BORE	L1	L2	C	Y	P	G	X	T	LBS.
160QD12E	479.40	B1	8.66	3-1/2	2-5/8	2-15/16	6	1-5/16	1/8	15/32	1-5/8	1.156	12
160QD13E	523.60	B1	9.31										14
160QD14E	576.20	B1	9.96	3-1/2	2-5/8	2-15/16	6	1-5/16	1/8	15/32	1-5/8	1.156	17
160QD15F	557.40	B1	10.61	3-15/16	3-5/8	4	6-5/8	2-5/16	1/8	1-11/32	2-1/2	1.156	25
160QD16F	624.40	B1	11.26										28
160QD17F	668.80	B1	11.90										31
160QD18F	706.40	B1	12.54										36
160QD19F	826.00	B1	13.19										40
160QD20F	848.60	B1	13.83										44
160QD21F	886.20	B1	14.74										48
160QD22F	968.20	B1	15.11										56
160QD23F	1035.20	B1	15.75										64
160QD24F	1056.00	B1	16.39										68
160QD25F	1095.60	B1	17.03	3-15/16	3-5/8	4	6-5/8	2-5/16	1/8	1-11/32	2-1/2	1.156	71
160QD26J	1125.40	C	17.67	4-7/16	4-1/2	5	7-1/4	1-3/16	2-1/8	2-1/32	3-3/16	1.156	75
160QD27J	1160.00	C	18.31										85
160QD28J	1215.00	C	18.95										96
160QD30J	1374.20	C	20.23										104
160QD35J	1513.60	C	23.42	4-7/16	4-1/2	5	7-1/4	1-3/16	2-1/8	2-1/32	3-3/16	1.156	112
160QD40M	1822.60	C1	26.61	5-1/2	6-3/4	6-3/4	9	2-11/16	2-11/16	2-13/32	5-3/16	1.156	135
160QD45M	2256.60	C1	29.80										186
160QD54M	3032.80	C1	35.54										247
160QD60M	3246.00	C1	39.36										342
160QD70M	4120.20	C1	45.73										434
160QD80M	5012.20	C1	52.10	5-1/2	6-3/4	6-3/4	9	2-11/16	2-11/16	2-13/32	5-3/16	1.156	510

Harden per tooth\$ 4.36
 QD Bushing dimensions and prices page 10

RYLE P/N	LIST PRICE
160QD12HE	452.40
160QD13HE	581.40
160QD14HE	638.00
160QD15HF	680.40
160QD16HF	695.80
160QD17HF	744.00
160QD18HF	786.40
160QD19HF	910.40
160QD20HF	937.80
160QD21HF	979.40
160QD22HF	1066.00
160QD23HF	1138.00
160QD24HF	1171.20
160QD25HF	1202.00
160QD26HJ	1236.20
160QD27HJ	1277.80
160QD28HJ	1251.80
160QD30HJ	1410.40

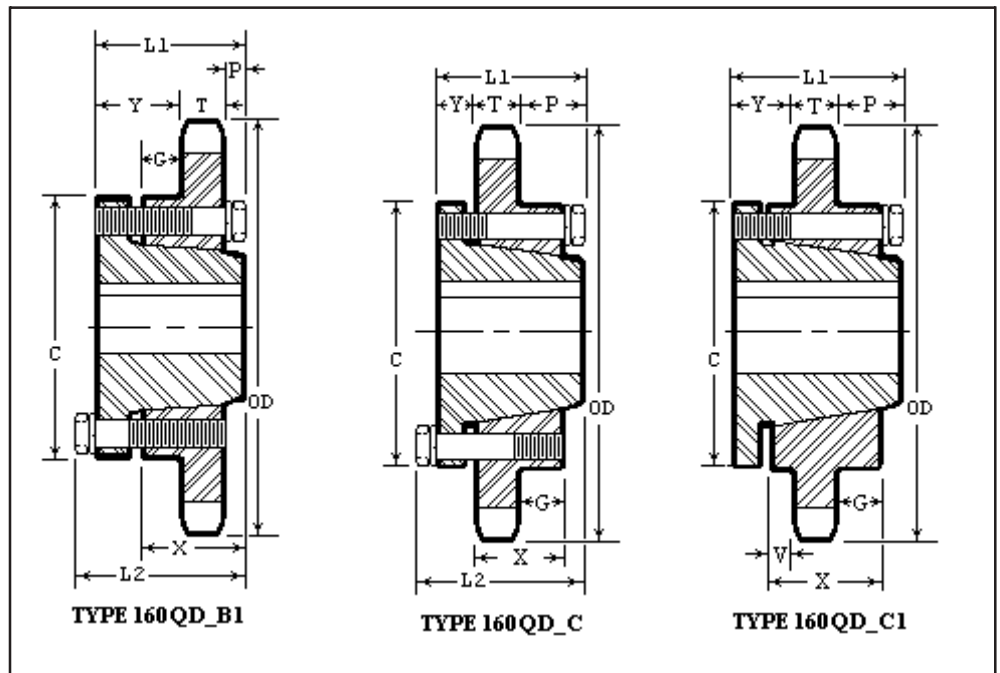



RYLE Manufacturing Company 1-800-433-0960

No. 160-2 Double Strand 2" Pitch

RYLE P/N	LIST PRICE	NO. TEETH	TYPE	O.D. TEETH	STOCK BORE	MAX BORE	HUB DIA.	LTB	LBS.
D160B12	1030.00	12	B	8.66	2	3-3/4	5-1/2	4-3/4	42
D160B13	1041.40	13	B	9.31		4	6-1/4		49
D160B14	1154.80	14	B	9.93		4-3/4	6-3/4		74
D160B15	1188.60	15	B	10.61		5	7		84
D160B16	1275.40	16	B	11.26		5-3/8	7-1/2		94
D160B17	1359.60	17	B	11.90					104
D160B18	1444.20	18	B	12.54					114
D160B19	1528.40	19	B	13.19					124
D160B20	1699.60	20	B	13.83					134
D160B21	1868.40	21	B	14.47					147
D160B22	1996.20	22	B	15.11					158
D160B23	2165.00	23	B	15.75					171
D160B24	2338.60	24	B	16.39					120
D160B25	2507.20	25	B	17.03					135
D160B26	2635.00	26	B	17.67					160
D160B28	2910.60	28	B	18.95					195
D160B30	3220.40	30	B	20.23					270
D160B32	3325.20	32	B	21.51					290
D160C35	3346.20	35	C	23.42		6-3/4	9-1/2	7-1/8	297
D160C40	4640.00	40	C	26.61					310
D160C45	4674.60	45	C	29.80		7	10		381
D160C48	5905.60	48	C	31.71					395
D160C54	6610.40	54	C	35.54					485
D160C60	6678.00	60	C	39.36					510
D160C70	10891.30	70	C	45.73					610

Rebore	\$49.00
Keyway	\$13.40
Setscrew (each)	\$13.40
Harden per tooth	\$ 4.36

Maximum bores will accommodate standard keyway and setscrew over key. Slightly larger bores may be possible with shallow keyway and/or setscrew at 90 degrees. Multiple keyways must be priced at factory.

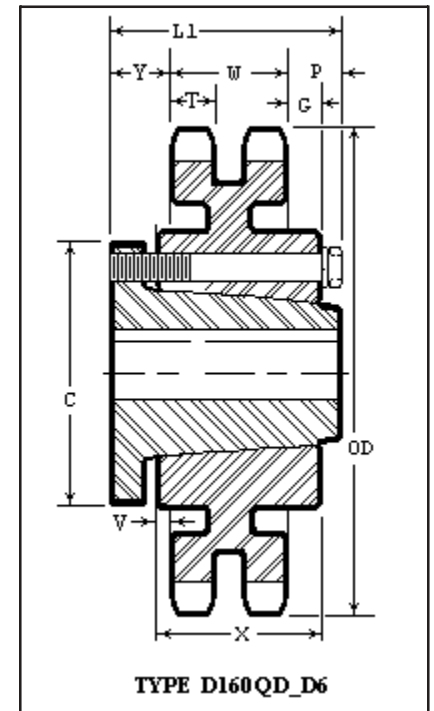
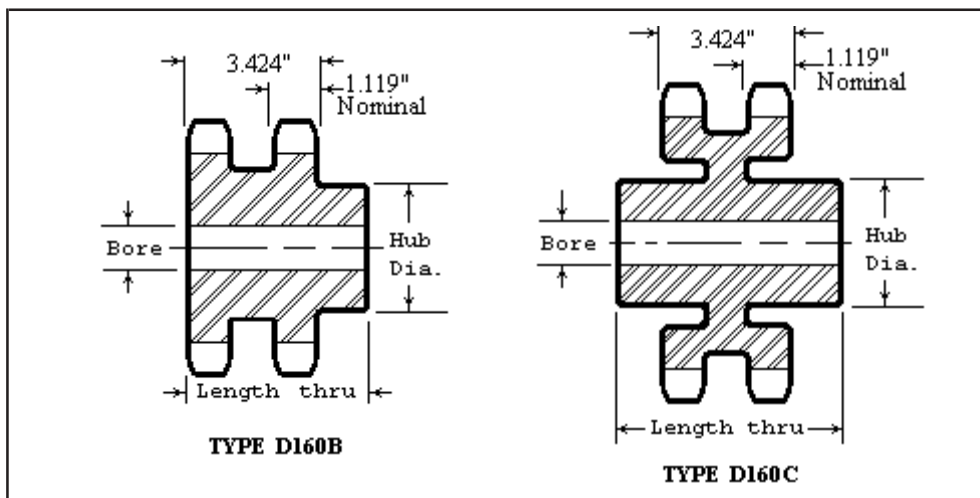

RYLE P/N	LIST PRICE	O.D. TEETH	MAX BORE	TYPE MOUNT	L1	L2	C	DIMENSIONS				LBS			
								Y	P	G	V	X	T	W	
D160QD35M	3406.60	23.42	5-1/2	C6	6-3/4	6-3/4	9	2-3/64	1-9/32	1-5/32	39/64	5-3/16	1.119	3.424	242
D160QD45N	4841.00	29.80	5-7/8	C6	8-1/8	8-1/8	10	2-11/32	2-23/64	2-5/32	21/32	6-1/4	1.119	3.424	360
D160QD60N	7965.40	39.36	5-7/8	C6	8-1/8	8-1/8	10	2-11/32	2-23/64	2-5/32	21/32	6-1/4	1.119	3.424	490

Harden per tooth\$ 4.36

QD Bushing dimensions and prices page 10



RYLE Manufacturing Company 1-800-433-0960

No. 160-3 Triple Strand 2" Pitch

RYLE P/N	LIST PRICE	NO. TEETH	O.D. TEETH	STOCK BORE	MAX BORE	HUB DIA.	LTB	LBS.
E160B12	1845.40	12	8.66	2	3-3/4	5-1/2	6-7/8	52
E160B13	1962.10	13	9.31		4	6-1/4		63
E160B14	2132.20	14	9.96		4-3/4	6-3/4		75
E160B15	2282.90	15	10.61		5	7-3/8	7	98
E160B16	2363.10	16	11.26		5-1/2	8	7-3/8	115
E160B17	2439.40	17	11.90					125
E160B18	2466.30	18	12.54					149
E160B19	2792.60	19	13.19				7-1/2	162
E160B20	3104.30	20	13.83					172
E160B21	3202.60	21	14.47					185
E160B22	3696.30	22	15.11					215
E160B23	3810.80	23	15.75					240
E160B24	4007.90	24	16.39				7-5/8	265
E160B25	4360.80	25	17.03					295
E160B26	4552.50	26	17.67					305
E160C30	6502.30	30	20.22				7-1/4	265
E160C35	7719.30	35	23.42		6-3/4	9-1/2		280
E160C40	9232.80	40	26.61				7-1/2	380
E160C45	10411.90	45	29.80		7	10		420
E160C60	13970.00	60	39.36					735

Maximum bores will accommodate standard keyway and setscrew over key. Slightly larger bores may be possible with shallow keyway and/or setscrew at 90 degrees. Multiple keyways must be priced at factory.

Rebore	\$49.00
Keyway	\$13.40
Setscrew (each)	\$13.40
Harden per tooth	\$ 4.36

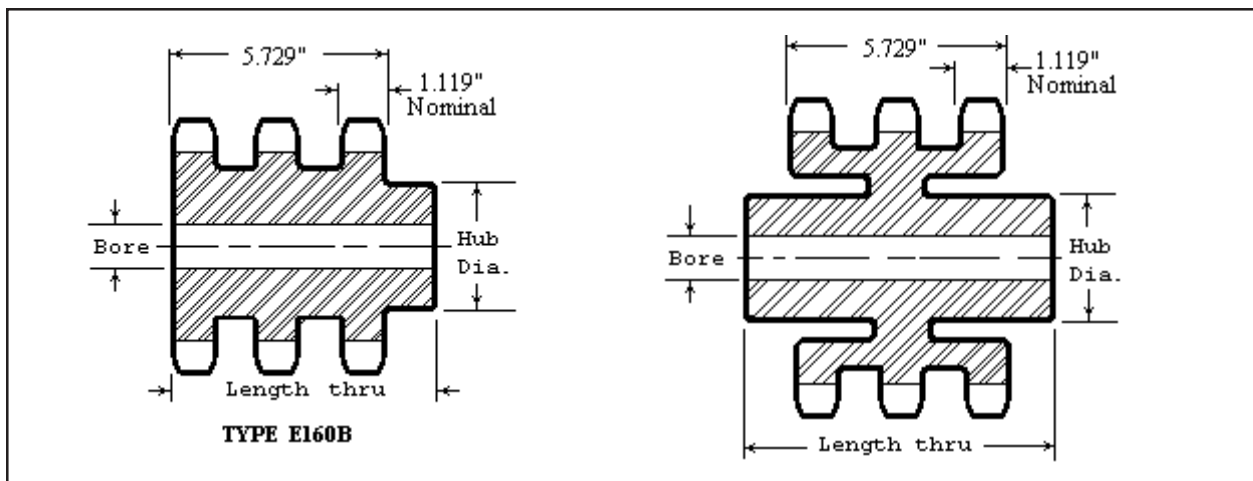



RYLE Manufacturing Company 1-800-433-0960

No. 180 2-1/4" Pitch

Type B & C

Type A

RYLE P/N	LIST PRICE	NO. TEETH	O.D. TEETH	STOCK BORE	MAX BORE	HUB DIA.	LTB	LBS.	RYLE P/N	LIST PRICE	LBS.
180B11	574.80	11	9.01	1-1/2	3-3/8	5-1/4	2-3/4	27	180A11	421.40	18
180B12	581.00	12	9.75		4	6		32	180A12	431.00	22
180B13	626.40	13	10.48		4-1/2	6-1/2		41	180A13	463.40	26
180B14	664.80	14	11.21		5-3/8	7-1/4	3	50	180A14	495.20	30
180B15	734.80	15	11.93					58	180A15	525.20	34
180B16	788.80	16	12.66					63	180A16	568.40	39
180B17	850.60	17	13.39					68	180A17	618.60	45
180B18	904.60	18	14.11				3-1/4	74	180A18	664.80	49
180B19	959.00	19	14.83					79	180A19	693.80	55
180B20	1005.40	20	15.56					85	180A20	742.60	60
180B21	1059.40	21	16.28					91	180A21	781.00	67
180B22	1121.00	22	17.00					98	180A22	920.00	74
180B23	1167.80	23	17.72					105	180A23	974.40	81
180B24	1299.00	24	18.44				3-1/2	117	180A24	1036.20	88
180B25	1438.20	25	19.16					138	180A25	1272.00	96
180B26	1551.60	26	19.88		5-1/2	8		150	180A26	1350.60	102
180B28	1778.20	28	21.32					158	180A28	1507.80	128
180C30	2010.20	30	22.76	2			4-1/2	188	180A30	1778.20	136
180C35	2203.40	35	26.25				5	255	180A35	1971.60	188
180C40	2435.40	40	29.94					300	180A40	2203.40	240
180C45	2976.80	45	33.53		6	9	5-1/2	388	180A45	2706.00	304
180C54	3711.20	54	39.98					528	180A54	3015.60	440
180C60	4553.60	60	44.28					630	180A60	4175.20	550

Maximum bores will accommodate standard keyway and setscrew over key. Slightly larger bore may be possible with shallow keyway and/or setscrew at 90 degrees. Multiple keyways must be priced at factory.

Split Type A plate	\$ 7.54
per inch of sprocket diameter	
Rebore	\$49.00
Keyway	\$13.40
Setscrew (each)	\$13.40
Harden per tooth	\$ 4.88
Drill Type A plate	(4) holes = \$28.00
	(6) holes = \$42.00
	(8) holes = \$56.00

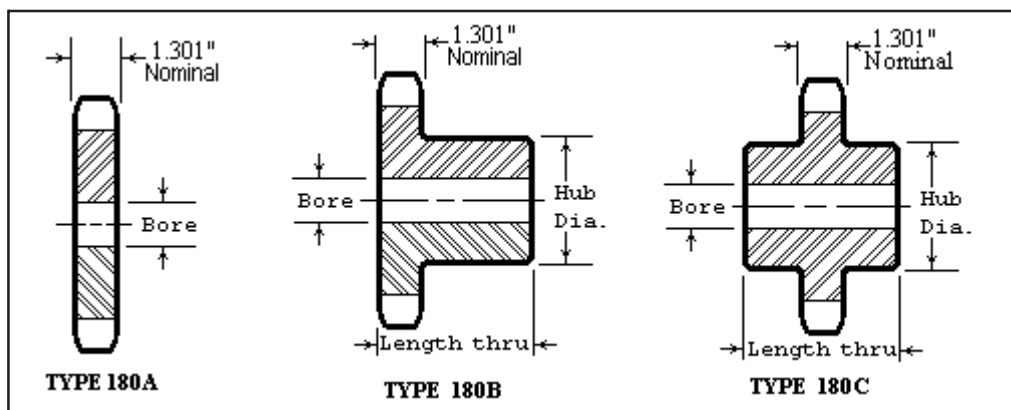



RYLE Manufacturing Company 1-800-433-0960

No. 180-2 Double Strand 2-1/4" Pitch

RYLE P/N	LIST PRICE	NO. TEETH	TYPE	O.D. TEETH	STOCK BORE	MAX BORE	HUB DIA.	LTB	LBS.
D180B12	1227.40	12	B	9.75	2	4	6	5-1/4	89
D180B13	1284.90	13	B	10.48		4-1/2	6-1/2		95
D180B14	1405.50	14	B	11.21		5-3/8	7-1/2		100
D180B15	1464.60	15	B	11.93					105
D180B16	1680.40	16	B	12.66					110
D180B17	1791.20	17	B	13.39					115
D180B18	1880.50	18	B	14.11					130
D180B19	1991.30	19	B	14.83					160
D180B20	2148.10	20	B	15.56					180
D180B21	2279.50	21	B	16.28					210
D180B22	2412.10	22	B	17.00					220
D180B23	2566.40	23	B	17.72					240
D180B24	2746.00	24	B1	18.44					180
D180B25	2921.90	25	B1	19.16					195
D180B26	3101.50	26	B1	19.88					205
D180B30	3650.20	30	B1	22.75					230
D180C35	4340.70	35	C	26.35				6-1/2	268
D180C40	5210.60	40	C	29.94		6	9		310
D180C45	5862.00	45	C	33.53				7-1/4	445
D180C60	8533.20	60	C	44.28					610

Maximum bores will accommodate standard keyway and setscrew over key. Slightly larger bores may be possible with shallow keyway and/or setscrew at 90 degrees. Multiple keyways must be priced at factory.

Rebore	\$49.00
Keyway	\$13.40
Setscrew (each)	\$13.40
Harden per tooth	\$ 4.88

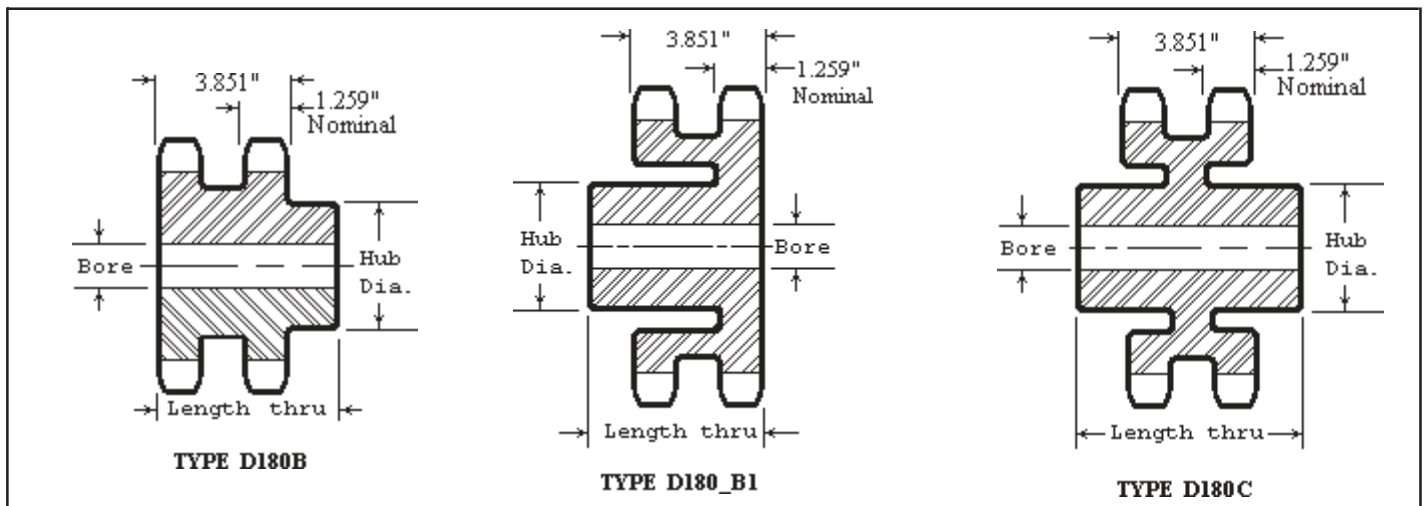



RYLE Manufacturing Company 1-800-433-0960

No. 200 2-1/2" Pitch

Type B & C

Type A

RYLE P/N	LIST PRICE	NO. TEETH	O.D. TEETH	STOCK BORE	MAX BORE	HUB DIA.	LTB	LBS.	RYLE P/N	LIST PRICE	LBS.
		9	8.37	1-3/8					200A9	425.00	14
200B10	556.80	10	9.20	1-1/2	3-3/4	5-1/2	3	26	200A10	433.00	16
200B11	605.20	11	10.02		4	6		35	200A11	463.80	24
200B12	651.40	12	10.83		4-1/2	6-1/2		42	200A12	541.40	28
200B13	683.20	13	11.64		5-1/8	7		48	200A13	572.40	32
200B14	716.00	14	12.46		5-3/8	7-1/2	3-1/2	65	200A14	618.60	38
200B15	838.60	15	13.26					70	200A15	711.80	44
200B16	962.00	16	14.07					76	200A16	788.80	50
200B17	1002.00	17	14.87					82	200A17	858.20	56
200B18	1036.20	18	15.68					89	200A18	912.20	63
200B19	1104.20	19	16.48					96	200A19	959.00	70
200B20	1138.40	20	17.29					104	200A20	1005.40	78
200B21	1171.80	21	18.08					112	200A21	1043.80	85
200B22	1399.80	22	18.89		5-3/4	8-1/2	4	135	200A22	1198.60	95
200B23	1469.20	23	19.69					143	200A23	1275.80	103
200B24	1662.60	24	20.49					152	200A24	1392.00	112
200B25	1933.00	25	21.29					161	200A25	1624.00	121
200C26	2010.20	26	22.09	2			4-1/2	185	200A26	1701.00	132
200C28	2165.00	28	23.69					200	200A28	1855.80	148
200C30	2242.00	30	25.29					220	200A30	1933.00	170
200C32	2551.60	32	26.88					244	200A32	2165.00	199
200C35	2583.60	35	29.28					283	200A35	2396.80	238
200C36	2657.40	36	30.07					300	200A36	2460.00	250
200C40	2976.80	40	33.27		6	9	5	360	200A40	2628.80	310
200C42	3125.60	42	34.86					405	200A42	2880.00	345
200C45	3399.40	45	37.27					442	200A45	3059.40	392
200C48	3626.00	48	39.64					500	200A48	3263.40	448
200C54	4166.00	54	44.42		6-1/2	9-1/2	5-1/2	520	200A54	3399.40	560
200C60	5017.00	60	49.20					600	200A60	4590.20	700

Maximum bores will accommodate standard keyway and setscrew over key. Slightly larger bore may be possible with shallow keyway and/or setscrew at 90 degrees. Multiple keyways must be priced at factory.

Split Type A plate \$ 8.00
per inch of sprocket diameter

Rebore \$49.00
Keyway \$13.40
Setscrew (each) \$13.40
Harden per tooth \$ 5.32
Drill Type A plate (4) holes = \$28.00
(6) holes = \$42.00
(8) holes = \$56.00

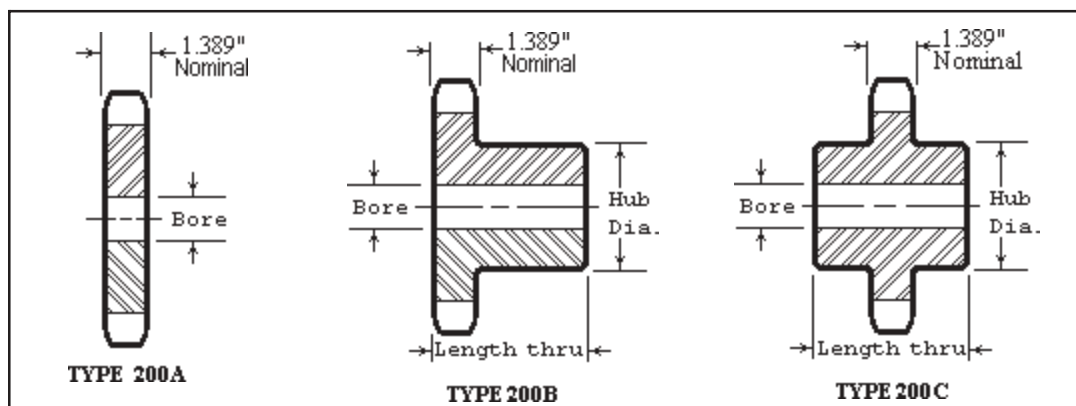



RYLE Manufacturing Company 1-800-433-0960

No. 200 2-1/2" Pitch

RYLE P/N	LIST PRICE	TYPE MOUNT	O.D. TEETH	MAX BORE	L1	L2	C	Y	P	G	V	X	T	LBS.
200QD12F	713.60	C	10.83	3-15/16	3-5/8	4	6-5/8	1	1-5/16	1-1/8		2-1/2	1.301	26
200QD13J	752.20	C	11.64	4-7/16	4-1/2	5	7-1/4	1-3/16	2	1-13/16		3-3/16	1.301	35
200QD14J	790.80	C	12.46											42
200QD15J	921.00	C	13.26											49
200QD16J	1056.00	C	14.07	4-7/16	4-1/2	5	7-1/4	1-3/16	2	1-13/16		3-3/16	1.301	56
200QD17M	1094.40	C1	14.87	5-1/2	6-3/4	6-3/4	9	2-23/32	2-23/32	2-5/16	1-1/2	5-3/16	1.301	82
200QD18M	1138.00	C1	15.68											90
200QD19M	1157.20	C1	16.48											100
200QD20M	1191.00	C1	17.29											109
200QD21M	1229.60	C1	18.09											115
200QD22M	1465.80	C1	18.89											123
200QD23M	1543.00	C1	19.69											129
200QD24M	1745.40	C1	20.49											141
200QD25M	2025.20	C1	21.29											153
200QD26M	2102.20	C1	22.09											161
200QD28M	2271.00	C1	23.69											183
200QD30M	2353.00	C1	25.29											260
200QD32M	2676.00	C1	26.88											280
200QD35M	2917.20	C1	29.28											315
200QD40M	3110.00	C1	33.27	5-1/2	6-3/4	6-3/4	9	2-23/32	2-23/32	2-5/16	1-1/2	5-3/16	1.301	400
200QD45N	3601.80	C1	37.25	5-7/8	8-1/8	8-1/8	10	3-13/32	3-13/32	3-1/16	1-11/16	6-1/4	1.301	510
200QD54N	4484.20	C1	44.42											700
200QD60N	5607.60	C1	49.20	5-7/8	8-1/8	8-1/8	10	3-13/32	3-13/32	3-1/16	1-11/16	6-1/4	1.301	860

Harden per tooth\$ 5.32

QD Bushing dimensions and prices page 10

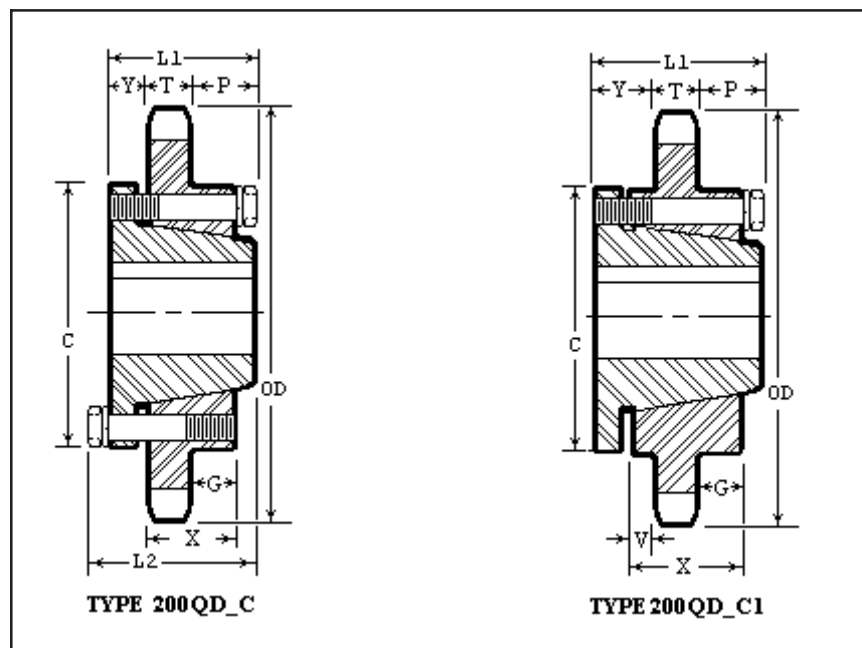



RYLE Manufacturing Company 1-800-433-0960

No. 200-2 Double Strand 2-1/2" Pitch

RYLE P/N	LIST PRICE	NO. TEETH	TYPE	O.D. TEETH	STOCK BORE	MAX BORE	HUB DIA.	LTB	LBS.
D200B11	1275.80	11	B	10.02	2	3-3/4	5-1/2	5-7/8	92
D200B12	1424.80	12	B	10.83		4-1/2	6-1/2	6-3/8	116
D200B13	1528.40	13	B	11.64		5-1/4	7		132
D200B14	1656.20	14	B	12.46		5-1/2	8		160
D200B15	1740.60	15	B	13.26		5-3/4	8-1/2		185
D200B16	2085.40	16	B	14.07					210
D200B17	2222.80	17	B	14.87					235
D200B18	2316.80	18	B	15.68					255
D200B19	2454.20	19	B	16.48					275
D200B20	2596.60	20	B	17.29					307
D200B21	2690.60	21	B	18.09					330
D200B22	2828.00	22	B1	18.89					240
D200B23	2967.80	23	B1	19.69					255
D200B24	3153.40	24	B1	20.49					270
D200B25	3336.60	25	B1	21.29					295
D200B26	3568.00	26	B1	22.09					310
D200C30	5316.90	30	C	25.29				6-3/4	325
D200C32	6900.25	32	C	26.88					350
D200C35	7682.90	35	C	29.28					400
D200C40	7666.20	40	C	37.25		6	9	7-1/4	465
D200C45	7049.40	45	C	37.25		7	10	8-1/2	790
D200C54	11360.60	54	C	44.42					825
D200C60	10388.40	60	C	49.20				9	1150
D200C70	16950.80	70	C	51.17					1260

Maximum bores will accommodate standard keyway and setscrew over key. Slightly larger bores may be possible with shallow keyway and/or setscrew at 90 degrees. Multiple keyways must be priced at factory.

Rebore	\$49.00
Keyway	\$13.40
Setscrew (each)	\$13.40
Harden per tooth	\$ 5.32

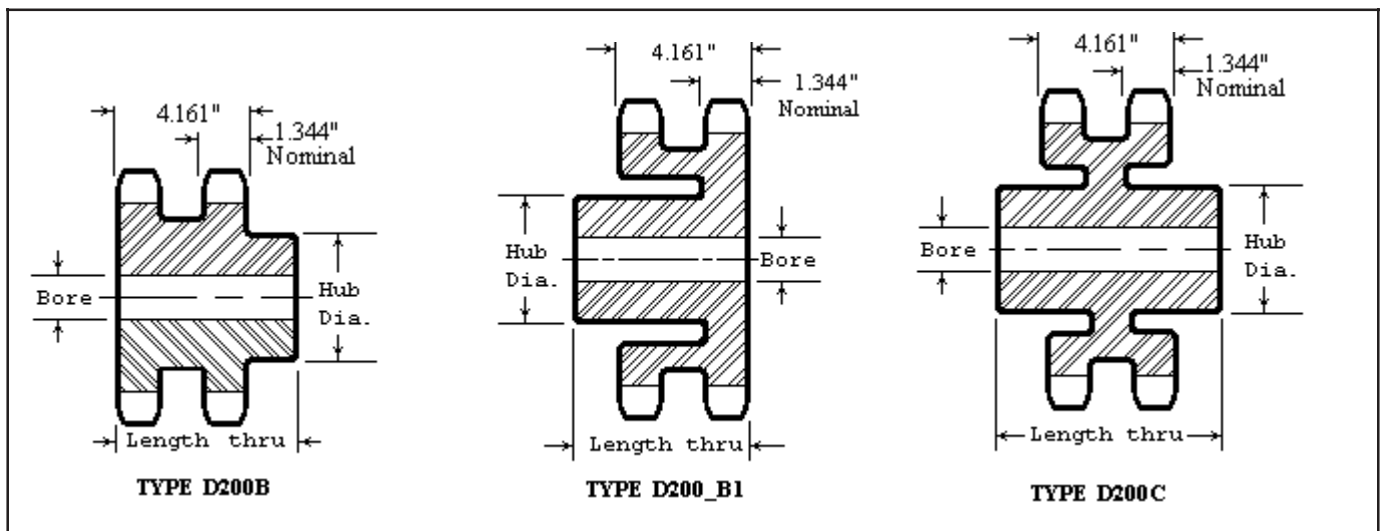



RYLE Manufacturing Company 1-800-433-0960

No. 240 3" Pitch

Type B & C

Type A

RYLE P/N	LIST PRICE	NO. TEETH	O.D. TEETH	STOCK BORE	MAX BORE	HUB DIA.	LTB	LBS.	RYLE P/N	LIST PRICE	LBS.
240B10	1043.80	10	11.03	2	4-1/2	6-1/2	3-3/8	49	240A10	679.80	30
240B11	1059.40	11	12.02		5	7	3-1/2	56	240A11	748.80	36
240B12	1095.00	12	13.00		5-1/2	8		66	240A12	823.60	42
240B13	1161.60	13	13.97		6	9		77	240A13	904.20	48
240B14	1220.00	14	14.94		6-3/4	10	4	103	240A14	984.60	59
240B15	1307.60	15	15.91					112	240A15	1073.40	66
240B16	1484.60	16	16.88					122	240A16	1176.00	75
240B17	1587.20	17	17.85					130	240A17	1278.60	84
240B18	1712.60	18	18.81				4-1/2	146	240A18	1403.60	95
240B19	1838.00	19	19.78					154	240A19	1528.40	105
240B20	1955.20	20	20.74					166	240A20	1652.80	117
240B21	2056.40	21	21.71					178	240A21	1749.80	128
240B25	2594.20	25	25.55					258	240A25	2284.40	182
240C30	3807.60	30	30.34		7-1/2	11	5-1/2	310	240A30	3015.60	263
240C35	5050.80	35	35.13					416	240A35	4202.00	357
240C40	6376.80	40	39.92					530	240A40	5209.80	465
240C45	7430.20	45	44.70		8-3/8	12	6	670	240A45	6299.60	588
240C54	9812.20	54	53.31				6-1/2	925	240A54	8647.80	840
240C60	11514.20	60	59.04					1130	240A60	10337.80	1050

Maximum bores will accommodate standard keyway and setscrew over key. Slightly larger bore may be possible with shallow keyway and/or setscrew at 90 degrees. Multiple keyways must be priced at factory.

Split Type A plate	\$ 8.88
per inch of sprocket diameter	
Rebore	\$49.00
Keyway	\$13.40
Setscrew (each)	\$13.40
Harden per tooth	\$ 6.40
Drill Type A plate	(4) holes = \$28.00
	(6) holes = \$42.00
	(8) holes = \$56.00

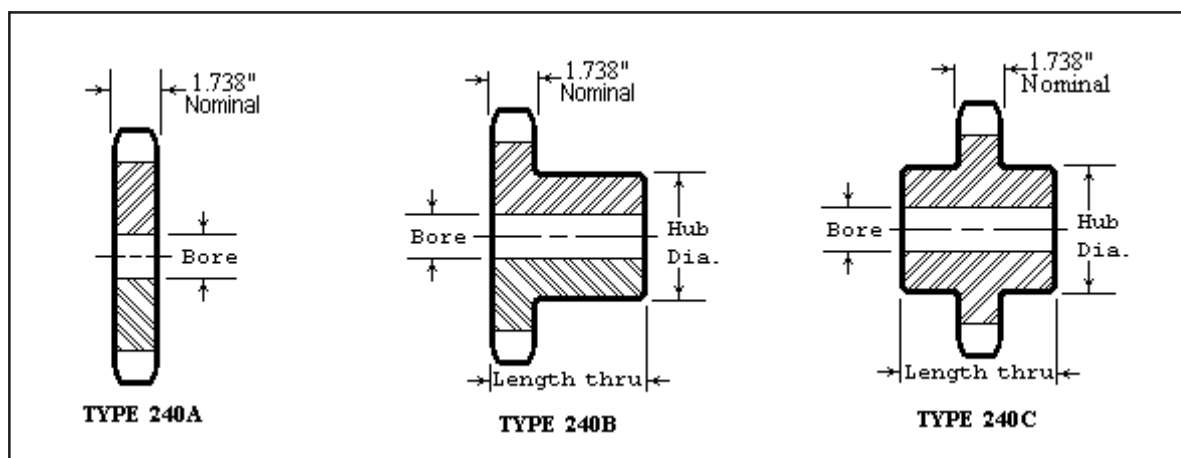



RYLE Manufacturing Company 1-800-433-0960

Split Sprockets

SPLIT HUBS FOR USE WITH TYPE A PLATE (SINGLE STRAND) SPROCKETS ONLY

RYLE P/N	MIN BORE	RANGE	MAX BORE	LIST TYPE B	LIST TYPE C	HUB DIA.	LTB (*)	BOLT SIZE	LBS.
S-1	3/4	-	1-1/2	334.00	400.00	3-1/8	1-1/8	3/8 x 2-1/4	1
S-2	1-3/8	-	2-1/4	368.00	468.00	4-3/8	1-3/8	1/2 x 2-3/4	5
S-3	2	-	3	436.00	600.00	6	1-3/8	5/8 x 4-1/2	12
S-4	2-3/4	-	4	568.00	866.00	7-5/8	1-3/4	3/4 x 5-1/2	22
S-5	3-3/4	-	5	636.00	1168.00	9-1/4	2-1/4	1 x 6	36
S-6	4-3/4	-	6	932.00	1600.00	10-1/4	2-1/4	1 x 6-1/2	48
S-7	5-3/4	-	7	1200.00	1866.00	12-1/2	2-3/4	1 x 7	64
S-8	6-1/4	-	8	1680.00	2168.00	14-1/2	3-1/2	1 x 8	99

(*) Indicates thickness prior to machining. Finished thickness approximately 1/16" to 3/16" thinner.

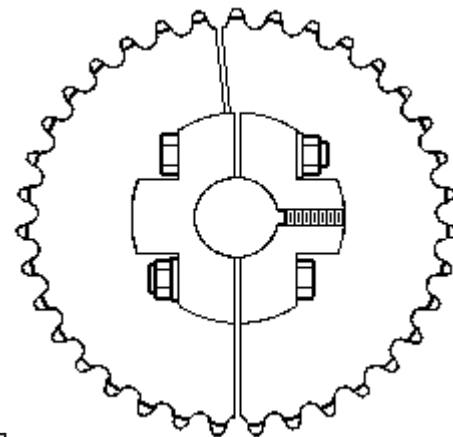

MINIMUM NUMBER OF TEETH (CHART)

for use with split hubs and single row sprockets

CHAIN No.	CHAIN PITCH	S-1	S-2	S-3	S-4	S-5	S-6	S-7	S-8
35	0.375	32	43	59					
41	0.500	24	32	45					
40	0.500	25	33	46	56	64	72		
50	0.625	21	27	37	45	52	58		
60	0.750	18	23	31	38	44	49		
80	1.000	14	18	24	30	34	38		
100	1.250	12	15	20	24	28	31	38	43
120	1.500	11	13	17	21	24	26	32	36
140	1.750	10	12	16	18	21	23	26	32
160	2.000	9	11	14	16	19	21	25	28
180	2.250	9	10	13	15	17	16	22	25
200	2.500	8	9	12	14	16	17	21	23
240	3.000		11	12	14	15	18	20	
2040	1.000	28	36	51	62	70	79		
2042	1.000	14	18	24	30	34	38		
2050	1.250	23	30	41	50	57	64		
2052	1.250	12	15	20	24	28	31	38	43
2060	1.500	20	25	34	42	48	54		
2062	1.500	11	13	17	21	24	26	32	36
2080	2.000	16	20	27	33	37	42		
2082	2.000		11	14	16	19	21	25	28
62	1.654	9	12	15	18	21	23	27	31
78	2.609	7	8	10	12	14	15	18	20
1568	3.067		8	10	12	13	14	16	18
1030	3.075		8	9	11	13	14	16	18
82	3.075		7	9	11	12	13	15	17
238	3.500		8	9	10	12	13	15	16
124	4.000		6	7	9	10	11	12	14
1240	4.063		7	8	9	10	11	13	14
635	4.500			8	9	10	11	12	14
1207	5.000				8	9	10	11	13
132	6.050					7	8	9	10

MACHINE CUT TEETH

FLAME CUT

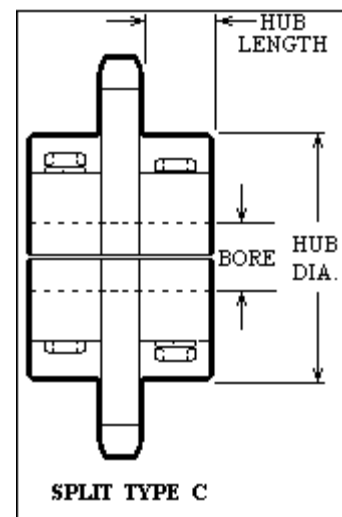
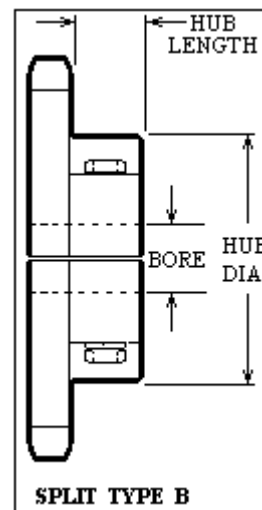



RYLE Manufacturing Company 1-800-433-0960

QD[®] & Stock Bore Chain Coupling Halves

RYLE P/N	LIST PRICE	*MAX* BORE	DIMENSIONS				CHAIN O.D.	F**	LBS.	
			A	B	C	X				
4016JA	52.60	1	2	7/8	1-5/16	9/32	2-29/32	3-1/32	1-1/4	.9
5018SH	75.60	1-1/4	2-21/32	1	1-1/2	3/8	3-3/8	4-3/16	1-3/4	1.3
6020SK	130.40	2	3-7/8	1-1/4	1-7/8	7/16	4-3/16	5-1/2	2-1/4	2.5
8018SF	243.20	2-1/4	4-9/16	1-3/4	2-3/8	37/64	5-21/64	6-21/32	2-1/4	5.3

* Maximum bore * listed above is the maximum bore of the QD bushing with standard keyway. For best results it is recommended that this maximum not be exceeded in both halves of a coupling.

**Minimum clearance required to remove coupling using screws provided as jack screws.

All coupling halves have Induction Hardened Teeth

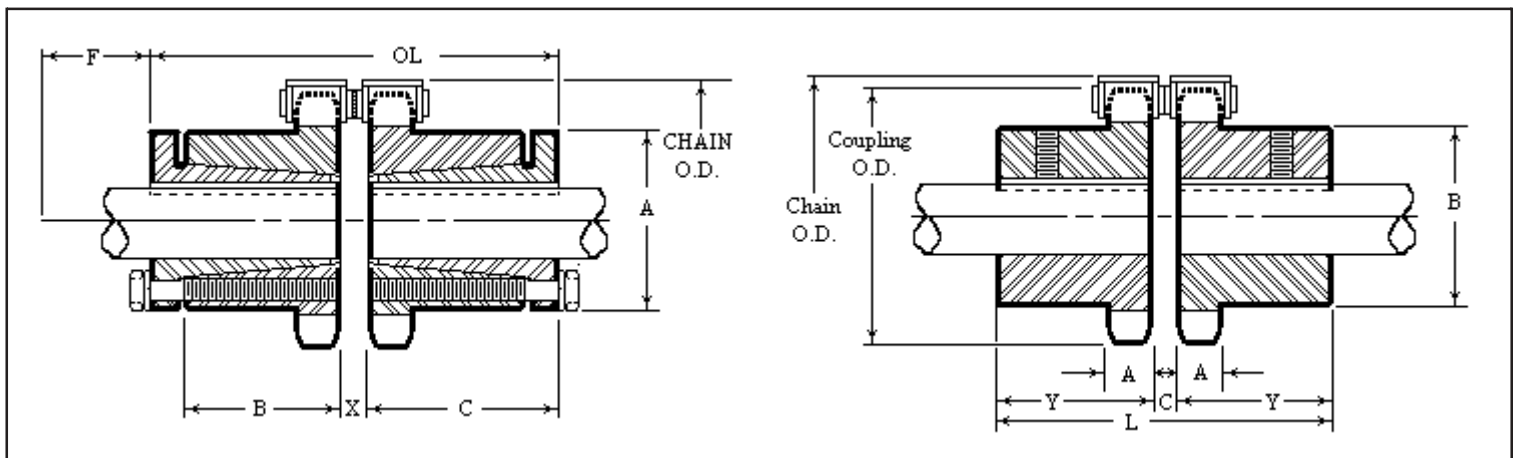

Rebore	\$49.00
Keyway	\$13.40
Setscrew (each)	\$13.40

RYLE P/N	LIST PRICE	STOCK BORE	MAX BORE	LBS	RECOMMENDED MAXIMUM RPM
4012	36.20	1/2	7/8	.5	5000
4016	44.40	5/8	1-5/16	1.0	5000
5016	60.40	5/8	1-11/16	2.0	4000
5018	67.20	3/4	2	2.3	3600
6018	95.60	1	2-7/16	5.0	3000
6020	120.40	1	2-3/4	6.5	2500
6022	181.00	1	3	9.4	2500
8018	224.80	1	3-1/8	11.0	2000
8020	261.00	1-1/2	3-9/16	16.3	2000
10018	505.00	1-1/2	3-7/8	20.3	1800
10020	598.20	1-1/2	4-5/8	31.8	1800
12018	859.40	2	4-11/16	36.8	1500
12022	1488.00	2	6-1/8	70.0	1200

All coupling halves have Induction Hardened Teeth



RYLE Manufacturing Company 1-800-433-0960

Bored to Size Chain Coupling Halves

RYLE P/N	LIST PRICE	TEETH O.D.	CHAIN O.D.	A	DIMENSIONS				AVAILABLE BORE SIZES WITH STANDARD KEY & 2)SS
					B	Y	L	C	
4012	42.00	1.98	2-13/32	.275	1-13/32	1-1/8	2-17/32	9/32	1/2 5/8 3/4
4016	49.80	2.68	3-1/32	.275	1-31/32	1-1/8	2-17/32	9/32	5/8 3/4 7/8 1 1-1/8 1-3/16 1-1/4
5016	66.40	3.29	3-25/32	.332	2-1/2	1-7/16	3-1/4	3/8	3/4 7/8 1 1-1/8 1-3/16 1-1/4 1-3/8 1-7/16 1-1/2 1-5/8
5018	73.60	3.70	4-3/16	.332	2-31/32	1-11/16	3-3/4	3/8	3/4 7/8 1 1-1/8 1-3/16 1-1/4 1-3/8 1-7/16 1-1/2 1-5/8 1-3/4 1-7/8 1-15/16
6018	104.20	4.47	5	.444	3-1/2	1-7/8	4-3/16	7/16	1 1-1/8 1-3/16 1-1/4 1-3/8 1-7/16 1-1/2 1-5/8 1-3/4 1-7/8 1-15/16 2 2-1/8 2-3/16 2-1/4 2-3/8 2-7/16
6020	127.60	4.99	5-1/2	.444	3-7/8	2	4-7/16	7/16	1 1-1/8 1-1/4 1-1/2 1-3/4 1-15/16 2-1/8 2-3/8 2-7/16 2-5/8
6022	188.40	5.45	5-61/64	.444	4-1/2	2-1/8	4-11/16	7/16	1 1-1/8 1-3/4 1-7/8 1-15/16 2-1/8 2-3/8 2-7/16 2-5/8 2-3/4 2-7/8
8018	239.20	5.95	6-21/32	.557	4-9/16	2-3/8	5-21/64	37/64	1 1-1/8 1-3/4 1-15/16 2 2-1/8 2-3/8 2-7/16 2-5/8 2-7/8 2-15/16
8020	285.20	6.60	7-19/64	.557	5-3/8	2-5/8	5-53/64	37/64	1-1/2 2-3/16 2-7/16 2-11/16 2-15/16 3-1/8 3-3/8 3-15/16
10018	547.20	7.50	8-21/64	.669	5-11/16	2-3/4	6-7/32	23/32	1-1/2 2-7/16 2-7/8 2-15/16 3-7/16
10020	644.40	8.25	9-1/8	.669	6-23/32	3-1/8	6-31/32	23/32	2 3-3/8 3-7/16 3-15/16
12018	949.00	8.86	10	.894	6-3/4	3-1/2	7-7/8	55/64	3-7/16 3-15/16 4-7/16
12022	1589.60	10.86	11-57/64	.894	6-3/4	4	8-7/8	55/64	4-3/8 4-7/16 4-15/16

All couplings have Induction Hardened Teeth

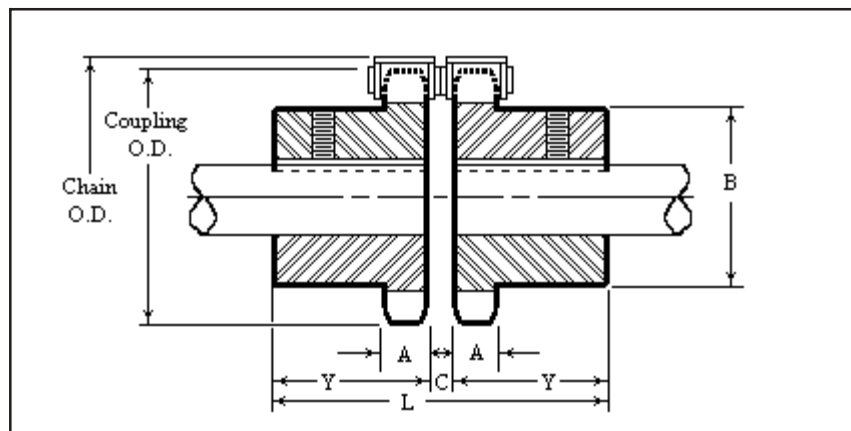



RYLE Manufacturing Company 1-800-433-0960

2040 Extended Pitch 1" Pitch

RYLE P/N	LIST PRICE	O.D. TEETH	P.D. TEETH	STOCK BORE	MAX BORE	HUB DIA.	LTB	LBS.	RYLE P/N	LIST PRICE	LBS.
2040B11	27.20	2.00	1.852	1/2	13/16	1-3/8 *	7/8	.34			
2040B12	29.00	2.17	2.000			1-9/16 *		.44			
2040B13	29.80	2.32	2.152			1-9/16 *		.48			
2040B14	31.60	2.49	2.305		1	1-11/16 *		.60			
2040B15	33.40	2.64	2.458	5/8	1-7/32	1-23/32		.66			
2040B16	34.80	2.81	2.613		1-9/32	1-7/8		.76			
2040B17	36.60	2.97	2.768		1-5/16	2-1/16	1	1.00			
2040B18	40.40	3.14	2.924		1-15/32	2-3/16	1	1.16			
2040B19	45.00	3.29	3.080		1-5/8	2-3/8	1	1.36			
2040B20	50.60	3.46	3.236		1-3/4	2-1/2	1	1.54			
2040B21	56.00	3.61	3.392				1	1.65			
2040B22	61.80	3.78	3.548			2-7/8	1	2.00			
2040B23	69.00	3.93	3.706		2	3	1	2.16	2040A23	34.80	.77
2040B24	71.60	4.10	3.864		2-1/4	3-1/4	1	2.25	2040A24	36.00	.84
2040B25	75.20	4.26	4.021				1	2.30	2040A25	41.00	.91
2040B26	81.00	4.42	4.179				1	2.40	2040A26	44.20	1.00
2040B28	86.80	4.74	4.494				1	2.55	2040A28	47.20	1.10
2040B30	89.40	5.06	4.810	5/8	2-1/4	3-1/4	1	2.74	2040A30	50.40	1.30

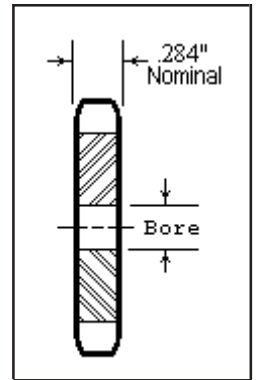

* Indicates hub diameter is grooved for chain clearance.

Maximum bores will accommodate standard keyway and setscrew over key.

Multiple keyways must be priced at factory.

Split Type A plate	\$ 2.76
per inch of sprocket diameter	
Rebore	\$49.00
Keyway	\$13.40
Setscrew (each)	\$13.40
Harden per tooth	\$.94 (2040)
Harden per tooth	\$ 1.78 (2042)
Drill Type A plate	(4) holes = \$28.00
	(6) holes = \$42.00
	(8) holes = \$56.00

2042 Extended Pitch 1" Pitch

RYLE P/N	LIST PRICE	O.D. TEETH	P.D. TEETH	STOCK BORE	MAX BORE	HUB DIA.	LTB	LBS.	RYLE P/N	LIST PRICE	LBS.
2042B8	31.60	3.01	2.613	5/8	1-9/32	1-7/8	7/8	.72			
2042B9	40.00	3.35	2.924		1-15/32	2-7/32		1.02			
2042B10	51.20	3.68	3.236		1-3/4	2-35/64	1	1.50			
2042B11	62.40	4.01	3.549		1-7/8	2-5/8	1	1.68			
2042B12	71.60	4.33	3.864		2-1/4	3-1/16	1	2.22			
2042B13	79.60	4.66	4.179			3-1/4	1	2.56			
2042B14	84.60	4.98	4.494				1	2.72			
2042B15	89.40	5.31	4.810				1	2.90			
2042B16	90.80	5.63	5.126				1	3.10	2042A16	49.00	1.38
2042B17	94.40	5.95	5.442				1	3.40	2042A17	52.40	1.66
2042B18	98.00	6.27	5.759				1	3.56	2042A18	55.60	1.88
2042B19	101.40	6.59	6.076				1	3.72	2042A19	58.20	2.06
2042B20	105.00	6.91	6.392	3/4	2-3/8	3-1/2	1-1/8	4.72	2042A20	59.60	2.40
2042B21	108.60	7.24	6.710					4.84	2042A21	61.40	2.62
2042B22	110.80	7.56	7.027					5.18	2042A22	64.20	2.88
2042B23	114.40	7.88	7.344					5.34	2042A23	65.40	3.14
2042B24	115.60	8.20	7.661					5.58	2042A24	69.40	3.22
2042B25	118.40	8.52	7.979					5.96	2042A25	71.60	3.50
2042B26	123.20	8.84	8.296					6.22	2042A26	79.60	3.74
2042B28	128.20	9.48	8.931					6.78	2042A28	82.80	4.76
2042B30	131.80	10.11	9.567	3/4	2-3/8	3-1/2	1-1/8	7.56	2042A30	87.20	5.08

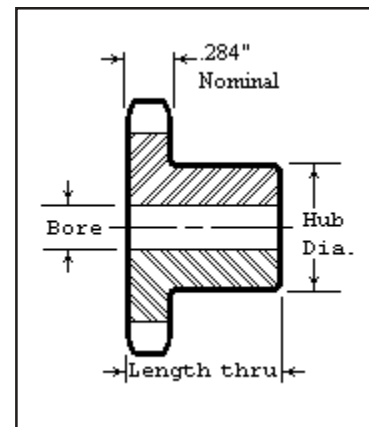



RYLE Manufacturing Company 1-800-433-0960

2050 Extended Pitch 1-1/4" Pitch

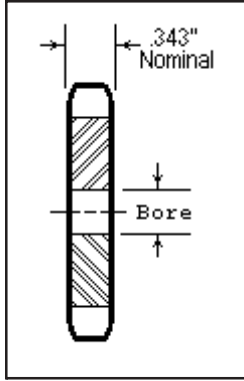

RYLE P/N	LIST PRICE	O.D. TEETH	P.D. TEETH	STOCK BORE	MAX BORE	HUB DIA.	LTB	LBS.	RYLE P/N	LIST PRICE	LBS.
2050B11	39.20	2.50	2.315	5/8	13/16	1-3/4 *	1	.62			
2050B12	41.40	2.71	2.500		1	1-7/8 *	1	.80			
2050B13	43.20	2.91	2.690		1-7/32	1-15/16*	1	.82			
2050B14	45.00	3.11	2.881		1-9/32	2 *	1	1.00			
2050B15	46.20	3.32	3.073		1-7/16	2-1/8	1	1.22			
2050B16	49.80	3.52	3.266		1-19/32	2-5/16	1	1.44			
2050B17	53.80	3.72	3.460		1-3/4	2-9/16	1	1.68			
2050B18	58.20	3.92	3.655		1-25/32	2-3/4	1	1.94			
2050B19	61.80	4.12	3.850		1-31/32	2-7/8	1	2.24			
2050B20	69.40	4.32	4.045		2	3	1	2.30			
2050B21	75.20	4.52	4.241	3/4			1-1/4	2.40	2050A21	47.20	1.2
2050B22	81.00	4.72	4.437					2.54	2050A22	48.00	1.3
2050B23	86.80	4.92	4.633					2.66	2050A23	49.00	1.4
2050B24	93.00	5.12	4.830					3.30	2050A24	49.80	1.6
2050B25	99.20	5.32	5.026					3.42	2050A25	51.20	1.7
2050B26	103.60	5.52	5.223					3.62	2050A26	53.80	1.8
2050B28	106.80	5.92	5.617					3.78	2050A28	57.00	2.1
2050B30	109.40	6.32	6.012					4.58	2050A30	59.60	2.5

* Indicates hub diameter is grooved for chain clearance.

Split Type A plate \$ 2.76
per inch of sprocket diameter

Rebore \$49.00
Keyway \$13.40
Setscrew (each) \$13.40
Harden per tooth \$ 1.02 (2050)
Harden per tooth \$ 2.44 (2052)
Drill Type A plate (4) holes = \$28.00
(6) holes = \$42.00
(8) holes = \$56.00

Maximum bores will accommodate standard keyway and setscrew over key.

Multiple keyways must be priced at factory.

2052 Extended Pitch 1-1/4" Pitch

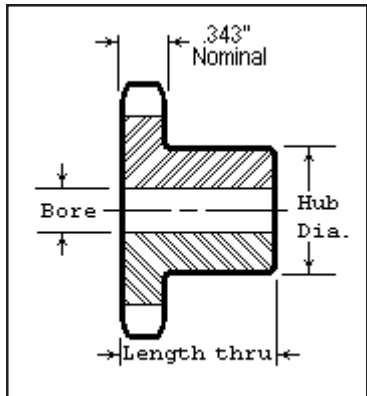

RYLE P/N	LIST PRICE	O.D. TEETH	P.D. TEETH	STOCK BORE	MAX BORE	HUB DIA.	LTB	LBS.	RYLE P/N	LIST PRICE	LBS.
2052B8	50.60	3.77	3.266	5/8	1-19/32	2-23/64	1	1.38			
2052B9	58.80	4.18	3.655		1-25/32	2-25/32	1	1.92			
2052B10	69.40	4.60	4.045		2	3	1	2.30			
2052B11	81.00	5.01	4.437				1	2.54			
2052B12	90.80	5.42	4.830	3/4			1-1/4	3.20	2052A12	50.60	1.6
2052B13	101.80	5.82	5.223					3.48	2052A13	53.80	1.8
2052B14	106.80	6.23	5.617					3.88	2052A14	57.00	2.3
2052B15	109.40	6.63	6.012		2-1/4	3-1/4		4.46	2052A15	59.60	2.4
2052B16	114.40	7.03	6.407					4.80	2052A16	64.20	2.8
2052B17	119.20	7.44	6.803					5.34	2052A17	67.60	3.3
2052B18	122.80	7.84	7.198					5.64	2052A18	70.40	3.6
2052B19	130.00	8.24	7.595					6.04	2052A19	73.80	4.1
2052B20	132.60	8.64	7.991					6.48	2052A20	76.20	4.7
2052B21	136.20	9.04	8.387					7.00	2052A21	78.80	5.0
2052B22	139.60	9.44	8.783					7.30	2052A22	83.60	5.2
2052B23	142.40	9.84	9.180	1	2-3/4	3-3/4		8.66	2052A23	86.80	5.7
2052B24	148.20	10.25	9.577	1				9.32	2052A24	90.80	6.7
2052B25	156.60	10.65	9.973	1				10.30	2052A25	95.60	7.5
2052B26	162.40	11.05	10.370	1				11.00	2052A26	101.00	8.2
2052B28	173.60	11.84	11.164	1				11.70	2052A28	110.80	8.7
2052B30	183.80	12.64	11.958	1				12.90	2052A30	118.40	9.8



RYLE Manufacturing Company 1-800-433-0960

2060 Extended Pitch 1-1/2" Pitch

RYLE P/N	LIST PRICE	O.D. TEETH	P.D. TEETH	STOCK BORE	MAX BORE	HUB DIA.	LTB	LBS.	RYLE P/N	LIST PRICE	LBS.
2060B11	43.20	3.00	2.773	3/4	1	2-1/16*	1-1/4	1.14			
2060B12	46.20	3.25	3.000		1-3/8	2-1/4*		1.46			
2060B13	50.60	3.48	3.228		1-7/16	2-5/16*		1.52			
2060B14	57.00	3.74	3.457		1-5/8	2-1/2*		1.86			
2060B15	62.40	3.96	3.688		1-3/4	2-1/2		2.24			
2060B16	69.40	4.22	3.920		1-7/8	2-3/4		2.64			
2060B17	73.80	4.45	4.152		2-3/32	3-3/32		3.08			
2060B18	85.80	4.70	4.386		2-1/4	3-1/4		3.56			
2060B19	89.40	4.94	4.620				1-1/2	3.94	2060A19	57.60	2.1
2060B20	93.80	5.19	4.854					4.50	2060A20	58.40	2.4
2060B21	98.80	5.42	5.089					5.02	2060A21	60.20	2.5
2060B22	104.20	5.67	5.324					5.26	2060A22	62.00	2.7
2060B23	109.40	5.90	5.560					5.54	2060A23	63.80	3.0
2060B24	118.40	6.15	5.796					5.90	2060A24	65.40	3.2
2060B25	127.60	6.38	6.032					6.08	2060A25	66.80	3.3
2060B26	138.40	6.63	6.268					6.36	2060A26	71.60	3.5
2060B28	142.40	7.11	6.741					7.02	2060A28	75.20	4.0
2060B30	146.00	7.59	7.215					7.54	2060A30	78.80	4.7

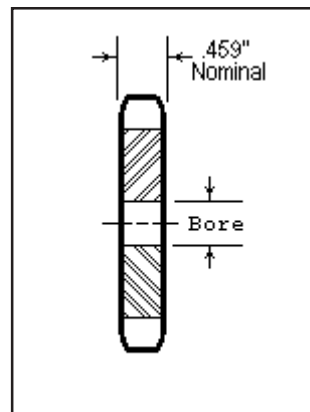

* Indicates hub diameter is grooved for chain clearance.

Maximum bores will accommodate standard keyway and setscrew over key.

Multiple keyways must be priced at factory.

Split Type A plate	\$ 3.42
per inch of sprocket diameter	
Rebore	\$49.00
Keyway	\$13.40
Setscrew (each)	\$13.40
Harden per tooth	\$ 1.56 (2060)
Harden per tooth	\$ 3.06 (2062)
Drill Type A plate	(4) holes = \$28.00
	(6) holes = \$42.00
	(8) holes = \$56.00

2062 Extended Pitch 1-1/2" Pitch

RYLE P/N	LIST PRICE	O.D. TEETH	P.D. TEETH	STOCK BORE	MAX BORE	HUB DIA.	LTB	LBS.	RYLE P/N	LIST PRICE	LBS.
2062B8	70.40	4.52	3.920	3/4	1-27/32	2-27/32	1-1/4	2.6	2062A8	53.80	1.7
2062B9	78.80	5.02	4.386		2-9/32	3-11/32		3.5	2062A10	58.00	2.3
2062B10	95.60	5.52	4.854		2-9/16	3-53/64		4.5	2062A11	63.00	2.5
2062B11	106.80	6.01	5.324		2-3/8	3-1/2		5.2			
2062B12	118.40	6.50	5.796		2-3/4	4	1-1/2	5.7	2062A12	66.20	3.0
2062B13	132.60	6.99	6.268					6.3	2062A13	69.40	3.6
2062B14	138.80	7.47	6.741					6.8	2062A14	73.80	4.0
2062B15	146.00	7.96	7.215					7.5	2062A15	78.80	4.7
2062B16	149.60	8.44	7.689					8.2	2062A16	85.40	5.7
2062B17	154.00	8.92	8.163					8.8	2062A17	90.80	6.1
2062B18	161.60	9.41	8.638					9.4	2062A18	96.60	7.0
2062B19	168.20	9.89	9.113	1		4-1/4		11.1	2062A19	101.40	8.0
2062B20	178.00	10.37	9.589	1				11.7	2062A20	104.40	8.5
2062B21	197.60	10.85	10.064	1				13.2	2062A21	109.40	8.9
2062B22	202.80	11.33	10.540	1				13.8	2062A22	115.60	10.7
2062B23	209.60	11.81	11.016	1				14.9	2062A23	122.80	11.6
2062B24	223.40	12.29	11.492	1				15.7	2062A24	137.60	12.6
2062B25	245.20	12.77	11.968	1				16.8	2062A25	153.20	13.8
2062B26	264.80	13.25	12.444	1				20.2	2062A26	161.60	15.0
2062B28	282.00	14.21	13.397	1				21.9	2062A28	178.40	17.3
2062B30	287.00	15.17	14.350	1				26.0	2062A30	192.20	19.5

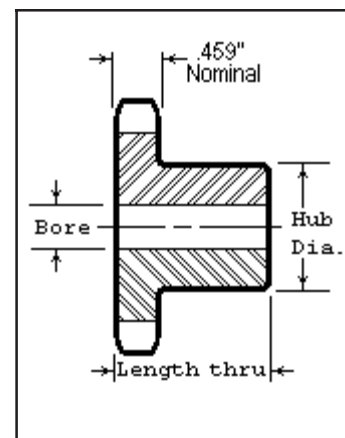



RYLE Manufacturing Company 1-800-433-0960

2080 Extended Pitch 2" Pitch

RYLE P/N	LIST PRICE	O.D. TEETH	P.D. TEETH	STOCK BORE	MAX BORE	HUB DIA.	LTB	LBS.	RYLE P/N	LIST PRICE	LBS.
2080B11	79.00	4.01	3.694	1	1-1/2	2-13/16 *	1-5/8	2.5			
2080B12	85.40	4.33	4.000	1	1-3/4	3-1/8 *		3.2			
2080B13	91.60	4.64	4.304	1	1-7/8	2-25/32	1-1/2	3.3			
2080B14	98.40	4.98	4.610	1	2-1/8	3-1/8		4.0			
2080B15	103.60	5.29	4.917	1	2-3/8	3-7/16		4.8			
2080B16	117.60	5.63	5.226	1	2-1/4	3-1/4		5.7	2080A16	63.80	3.1
2080B17	133.20	5.94	5.536	1				6.4	2080A17	71.80	3.5
2080B18	151.40	6.27	5.848	1				7.4	2080A18	76.20	4.0
2080B19	170.60	6.58	6.160	1	2-3/4	4		7.7	2080A19	80.00	4.4
2080B20	183.80	6.91	6.472	1			1-3/4	8.3	2080A20	85.40	4.7
2080B21	196.80	7.23	6.785	1				8.4	2080A21	88.60	5.1
2080B22	205.00	7.56	7.099	1				10.0	2080A22	93.00	5.6
2080B23	213.60	7.87	7.413	1				10.5	2080A23	98.00	6.2
2080B24	218.00	8.20	7.727	1				11.1	2080A24	102.20	6.6
2080B25	222.80	8.51	8.042	1				12.0	2080A25	106.00	7.0
2080B26	232.00	8.84	8.357	1-1/4	3-1/4	4-3/4	2	14.9	2080A26	112.40	7.9
2080B28	242.00	9.48	8.988					16.6	2080A28	124.00	9.0
2080B30	259.40	10.11	9.620					17.8	2080A30	128.20	10.6

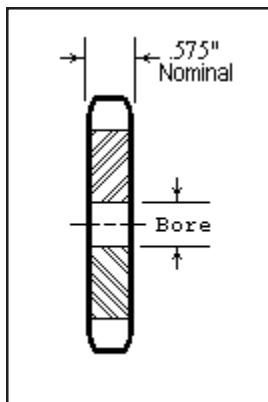

* Indicates hub diameter is grooved for chain clearance.

Split Type A plate \$ 3.42
per inch of sprocket diameter

Rebore \$49.00
Keyway \$13.40
Setscrew (each) \$13.40
Harden per tooth \$ 1.78 (2080)
Harden per tooth \$ 4.36 (2082)
Drill Type A plate (4) holes = \$28.00
(6) holes = \$42.00
(8) holes = \$56.00

Maximum bores will accommodate standard keyway and setscrew over key.

Multiple keyways must be priced at factory.

2082 Extended Pitch 2" Pitch

RYLE P/N	LIST PRICE	O.D. TEETH	P.D. TEETH	STOCK BORE	MAX BORE	HUB DIA.	LTB	LBS.	RYLE P/N	LIST PRICE	LBS.
2082B8	116.60	6.03	5.226	1	2-17/32	3-51/64	1-3/4	6.4			
2082B9	148.00	6.70	5.848	1	2-3/4	4-1/4		8.2			
2082B10	182.80	7.36	6.472	1				9.2	2082A10	88.00	4.8
2082B11	204.40	8.01	7.099	1				10.1	2082A11	94.00	5.7
2082B12	218.00	8.66	7.727	1				11.2	2082A12	101.20	6.8
2082B13	228.60	9.32	8.357	1-1/4	3-1/4	4-3/4	2	15.0	2082A13	108.60	7.7
2082B14	246.40	9.96	8.988					15.8	2082A14	118.60	9.1
2082B15	258.00	10.61	9.620					17.8	2082A15	128.20	10.7
2082B16	277.80	11.26	10.252					19.3	2082A16	143.80	12.4
2082B17	295.60	11.90	10.885					21.4	2082A17	155.20	14.1
2082B18	315.80	12.54	11.518					22.9	2082A18	164.80	15.4
2082B19	341.40	13.19	12.151					24.4	2082A19	189.00	18.0
2082B20	350.00	13.83	12.785					26.7	2082A20	197.60	19.2
2082B21	355.40	14.47	13.419					28.4	2082A21	205.00	20.8
2082B22	393.00	15.11	14.053					29.6	2082A22	242.00	23.7
2082B23	409.80	15.75	14.688					32.2	2082A23	276.20	24.9
2082B24	435.80	16.39	15.323					34.9	2082A24	313.80	27.6
2082B25	473.40	17.03	15.958					37.8	2082A25	345.20	30.2
2082B26	493.20	17.67	16.593		3-1/2	5-1/4		41.5	2082A26	371.20	32.8
2082B28	552.00	18.95	17.863					47.7	2082A28	390.60	38.6
2082B30	601.60	20.23	19.134					54.5	2082A30	425.80	43.8

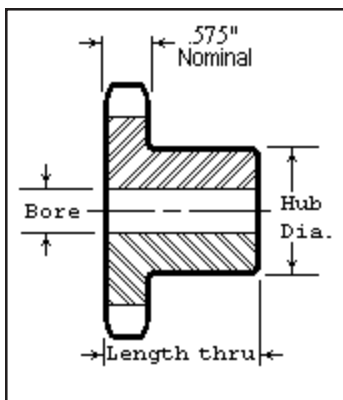



RYLE Manufacturing Company 1-800-433-0960

No. 2100 Extended Pitch 2-1/2" Pitch

2100 (3/4" Roller)

RYLE P/N	LIST PRICE	O.D. TEETH	P.D. TEETH	STOCK BORE	LBS.
2100A15	92.20	6.61	6.146	1-1/4	5.9
2100A16	102.60	7.03	6.532		6.8
2100A17	105.40	7.42	6.920		7.8
2100A18	120.60	7.84	7.310		8.4
2100A19	130.60	8.23	7.700		9.5
2100A20	135.00	8.64	8.090		10.1
2100A21	145.20	9.03	8.481		11.0
2100A22	160.80	9.44	8.872		12.6
2100A23	172.00	9.84	9.266		13.2
2100A24	185.00	10.25	9.660		14.6
2100A25	189.00	10.64	10.053		15.3
2100A30	246.50	12.64	12.025	1-1/4	22.0

2102 (1-9/16" Roller)

RYLE P/N	LIST PRICE	O.D. TEETH	P.D. TEETH	STOCK BORE	LBS.
2102A10	216.50	9.19	8.090	1-1/2	8
2102A11	231.90	10.02	8.872		12
2102A12	270.70	10.83	9.660		14
2102A13	286.20	11.64	10.447		16
2102A14	309.30	12.45	11.235		19
2102A15	355.90	13.26	12.025		22
2102A16	394.40	14.07	12.815		25
2102A17	429.10	14.87	13.605		28
2102A18	456.10	15.67	14.397		31
2102A19	479.50	16.48	15.190		35
2102A20	502.70	17.28	15.982		39
2102A25	812.00	21.29	19.947	1-1/2	60

Split Type A plate \$ 3.78
per inch of sprocket diameter

Rebore \$49.00
Keyway \$13.40
Setscrew (each) \$13.40
Harden per tooth \$ 2.44 (2100)
Harden per tooth \$ 5.32 (2102)
Drill Type A plate (4) holes = \$28.00
(6) holes = \$42.00
(8) holes = \$56.00

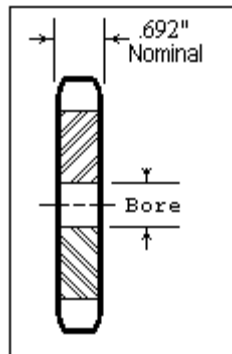

Single Duty sprockets available on Made To Order basis only
see Ryle Catalog page 94



RYLE Manufacturing Company 1-800-433-0960

No. 2120 Extended Pitch 3" Pitch

2120 (7/8" Roller)

RYLE P/N	LIST PRICE	O.D. TEETH	P.D. TEETH	STOCK BORE	LBS.
2120A15	212.50	7.93	7.376	1-1/2	10.0
2120A16	216.00	8.44	7.839		11.5
2120A17	228.50	8.91	8.304		13.1
2120A18	243.50	9.41	8.772		14.6
2120A19	275.00	9.88	9.240		16.2
2120A20	290.00	10.37	9.708		18.0
2120A21	295.60	10.84	10.178		20.5
2120A22	305.20	11.33	10.649		23.1
2120A23	324.30	11.80	11.120		25.6
2120A24	341.40	12.29	11.591		27.7
2120A25	352.80	12.77	12.063		29.8
2120A30	483.20	15.17	14.430	1-1/2	42.5

2122 (1-3/4" Roller)

RYLE P/N	LIST PRICE	O.D. TEETH	P.D. TEETH	STOCK BORE	LBS.
2122A10	339.90	11.03	9.708	1-1/2	15
2122A11	374.40	12.02	10.648		18
2122A12	411.80	13.00	11.591		21
2122A13	452.10	13.97	12.536		24
2122A14	492.30	14.95	13.482		29
2122A15	536.70	15.92	14.429		33
2122A16	588.00	16.88	15.377	1-1/2	37
2122A17	639.30	17.85	16.328	2	42
2122A18	701.80	18.81	17.276		47
2122A19	764.20	19.78	18.227		5
2122A20	826.40	20.74	19.177		58
2122A25	1142.20	25.55	23.936	2	91

Split Type A plate \$ 4.08
per inch of sprocket diameter

Rebore \$49.00
Keyway \$13.40
Setscrew (each) \$13.40
Harden per tooth \$ 3.06 (2120)
Harden per tooth \$ 6.40 (2122)
Drill Type A plate (4) holes = \$28.00
(6) holes = \$42.00
(8) holes = \$56.00

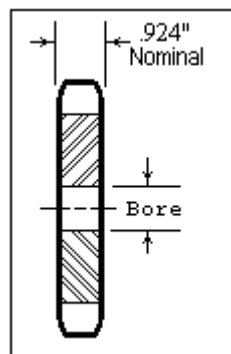

Single Duty sprockets available on Made To Order basis only
see Ryle Catalog page 94



FLAME CUT SPROCKETS FOR CHAINS:

62 - 062 - 2 - 62A - HF62A - 62H - H62 - 072 - 72-1/2 - 162 - R362 - RR362 - R432
RR432 - 962 - LXS627 - IS620 - 162R - US622 - 378R - 402RX - US620 - 362 - R2362

1.654" CHAIN PITCH 13/16" ROLLER OR BARREL DIAMETER 11/16" FACE THICKNESS

62

NO. TEETH	RYLE P/N	LIST PRICE	PITCH DIA	STOCK BORE	MAX BORE	HUB DIA.	LTB	LBS.	RYLE P/N	LIST PRICE	LBS
10	62C10	130.30	5.35	1	2-1/4	3-1/4	2-1/2	13	62A10	59.80	5
12	62C12	154.00	6.39	1	2-3/4	4-1/4	3	16	62A12	69.40	7
13	62C13	178.20	6.91	1	3-1/4	4-3/4		19	62A13	79.00	8
14	62C14	188.60	7.43	1				21	62A14	89.60	9
15	62C15	199.20	7.96	1				22	62A15	100.40	11
17	62C17	223.80	9.00	1				24	62A17	124.80	14
19	62C19	250.40	10.05	1				28	62A19	151.40	17
20	62C20	278.60	10.57	1				30	62A20	165.80	19
24	62C24	429.20	12.67	1-1/4	3-3/4	5-1/2	4-3/8	49	62A24	230.00	26
26	62C26	465.20	13.72					53	62A26	266.00	30
30	62C30	545.20	15.72					65	62A30	345.80	42
36	62C36	684.80	18.98					82	62A36	485.60	59
54	62C54	1245.20	28.45					125	62A54	1046.00	135
60	62C60	1480.20	31.60					138	62A60	1281.00	169

Driver style tooth form. Maximum Bore allows for standard keyway and setscrew(s).

Split Type A plate	\$ 4.80 (62)
	\$ 5.60 (78)
per inch of sprocket pitch diameter	
Rebore	\$70.00
Keyway	\$20.00
Setscrew (each)	\$20.00
Harden per tooth	\$ 4.36 (62 chain)
Harden per tooth	\$ 5.60 (78 chain)

Drill Type A plate	(4) holes	\$40.00
	(6) holes	\$60.00
	(8) holes	\$80.00



FLAME CUT SPROCKETS FOR CHAINS:

78 - 87R - 88 - 188 - 433-1/2 - 488 - 588R - 988 - IS880 - IS881 - LXS882
74 - H74 - 75 - H75 - H78RT - H78SR - H79 - S188 - S78 - R588 - R778 - 988
IS880 - 87R - IS881 - 81X - IS882 - LXS881 - LXS886 - US881 - LXS887 - C188
XS578 - SS188 - US278R - US278 - US882 - 578R - 588R

2.609" PITCH 7/8" ROLLER OR BARREL DIAMETER 7/8" PLATE THICKNESS

78

NO. TEETH	RYLE P/N	LIST PRICE	PITCH DIA.	STOCK BORE	MAX BORE	HUB DIA.	LTB	LBS.	RYLE P/N	LIST PRICE	LBS.
8	78C8	188.40	6.82	1	2-3/4	4-1/4	3	21	78A8	93.00	9
9	78C9	265.80	7.63	1-1/4	3-7/16	5-1/4	3-7/8	29	78C9	112.40	11
10	78C10	286.80	8.44					31	78A10	133.40	14
11	78C11	310.00	9.26					34	78A11	156.60	17
12	78C12	335.20	10.08					37	78A12	181.80	20
13	78C13	408.40	10.90		3-3/4	5-1/2	4-1/2	46	78A13	209.20	23
14	78C14	437.20	11.72					49	78A14	238.00	27
15	78C15	468.20	12.55	1-1/2				53	78A15	269.00	30
16	78C16	501.80	13.37					57	78A16	316.40	34
17	78C17	535.40	14.20					62	78A17	336.20	39
19	78C19	751.00	15.85		4-1/2	6-1/2	5-3/8	90	78A19	410.40	50
21	78C21	834.80	17.51					101	78A21	494.20	61
24	78C24	972.20	19.99					119	78A24	631.60	79
25	78C25	1023.00	20.82					124	78A25	682.40	84
28	78C28	1184.60	23.31					132	78A28	844.00	105
30	78C30	1301.00	24.96					150	78A30	960.20	123
35	78C35	1627.60	29.11					170	78A35	1287.00	166
40	78C40	2207.40	33.25		4-15/16	7-1/4	6-3/4	226	78A40	1661.60	216
42	78C42	2370.80	34.91					240	78A42	1824.80	240
46	78C46	2717.40	38.31					325	78A46	2171.60	286
54	78C54	2821.00	44.87					368	78A54	2275.20	302
60	78C60	4181.80	49.85					388	78A60	3635.80	322

Conveyor style tooth form. Maximum bore allows for standard keyway and setscrew(s)



1568

FLAME CUT SPROCKETS FOR CHAINS:

LXS3011 - US3011 - IS3011 - MXS3011 - 1803A - 1803AB - XX5568 - SS568 - JS3011 - 3011 - LXS3011M

3.067" CHAIN PITCH

1-5/8" ROLLER OR BARREL DIAMETER

1-3/8" PLATE THICKNESS

NO. TEETH	RYLE P/N	LIST PRICE	PITCH DIA.	STOCK BORE	MAX BORE	HUB DIA.	LTB	LBS.	RYLE P/N	LIST PRICE	LBS.
10	1568C10	456.60	9.92	1-1/2	3-3/4	5-1/2	4-1/4	46	1568A10	287.20	28
12	1568C12	554.80	11.85					58	1568A12	385.60	40
14	1568C14	641.40	13.78					73	1568A14	472.20	53
30	1568C30	2287.20	29.34		4-1/2	6-1/2	5-3/4	240	1568A30	1946.40	217
36	1568C36	3225.40	35.19		5-3/8	7-1/2	5-7/8	290	1568A36	2755.20	257
42	1568C42	4245.60	41.04		5-1/2	8	6-1/8	407	1568A42	3681.80	340
48	1568C48	5305.40	46.89					448	1568A48	4741.60	381

Driver Style tooth form. Maximum bore allows for standard keyway and setscrew(s).

Split Type A plate \$ 8.00 (1568 & 1030)
per inch of sprocket pitch diameter

Rebore \$70.00
Keyway \$20.00
Setscrew (each) \$20.00
Harden per tooth \$ 7.20 (1568 & 1030)

Drill Type A plate (4) holes \$40.00
(6) holes \$60.00
(8) holes \$80.00

FLAME CUT SPROCKETS FOR CHAINS:

1030 - 1037 - 1190R - 1539 - API-3 - CHAMPION NO.3 - IS-1031 - LXS-1032 - R-1033
R-1035 - SS-40 - IS1037 - US1031 - 1190 - 1190R - US1032 - SXX - 4103 - 103

3.075" CHAIN PITCH

1-1/4" ROLLER DIAMETER

1-1/8" PLATE THICKNESS

NO. TEETH	RYLE P/N	LIST PRICE	PITCH DIA.	STOCK BORE	MAX BORE	HUB DIA.	LTB	LBS.	RYLE P/N	LIST PRICE	LBS.
8	1030C8	314.40	8.05	1-1/4	3-1/4	5	3-7/8	31	1030A8	189.40	18
9	1030C9	353.40	8.99					36	1030A9	228.20	22
10	1030C10	396.00	9.95					40	1030A10	271.00	28
11	1030C11	486.80	10.91	1-1/2	3-3/4	5-1/2	4-1/4	51	1030A11	317.40	33
12	1030C12	537.20	11.88					57	1030A12	367.80	39
13	1030C13	591.40	12.85					64	1030A13	422.00	46
15	1030C15	794.80	14.79		4	6	5-1/8	91	1030A15	541.80	60
17	1030C17	929.40	16.73					109	1030A17	676.40	78
19	1030C19	1165.60	18.68		4-1/2	6-1/2	5-3/4	137	1030A19	824.80	97
21	1030C21	1332.80	20.63					158	1030A21	992.20	118
24	1030C24	1607.80	23.56					176	1030A24	1267.00	154
25	1030C25	1836.80	24.53		5-3/8	7-1/2	5-7/8	206	1030A25	1366.60	167
28	1030C28	2159.60	27.46					236	1030A28	1689.40	210
30	1030C30	2392.80	29.42					254	1030A30	1922.60	240
35	1030C35	3133.80	34.30		5-1/2	8	6-1/8	327	1030A35	2570.00	313
40	1030C40	3881.00	39.19					427	1030A40	3317.20	360
42	1030C42	4209.60	41.15					450	1030A42	3645.80	380
48	1030C48	5680.00	47.03		6-1/2	9-1/2	6-3/4	501	1030A48	4707.60	400
54	1030C54	6871.20	52.89					549	1030A54	5899.00	432
60	1030C60	8562.80	58.75		7	10	7-1/2	642	1030A60	7247.80	506

Driver Style tooth form. Maximum bore allows for standard keyway and setscrew(s).



1030



82

FLAME CUT SPROCKETS FOR CHAINS:

103 - 131 - 382 - 527R - 4103 - 6131 - C-9103 - H82

3.075" CHAIN PITCH

1-7/32" ROLLER OR BARREL DIAMETER

1-1/8" PLATE THICKNESS

NO. TEETH	RYLE P/N	LIST PRICE	PITCH DIA	STOCK BORE	MAX BORE	HUB DIA.	LTB	LBS.	RYLE P/N	LIST PRICE	LBS.
7	82C7	264.20	7.09	1	2-15/16	4-1/2	3-7/8	24	82A7	138.20	19
8	82C8	332.80	8.04	1-1/4	3-3/4	5-1/4	4-1/8	34	82A8	169.40	16
9	82C9	356.60	8.99					38	82A9	203.20	20
10	82C10	441.80	9.95					43	82A10	242.60	25
11	82C11	483.40	10.91		3-15/16	5-3/4	4-3/8	54	82A11	284.20	30
12	82C12	528.60	11.88					60	82A12	329.40	36
13	82C13	577.80	12.85					66	82A13	378.60	42
14	82C14	771.00	13.82					72	82A14	430.40	48
15	82C15	824.80	14.79	1-1/2	4-1/2	6-1/2	5-5/8	94	82A15	484.20	54
16	82C16	888.60	15.76					102	82A16	548.00	62
17	82C17	946.40	16.73					110	82A17	605.60	70
18	82C18	1012.00	17.71					119	82A18	671.40	79

Conveyor style tooth form. Maximum Bore allows for standard keyway and setscrew(s).

Split Type A plate	\$ 8.00 (82 & 238)
per inch of sprocket pitch diameter	
Rebore	\$70.00
Keyway	\$20.00
Setscrew (each)	\$20.00
Harden per tooth	\$ 7.20 (82 & 238 chain)

Drill Type A plate	(4) holes	\$40.00
	(6) holes	\$60.00
	(8) holes	\$80.00



238

FLAME CUT SPROCKETS FOR CHAINS:

1616A - IS3514 - RX238 - 1616A - MXS3514 - US3514 - LXS3514

3.500" CHAIN PITCH

1-3/4" ROLLER OR BARREL DIAMETER

1-3/8" PLATE THICKNESS

NO. TEETH	RYLE P/N	LIST PRICE	PITCH DIA.	STOCK BORE	MAX BORE	HUB DIA.	LTB	LBS.	RYLE P/N	LIST PRICE	LBS.
10	238C10	534.40	11.33	1-1/2	3-3/4	5-1/2	4-1/4	54	238A10	365.00	35
12	238C12	661.80	13.52					70	238A12	492.40	51
14	238C14	808.80	15.73					88	238A14	639.60	60
30	238C30	2781.20	33.48		4	6	5-1/8	312	238A30	2528.20	253
36	238C36	3813.20	40.16					445	238A36	3560.20	370
42	238C42	5140.00	46.84		5-1/2	8	6-1/8	456	238A42	4761.40	379
48	238C48	6508.60	53.52					517	238A48	6130.20	450

Driver Style tooth form. Maximum Bore allows for standard keyway and setscrew(s).



124

FLAME CUT SPROCKETS FOR CHAINS:

W124 - WH124 - WS124 - H124

4.000" CHAIN PITCH

1-1/2" ROLLER OR BARREL DIAMETER

1-3/8" PLATE THICKNESS

NO. TEETH	RYLE P/N	LIST PRICE	PITCH DIA.	STOCK BORE	MAX BORE	HUB DIA.	LTB	LBS.	RYLE P/N	LIST PRICE	LBS
6	124C6	332.00	8.00	1	3-1/4	4-3/4	4-5/8	36	124A6	234.40	21
7	124C7	495.00	9.22	1	3-15/16	5-3/4	4-3/4	52	124A7	235.80	28
8	124C8	563.80	10.15	1				61	124A8	364.60	37
9	124C9	640.60	11.70	1				70	124A9	441.40	46
10	124C10	725.20	12.94	1				79	124A10	526.00	55
11	124C11	852.80	14.20	1-1/2	4-1/4	6-1/4	4-3/4	95	124A11	617.60	68
12	124C12	952.40	15.45					107	124A12	717.20	80
13	124C13	1061.80	16.72					120	124A13	826.80	93
14	124C14	1177.40	17.98					135	124A14	942.40	108
15	124C15	1436.40	19.24		4-3/8	6-3/4	6	168	124A15	1065.80	124
16	124C16	1565.80	20.50					185	124A16	1195.40	141

Conveyor style tooth form. Maximum Bore allows for standard keyway and setscrew(s).

Split Type A plate \$12.00 (124 & 1240)
per inch of sprocket pitch diameter

Rebore \$70.00
Keyway \$20.00
Setscrew (each) \$20.00
Harden per tooth \$ 8.00 (124 & 1240)

Drill Type A plate (4) holes \$40.00
(6) holes \$60.00
(8) holes \$80.00



1240

FLAME CUT SPROCKETS FOR CHAINS:

1240RX - 1244 - IS1425 - R1248 - RX1245 - SS124 - API-4 - 3 BARHYPER

4.063" CHAIN PITCH

1-3/4" ROLLER OR BARREL DIAMETER

1-3/4" PLATE THICKNESS

NO. TEETH	RYLE P/N	LIST PRICE	PITCH DIA.	STOCK BORE	MAX BORE	HUB DIA.	LTB	LBS.	RYLE P/N	LIST PRICE	LBS.
6	1240C6	381.80	8.13	1	2-1/2	4	4	34	1240A6	298.80	26
7	1240C7	527.20	9.36	1-1/4	3-3/4	5-1/4	4-3/4	51	1240A7	373.80	34
8	1240C8	739.20	10.62	1-1/2	4-1/2	6-1/2	5	78	1240A8	458.20	44
9	1240C9	832.80	11.88					89	1240A9	553.20	55
10	1240C10	938.40	13.15					101	1240A10	657.40	67
11	1240C11	1052.00	14.42					115	1240A11	771.00	81
12	1240C12	1213.20	15.70		5-1/4	7	6	140	1240A12	834.80	96
13	1240C13	1402.60	16.98					155	1240A13	1024.00	111
14	1240C14	1544.00	18.26					174	1240A14	1165.60	130
15	1240C15	1693.40	19.54					192	1240A15	1314.80	148
16	1240C16	2000.20	20.83		5-1/2	8	6-1/4	230	1240A16	1476.20	168
18	1240C18	2346.80	23.40					275	1240A18	1823.00	213
20	1240C20	2731.40	25.97					300	1240A20	2207.40	263
21	1240C21	2936.60	27.26					319	1240A21	2412.60	289
24	1240C24	3612.00	31.12					387	1240A24	3088.00	370
25	1240C25	4060.20	33.42		6	9		426	1240A25	3331.00	409
28	1240C28	4833.20	36.29					494	1240A28	4104.00	480
30	1240C30	5759.60	38.87		7	10	6-3/4	583	1240A30	4685.80	561
35	1240C35	7339.40	45.33					729	1240A35	6265.60	620
40	1240C40	9929.40	51.78					932	1240A40	8078.60	721
48	1240C48	13322.20	62.12					1078	1240A48	11471.40	867

Driver Style tooth form. Maximum Bore allows for standard keyway and setscrew(s).



FLAME CUT SPROCKETS FOR CHAINS:

450-SXX - 1340RX - 1350 - IS4522 - RO635 - MXS4522 - B635 - X635

635

4.500" CHAIN PITCH

2-1/4" ROLLER OR BARREL DIAMETER

1-3/4" PLATE THICKNESS

NO. TEETH	RYLE P/N	LIST PRICE	PITCH DIA.	STOCK BORE	MAX BORE	HUB DIA.	LTB	LBS.	RYLE P/N	LIST PRICE	LBS.
10	635C10	1028.00	14.56	1-1/2	4	6-1/2	5	111	635A10	828.80	87
12	635C12	1322.80	17.39					148	635A12	1123.60	119
14	635C14	3592.00	20.22					188	635A14	3392.80	159
30	635C30	6225.80	43.05		5-3/8	7-1/2	5-7/8	592	635A30	5801.40	542
36	635C36	8616.60	51.63					764	635A36	8192.00	715
42	635C42	11961.40	60.22		6-1/2	9-1/2	7-1/4	884	635A42	10989.20	776
48	635C48	16039.60	68.81		6-3/4	10	7-3/4	1174	635A48	14188.80	963

Driver Style tooth form. Maximum Bore allows for standard keyway and setscrew(s).

Split Type A plate	\$12.00
per inch of sprocket pitch diameter	
Harden per tooth	\$ 8.00
Rebore	\$70.00
Keyway	\$20.00
Setscrew (each)	\$20.00

Drill Type A plate	(4) holes	\$40.00
	(6) holes	\$60.00
	(8) holes	\$80.00



FLAME CUT SPROCKETS FOR CHAINS:

1510XXX - 1602A - 1602AA - A1302 - JS5031 - 5035 - 5031 - LXS6038M - A1302
MXS5028 - RO1205 - RX1207 - US5021 - LXS5028 - LXS6038

1207

5.000" CHAIN PITCH

2-1/2" ROLLER OR BARREL DIAMETER

2-1/4" PLATE THICKNESS

NO. TEETH	RYLE P/N	LIST PRICE	PITCH DIA.	STOCK BORE	MAX BORE	HUB DIA.	LTB	LBS.	RYLE P/N	LIST PRICE	LBS.
10	1207C10	1565.80	16.18	1-1/2	4-1/2	6-1/2	5-1/2	160	1207A10	1311.00	131
12	1207C12	2028.20	19.32					215	1207A12	1773.20	187
14	1207C14	2691.60	22.47		5-3/8	7-1/2	5-7/8	298	1207A14	2313.00	254
30	1207C30	9925.40	47.84		6	9	6-3/4	809	1207A30	9196.20	730
36	1207C36	14288.40	57.37		6-3/4	10	8-1/2	1161	1207A36	12973.40	1025
42	1207C42	18723.20	66.91					1245	1207A42	17408.20	1109

Driver Style tooth form. Maximum Bore allows for standard keyway and setscrew(s).

Split Type A plate	\$16.00
per inch of sprocket pitch diameter	
Harden per tooth	\$10.00
Rebore	\$70.00
Keyway	\$20.00
Setscrew (each)	\$20.00

Drill Type A plate	(4) holes	\$40.00
	(6) holes	\$60.00
	(8) holes	\$80.00



FLAME CUT SPROCKETS FOR CHAINS:

132 - 6150P - SA150 - W157 - A132 - C132 - WS132 SX150 - SXA150 - 150X - 6150 - WH157 - WR157

132

6.050" CHAIN PITCH

1-23/32" ROLLER OR BARREL DIAMETER

2-3/4" PLATE THICKNESS

NO. TEETH	RYLE P/N	LIST PRICE	PITCH DIA.	STOCK BORE	MAX BORE	HUB DIA.	LTB	LBS.	RYLE P/N	LIST PRICE	LBS.
6	132C6	1151.60	12.10	1-1/2	4-1/2	6-1/2	6	119	132A6	896.60	90
7	132C7	1396.60	13.95					149	132A7	1141.60	120
8	132C8	1675.60	15.81					182	132A8	1420.40	153
9	132C9	2109.80	17.69		5-3/8	7-1/2	6-3/8	236	132A9	1731.20	192
10	132C10	2440.60	19.58					278	132A10	2062.00	235
11	132C11	2829.00	21.47					326	132A11	2450.40	283
12	132C12	3237.40	23.38					378	132A12	2859.00	334

Conveyor Style tooth form. Maximum Bore allows for standard keyway and setscrew(s).

Split Type A plate	\$20.00
per inch of sprocket pitch diameter	
Harden per tooth	\$12.00
Rebore	\$70.00
Keyway	\$20.00
Setscrew (each)	\$20.00

Drill Type A plate	(4) holes	\$40.00
	(6) holes	\$60.00
	(8) holes	\$80.00



458

FLAME CUT SPROCKETS FOR CHAINS:

458 X458

4.031" CHAIN PITCH

NO ROLLER OR BARREL

7/8" PLATE THICKNESS

NO. TEETH	RYLE P/N	LIST PRICE	PITCH DIA.	STOCK BORE	MAX BORE	HUB DIA.	LTB	LBS.	RYLE P/N	LIST PRICE	STOCK BORE	LBS.
5	458C5	1460.00	13.045	1-1/2	2-15/16	4-1/2	3-7/8	28	458A5	1240.00	1-1/2	20
6	458C6	1700.00	15.576		3-1/2	5-1/4		36	458A6	1445.00		28
7	458C7	2170.00	18.116		4	5-3/4		48	458A7	1844.50		35
8	458C8	2730.00	20.664		4-1/2	6-1/2	4-1/8	98	458A8	2320.50		85
9	458C9	3375.90	23.215	1-1/2	4-1/2	6-1/2		120	458A9	2870.50		100

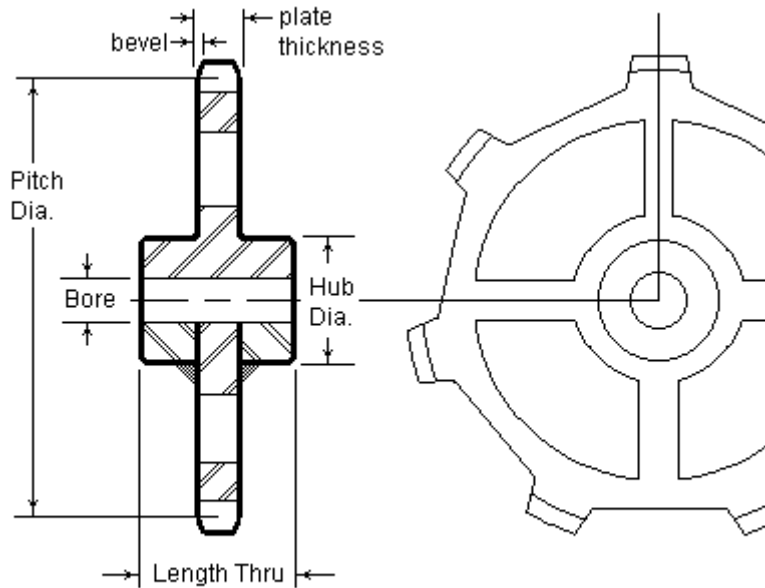

458 and 678 series - all spoke wheel design

FLAME CUT SPROCKETS FOR CHAINS

678 X678

6.031" CHAIN PITCH

NO ROLLER OR BARREL

1-1/8" PLATE THICKNESS



678

NO. TEETH	RYLE P/N	LIST PRICE	PITCH DIA.	STOCK BORE	MAX BORE	HUB DIA.	LTB	LBS	RYLE P/N	LIST PRICE	LBS
5	678C5	1875.00	19.518	2	3-15/16	5-3/4	4-1/4	65	678A5	1630.25	60
6	678C6	2250.00	23.303		4-1/2	6-1/2		125	678A6	1957.50	80
7	678C7	2887.50	27.104		5-1/2	8	5-1/2	150	678A7	2510.20	110
8	678C8	3630.00	30.915					210	678A8	3158.10	160
9	678C9	4390.00	34.733	2	5-1/2	8	5-1/2	248	678A9	3820.30	205

RYLE Manufacturing Company 1-800-433-0960

Tooth Profiles for Extended Pitch & Flame Cut

Standard Rollers
Double Duty

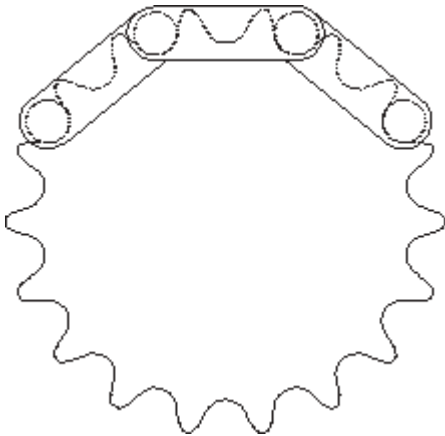

Standard Rollers
Single Duty

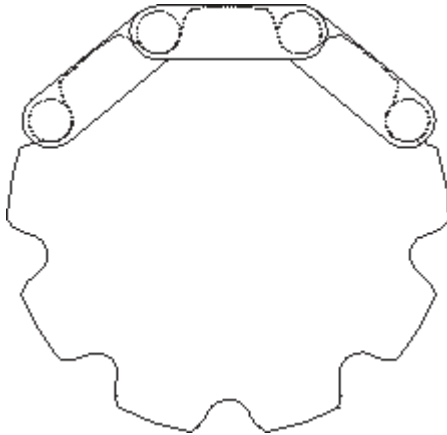

Oversize Rollers
Single Duty

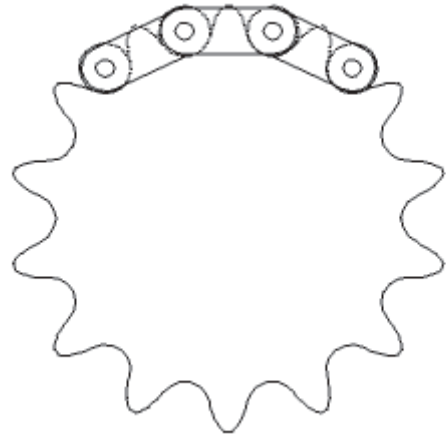

Catalog Item for Chains:

Made
To
Order

Catalog Item for Chains:

2040, 2050, 2060,
2080, 2100, 2120

2042, 2052, 2062,
2082, 2102, 2122



Driver Style

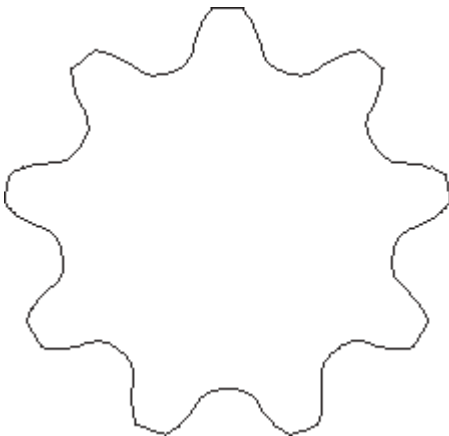

Conveyor Style

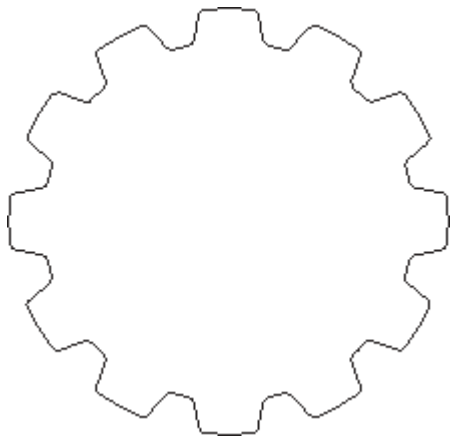

Flame Cut Sprockets
for Chains:

62, 1568, 1030,
238, 1240,
635, 1207

Flame Cut Sprockets
for Chains:

78, 82
124, 132

