



Ryle Manufacturing Companysince 1948



Type A



Type B



Type BS



Type D Double



Type DS Double Single



Type E Triple



Type F Quadruple



Type C web



Type QD



Extended Pitch



Stainless Steel



Flame Cut



Quintuple



Large QD

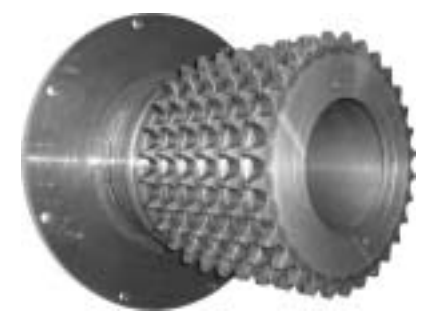

Oil Field

Ryle Manufacturing Company

3116 Holliday Road (76302)

P O Box 5347

Wichita Falls, TX 76307-5347

Phone: 1-800-433-0960

Fax: 940-767-4849

www.rylesprocket.com



INDEX	2
CONDITIONS OF SALE & RETURN POLICY	3-4
ENGINEERING	5-8
WELD-ON QD ADAPTERS & QD BUSHINGS	9-10

MACHINE CUT TEETH SPROCKETS FOR AMERICAN STANDARD ROLLER CHAINS:

A.S.A. CHAIN NO.	25 (1/4" pitch)	11-12
	35 (3/8" pitch)	13-17
	41 (1/2" pitch)	18-19
	40 (1/2" pitch)	20-28
	50 (5/8" pitch)	29-37
	60 (3/4" pitch)	38-47
	80 (1" pitch)	48-54
	100 (1-1/4" pitch)	55-60
	120 (1-1/2" pitch)	61-65
	140 (1-3/4" pitch)	66-69
	160 (2" pitch)	70-73
	180 (2-1/4" pitch)	74-75
	200 (2-1/2" pitch)	76-78
	240 (3" pitch)	79
	SPLIT SPROCKETS	80
	COUPLING HALVES	81-82
	DOUBLE PITCH	83-88

FLAME CUT TEETH SPROCKETS FOR ENGINEERED CLASS CHAINS:

CHAIN NUMBER	62 (1.654" pitch)	89
	78 (2.609" pitch)	89
	1568 (3.067" pitch)	90
	1030 (3.075" pitch)	90
	82 (3.075" pitch)	91
	238 (3.500" pitch)	91
	124 (4.000" pitch)	92
	1240 (4.063" pitch)	92
	635 (4.500" pitch)	93
	1207 (5.000" pitch)	93
	132 (6.050" pitch)	93



RYLE Manufacturing Company 1-800-433-0960

Conditions of Sale

CONDITIONS OF SALE

of Ryle Manufacturing Company, hereinafter called "the company" are as follows in order to give the company and the purchaser a clear understanding. No additional or different terms and conditions shall be binding on the company unless expressly consented to by the company in writing. The acceptance by the company of an order from the purchaser is expressly conditioned on the purchaser's agreement to said conditions of sale. The acceptance of acknowledgement, whether written, oral, by conduct, or otherwise, by the company of purchaser's order shall not constitute written consent by the company to any condition to or change in said condition of sale.

WARRANTY

is limited to the original user and we warrant the products we manufacture to be free of defects in material and workmanship, of good saleable quality, and possessing the characteristics set forth in this warranty. The company is not liable for consequential damages (loss of profit, delays, etc.) whether based on contract or other. CLAIMS for defects in material and workmanship must be made within twelve (12) months from date of shipment. When satisfactory proof of claim has been duly received by the company at the factory, we will make necessary corrections or, at our option, replace defective parts free of charge F.O.B. factory upon receipt of defective parts freight prepaid to factory. IN LIEU OF ANY OTHER WARRANTY(S), EXPRESSED OR IMPLIED INCLUDING ANY WARRANT(S) WHICH MIGHT EXTEND BEYOND THE PRODUCT DESCRIPTION, THIS IS OUR FULL WARRANTY.

SHIPPING DATES

will be made on or before quoted times except for delays caused by circumstances beyond our control which delays we accept no liability for. Our liability ceases upon delivery to the carrier.

ROUTING

will be shipped cheapest and fastest as best we can determine these variables when the customer has not specified routing with the order. In the event we choose a higher cost routing or a slower delivery routing on an order that the customer has not specified the routing, we accept no liability for added expense or extra slow delay in receiving. We suggest that customers specify routing and in lieu of such specification we will make the best choice we can to ship the cheapest and fastest.

CANCELLATION

must be accepted by the company in writing. Cancellation will be accepted only on terms indemnifying us against loss.

OVERRUNS AND SHORTAGES

on made-to-order (MTO) and special order sprockets will occur on most orders because more than the required number must be made to offset normal manufacturing losses. Therefore orders for specials and made-to-order non-catalog items will be accepted, shipped, and invoiced only on the basis of plus or minus five percent (5%) of the quantity ordered. In the event of a 5% shortage in shipment, this shortage will be subsequently manufactured only on the basis of our accepting a new order to produce such parts. Orders for specials and made-to-order non-catalog items will be accepted only on the basis that customer will accept as complete shipment plus or minus 5% of the quantity ordered.

TAXES

such as sales, use, consumer, etc., applicable to the sale, use, or purchase of any item shipped is not included in catalog or quoted prices and will be paid by the buyer.



RYLE Manufacturing Company 1-800-433-0960

Return Policy

RYLE MANUFACTURED PRODUCTS only will be accepted back into our stock. Products of other manufacturers are unacceptable.

ACCEPTANCE must be in writing from the factory.

PRODUCTS MUST BE RETURNED TO FACTORY ONLY. Products will not be accepted by any non-factory location such as warehouses.

FREIGHT must be prepaid to Wichita Falls, Texas.

INSPECTION of returned goods will be made at factory at time of arrival. Unsalable parts as determined by this inspection will be cause for rejection.

ALTERATIONS, DAMAGES, OR CHANGES of any kind to the original product as revealed by inspection will be cause for rejection.

SPECIALS AND ALTERED PRODUCTS will not be accepted. Products must be as listed in RYLE catalog.

LARGE QUANTITY of stock catalog items will be subject to negotiation for acceptance if the quantity is of such size as to be larger than that normally carried in factory stock.

CATALOG ITEMS offered for return, but which is not normally carried in stock at the factory will be cause for rejection.

A RESTOCKING CHARGE of twenty percent (20%) will be made based on the net invoice cost as shown on the RYLE invoice furnished by the customer. This charge will be in addition to any reworking charges accepted by the customer.



Tooth Dimensions

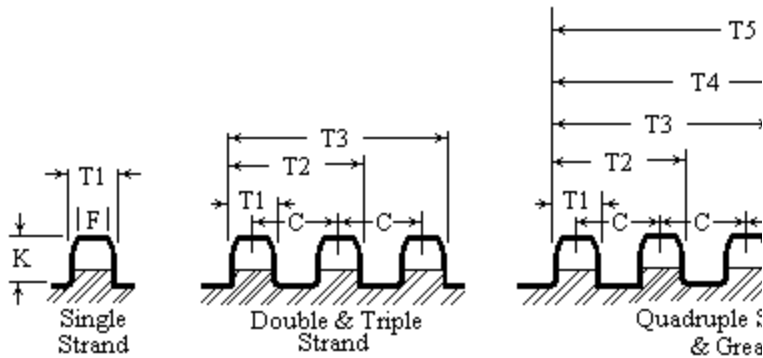

CHAIN NO.	PITCH	ROLLER DIA.	T1 SINGLE	T1 DBL & TRPL	T1 QUAD	TOLERANCE MULTIPLE ONLY (*) C		T2 DOUBLE	T3 TRIPLE	T2 T3 T4 T5 QUADRUPLE & QUINTUPLE			K	F	
25	1/4	.130	.110			-.008								1/16	
35	3/8	.200	.168	.162	.159	-.008	.397	.559	.956	.556	.953	1.350	1.745	.300	1/8
41	1/2	.306	.221			-.009									3/32
40	1/2	.312	.284	.275	.268	-.009	.564	.839	1.403	.832	1.396	1.960	2.520	.400	5/32
50	5/8	.400	.343	.331	.324	-.010	.710	1.041	1.751	1.034	1.744	2.454	3.164	.500	3/16
60	3/4	.468	.459	.444	.434	-.011	.893	1.331	2.230	1.327	2.220	3.113	4.006	.600	1/4
80	1	.625	.575	.556	.544	-.012	1.147	1.703	2.850	1.691	2.838	3.985	5.132	.800	5/16
100	1-1/4	.750	.692	.670	.654	-.014	1.401	2.071	3.472	2.055	3.472	4.857	6.258	1.000	3/8
120	1-1/2	.875	.924	.894	.874	-.016	1.781	2.675	4.472	2.655	4.436	6.215	7.998	1.190	9/16
140	1-3/4	1.000	.924	.894	.848	-.016	1.912	2.806	4.742	2.772	4.696	6.620	8.590	1.375	1/2
160	2	1.125	1.156	1.119	1.063	-.019	2.290	3.424	5.729	3.368	5.673	7.978	10.254	1.600	21/32
180	2-1/4	1.406	1.301	1.259	1.203	-.020	2.592	3.851	6.443	3.795	6.387	8.979	11.570	1.815	11/16
200	2-1/2	1.562	1.389	1.344	1.275	-.021	2.817	4.161	6.978	4.095	6.912	9.729	12.549	1.950	3/4
240	3	1.875	1.138	1.682	1.601	-.025	3.457	5.139	8.596	5.058	8.515	11.972	15.429	2.415	1

Bevel each side is half of pitch; i.e. 3/4"pitch has 3/8" bevel

(*) Tolerance is always on minus side except Type A plate (see page 7-8)

RYLE Manufacturing Company 1-800-433-0960

Maximum Hub Diameters

AMERICAN STANDARD CHAIN NUMBERS AND PITCH IN INCHES												
NO. Teeth	35 3/8"	40 1/2"	50 5/8"	60 3/4"	80 1"	100 1-1/4"	120 1-1/2"	140 1-3/4"	160 " 2"	180 2-1/4"	200 2-1/2"	240 3"
7	0.484	0.627	0.806	0.968	1.253	1.615	1.936	2.262	2.587		3.250	
8	0.602	0.794	1.003	1.204	1.577	2.008	2.408	2.812	3.215	3.140	4.030	
9	0.720	0.961	1.200	1.440	1.901	2.401	2.880	3.362	3.843	3.890	4.810	
10	0.838	1.118	1.397	1.676	2.225	2.794	3.352	3.912	4.471	4.640	5.590	6.204
11	0.956	1.275	1.594	1.912	2.549	3.187	3.824	4.462	5.099	5.375	6.372	7.188
12	1.074	1.432	1.790	2.148	2.863	3.580	4.296	5.012	5.727	6.110	7.160	8.166
13	1.192	1.589	1.987	2.384	3.178	3.973	4.768	5.563	6.357	6.840	7.947	9.141
14	1.310	1.747	2.184	2.621	3.394	4.367	5.241	6.114	6.188	7.580	8.735	10.110
15	1.429	1.905	2.381	2.857	3.809	4.767	5.715	6.667	7.620	8.300	9.525	11.080
16	1.547	2.063	2.579	3.094	4.125	5.157	6.189	7.220	8.252	9.030	10.312	12.050
17	1.666	2.221	2.776	3.382	4.442	5.553	6.666	7.774	8.885	9.750	11.105	13.020
18	1.784	2.379	2.974	3.569	4.758	5.948	7.138	8.328	9.518	10.470	11.891	13.980
19	1.903	2.538	3.172	3.807	5.075	6.345	7.613	8.882	10.151	11.200	12.690	14.950
20	2.022	2.696	3.370	4.044	5.392	6.741	8.089	9.437	10.785	11.915	13.482	15.880
21	2.141	2.855	3.569	4.282	5.709	7.137	8.564	9.992	11.419	12.635	14.275	16.830
22	2.260	3.013	3.767	4.520	6.026	7.533	9.040	10.547	12.053	13.360	15.067	17.783
23	2.379	3.172	3.965	4.758	6.343	7.930	9.516	11.102	12.688	14.080	15.860	18.735
24	2.498	3.331	4.163	4.996	6.661	8.327	9.992	11.657	13.323	14.795	16.651	19.688
25	2.617	3.489	4.362	5.234	6.978	8.723	10.468	12.213	13.958	15.515	17.447	20.640



AMERICAN STANDARD EXTENDED PITCH CHAIN NUMBERS AND PITCH

NO. TEETH	2040 1"	2050 1-1/4"	2060 1-1/2"	2080 2"	2100 2-1/2"	2120 3"	2160 4"
12	1.20	1.51	1.82	2.43	3.05	3.67	4.90
13	1.38	1.73	2.08	2.78	3.48	4.19	5.59
14	1.55	1.94	2.34	3.12	3.91	4.70	6.28
15	1.72	2.15	2.59	3.46	4.34	5.21	6.95
16	1.88	2.36	2.84	3.80	4.76	5.71	7.63
17	2.05	2.57	3.09	4.13	5.17	6.21	8.29
18	2.22	2.80	3.34	4.47	5.59	6.71	8.96
19	2.38	2.99	3.59	4.80	6.00	7.24	9.62
20	2.55	3.19	3.84	5.13	6.41	7.71	10.28
21	2.71	3.40	4.08	5.45	6.83	8.20	10.94
22	2.88	3.60	4.33	5.78	7.23	8.69	11.59
23	3.04	3.81	4.57	6.11	7.64	9.18	12.25
24	3.20	4.04	4.82	6.43	8.05	9.67	12.90
25	3.36	4.21	5.06	6.76	8.46	10.15	13.55



RYLE Manufacturing Company 1-800-433-0960

Tolerances

<u>BORE DIAMETER TOLERANCE OUT</u>	
(always on plus side minus -.000")	
UP TO 2" BORE	+ .002"
FROM 2" TO 3"	+ .003"
FROM 3" TO 4"	+ .004"
FROM 4" TO 5"	+ .005"
Closer than standard tolerances are available at additional cost subject to tolerance and finish desired.	

<u>FACE RUN</u>	
(on type A plate sprockets)	
OUTSIDE DIAMETER	INDICATOR READING
UP TO 12"	0.030"
12" TO 18"	0.050"
18" TO 24"	0.080"
24" & over	0.125"

TYPE A PLATE

NOT MACHINED

<u>ECCENTRICITY</u>	
(as measured from bore to root)	
BOTTOM DIAMETER	INDICATOR READING
Up to 4"	.006"
4" to 5"	.008"
5" to 7"	.010"
7" to 9"	.012"
9" to 11"	.014"
11" to 13"	.016"
13" to 15"	.018"
15" to 20"	.020"
20" to 25"	.024"
25" to 35"	.026"
35" to 45"	.028"
45" to 60"	.032"
60" to 75"	.040"
75" to 100"	.048"

<u>PLATE THICKNESS</u>			
(on type A plate sprockets)			
CHAIN NO.	PITCH inches	PLATE THICKNESS PLUS MINUS	TOLERANCE
35	3/8	.168"	+ .006" -.027"
1/2		.284"	+ .006" -.035"
1/2		.227"	+ .006" -.035"
5/8		.343"	+ .007" -.036"
60	3/4	.459"	+ .009" -.036"
80	1	.575"	+ .015" -.040"
100	1-1/4	.692"	+ .020" -.046"
120	1-1/2	.924"	+ .024" -.057"
140	1-3/4	.924"	+ .024" -.057"
160	2	1.156"	+ .035" -.062"
180	2-1/4	1.301"	+ .045" -.068"
200	2-1/2	1.389"	+ .050" -.070"
240	3	1.738"	+ .062" -.080"



Tolerances

<u>STANDARD KEYWAYS & STANDARD SETSCREWS</u>				
Shaft Diameter		Keyway width x depth	Setscrew Nat'l Course	
1/2"	to	9/16"	1/8" x 1/16"	1/4" NC
5/8"	to	7/8	3/16" x 3/32"	1/4" NC
15/16"	to	1-1/4"	1/4" x 1/8"	1/4" NC
1-5/16"	to	1-3/8"	5/16" x 5/32"	5/16" NC
1-7/16"	to	1-3/4"	3/8" x 3/16"	3/8" NC
1-13/16"	to	2-1/4"	1/2" x 1/4"	1/2" NC
2-5/16"	to	2-3/4"	5/8" x 5/16"	5/8" NC
2-13/16"	to	3-1/4"	3/4" x 3/8"	3/4" NC
3-5/16"	to	3-3/4"	7/8" x 7/16"	7/8" NC
3-13/16"	to	4-1/2"	1" x 1/2"	1" NC
4-9/16"	to	5-1/2"	1-1/4" x 5/8"	1" NC
5-9/16"	to	6-1/2"	1-1/2" x 3/4"	1" NC
6-9/16"	to	7-1/2"	1-3/4" x 5/8"(*)	1" NC
7-9/16"	to	8-15/16"	2" x 3/4"(*)	1" NC
9"	to	10-15/16"	2-1/2" x 7/8"(*)	1" NC

(*) Standard Flat Keyway will be furnished unless otherwise specified at time of order

<u>ACTUAL PLATE THICKNESS</u>	
GRADE C1035 DOMESTIC (type A plate - mill scale)	
chain	plate thickness
40	1/4"
50	5/16"
60	7/16"
80	9/16"
100	11/16"
120	7/8"
140	7/8"
160	1-1/8"
180	1-3/8"
200	1-3/8"
240	1-3/4"

Type A plate (face not machined)
Grade C1040



RYLE Manufacturing Company 1-800-433-0960

QD[®] Weld-on Adapters

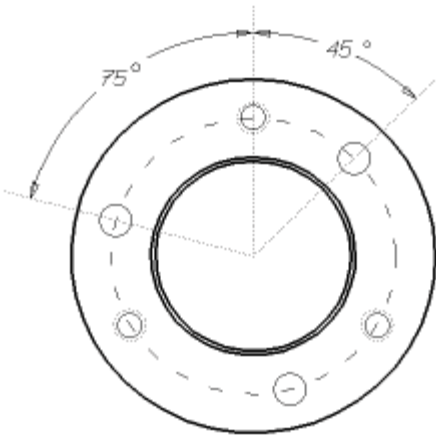

Type 1 Drill Pattern for JA thru J

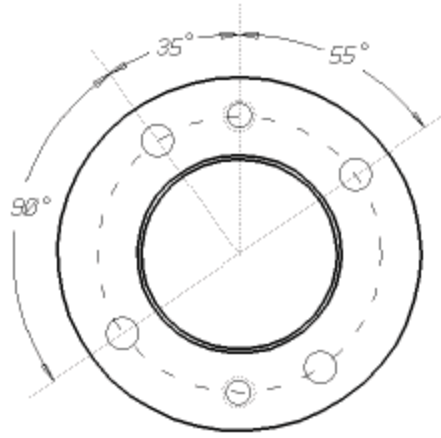

Type 2 Drill Pattern for M thru W

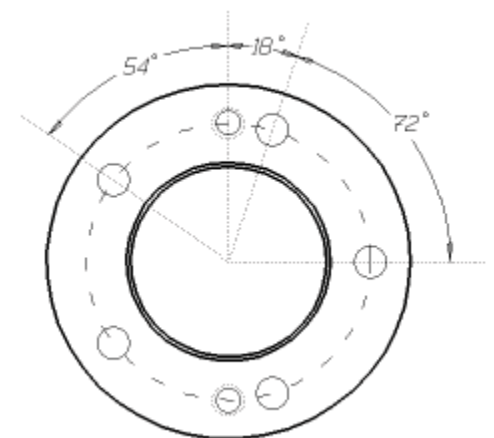

Type 3 Drill Pattern for S

RYLE P/N	LIST PRICE	HUB O.D.	L	DIMENSIONS		DRILL TYPE	CAPSCREW SIZE	LBS
				A	B.C.			
AD-SH	54.00	3	13/16	1.871	2-1/4	1	1/4 x 1-3/8	.9
AD-SDS	72.00	3-1/2	3/4	2.188	2-11/16	1	1/4 x 1-3/8	1.5
AD-SK	96.00	4-3/8	1-1/4	2.813	3-5/16	1	5/16 x 2	2.5
AD-SF	150.00	5	1-1/4	3.125	3-7/8	1	3/8 x 2-1/4	3.3
AD-E	216.00	6-1/4	1-5/8	3.832	5	1	1/2 x 2-3/4	7.9
AD-F	336.00	7	2-1/2	4.437	5-5/8	1	9/16 x 3-3/4	12.5
AD-J	432.00	7-3/4	3-3/16	5.140	6-1/4	1	5/8 x 4-1/2	21.0
AD-M	1140.00	9-3/4	5-3/16	6.494	7-7/8	2	3/4 x 7	54.0
AD-N	1680.00	11	6-1/4	6.990	8-1/2	2	7/8 x 8-1/2	96.0
AD-P	2550.00	13	7-1/4	8.240	10	2	1 x 9-1/2	150.0
AD-W	4050.00	15-1/2	9	10.440	12-3/4	2	1-1/8 x 11	300.0
AD-S	7240.00	17-3/4	12	12.125	15	3	1-1/4 x 15	450.0

tolerance for O.D. of SH - SF is +.000/-.003"
 tolerance for O.D. of E - W is +.000/-.005"

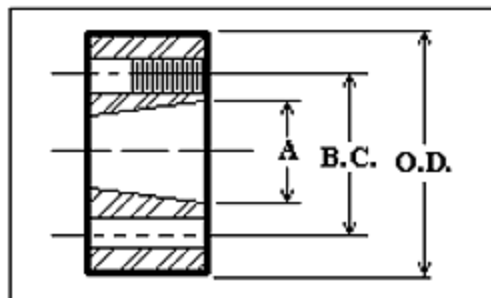

QD Used throughout this catalog is a registered trademark of and used under licence from Emerson Electric.



RYLE Manufacturing Company 1-800-433-0960

QD[®] BUSHINGS

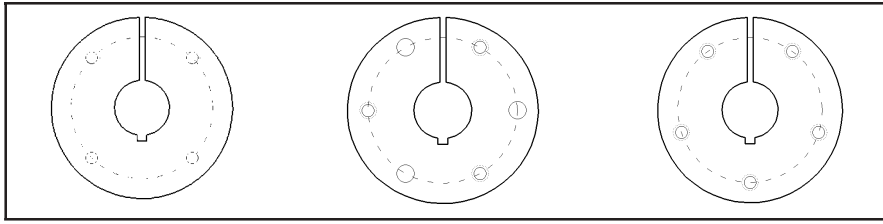

BUSHING No.	LIST PRICE	DIMENSIONS							CAP SCREWS REQUIRED & SIZE	MIN BORE	STOCK BORE RANGE		SETScrew SIZE	LBS
		A	B	D	E	G	L	B.C.			STD KEY	SHALLOW KEY		
JA	21.80	5/16	1.375	2	11/16	1	1.665		(3) 10 x 1"	3/8	1	1-1/4	10-24	.9
SH	29.80	7/16	1.871	2-11/16	7/8	1/8	1-5/16	2.250	(3) 1/4" x 1-3/8"	1/2	1-3/8	1-11/16	1/4-20	1.2
SDS	34.60	7/16	2.187	3-3/16	7/8	1/8	1-5/16	2.687	(3) 1/4" x 1-3/8"	1/2	1-11/16	2	1/4-20	1.7
SK	53.60	9/16	2.812	3-7/8	1-3/8	1/8	1-15/16	3.312	(3) 5/16" x 2"	1/2	2-1/8	2-1/2	5/16-18	2.4
SF	66.00	5/8	3.125	4-5/8	1-1/2	1/8	2-1/16	3.875	(3) 3/8" x 2"	1/2	2-5/16	2-13/16	5/16-18	4.0
E	138.40	7/8	3.834	6	1-7/8	1/8	2-3/4	5	(3) 1/2" x 2-3/4"	7/8	2-7/8	3-1/2	3/8-16	10
F	248.00	1	4.437	6-5/8	2-13/16	3/16	3-3/4	5.625	(3) 9/16" x 3-5/8"	1	3-5/16	3-15/16	1/2-13	11
J	308.00	1-1/8	5.145	7-1/4	3-1/2	3/16	4-5/8	6.250	(3) 5/8" x 4-1/2"	1-7/16	3-3/4	4-1/2	5/8-11	20
M	616.00	1-1/4	6.496	9	5-1/2	3/16	6-3/4	7.875	(4) 3/4" x 6-3/4"	1-15/16	4-3/4	5-1/2	3/4-10	46
N	1080.00	1-1/2	6.992	10	6-5/8	1/4	8-1/8	8.500	(4) 7/8" x 8-1/2"	2-7/16	5-1/8	6	3/4-10	65
P	1620.00	1-3/4	8.242	11-3/4	7-5/8	1/4	9-3/8	10	(4) 1" x 9-1/2"	2-15/16	5-15/16	7	7/8-9	120
W	2880.00	2	10.429	15	9-3/8	1/4	11-3/8	12.750	(4) 1-1/8" x 11-1/2"	4	7-1/2	8-1/2	1-8	250
S	6800.00	2-3/4	12.125	17-3/4	12-1/2	3/8	15-1/4	15	(5) 1-1/4" x 15-1/2"	6	8-1/4	10	1-1/4	400

F dimension is length of mating hub

BUSHING	BORES	KEYWAY
JA	3/8 - 9/16 5/8 - 1 1-1/16 - 1-3/16 1-1/4	NO KEY STANDARD 1/4 x 1/16 NO KEY
SH	1/2 - 1-1/4 1-5/16 - 1-3/8 1-7/16 - 1-1/2 1-9/16 - 1-5/8 1-11/16	STANDARD 3/8 x 1/8 3/8 x 1/16 3/8 x 1/32 NO KEY
SDS	1/2 - 1-9/16 1-5/8 - 1-3/4 1-13/16 - 1-15/16 2	STANDARD 3/8 x 1/8 1/2 x 1/16 1/2 x 1/32
SK	1/2 - 2 2-1/16 - 2-1/4 2-5/16 - 2-1/2 2-9/16 - 2-5/8	STANDARD 1/2 x 1/8 5/8 x 1/16 5/8 x 1/32
SF	1/2 - 2-1/4 2-9/16 - 2-3/4 2-13/16 - 2-7/8 2-15/16	STANDARD 5/8 x 1/16 3/4 x 1/16 3/4 x 1/32

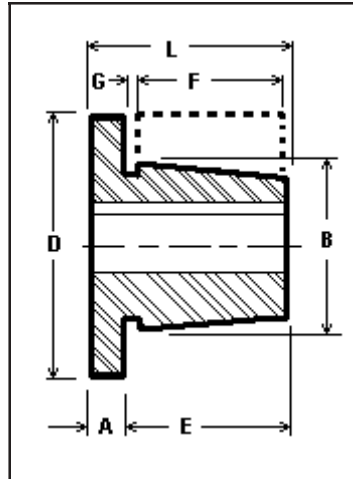

BUSHING	BORES	KEYWAY
E	7/8 - 2-3/4 2-13/16 - 3-1/4 3-5/16 - 3-1/2 1 - 3-1/4	STANDARD 3/4 x 1/8 7/8 x 1/16 STANDARD
F	3-5/16 - 3-3/4 3-13/16 - 3-7/8 3-15/16 4	7/8 x 3/16 1 x 1/8 1 x 1/16 NO KEY
J	1-7/16 - 3-5/8 3-11/16 - 3-3/4 3-13/16 - 4-7/16	STANDARD 7/8 x 3/16 1 x 1/8
M	2 - 4-11/16 4-3/4 - 5-1/4 5-5/16 - 5-1/2	STANDARD 1-1/4 x 1/4 1-1/4 x 1/8
N	2-1/2 - 5 5-1/16 - 5-1/2 5-9/16 - 5-7/8	STANDARD 1-1/4 x 1/4 1-1/2 x 1/4
P	2-15/16 - 5-11/16 5-3/4 - 6-1/2 6-9/16 - 7	STANDARD 1-1/2 x 1/4 1-3/4 x 1/4
W	2-5/16 - 2-1/2 4-7/16 - 7 7-1/16 - 7-1/2 7-9/16 - 8-1/2	5/8 x 3/16 STANDARD 1-3/4 x 1-3/8 2 x 5/16



RYLE Manufacturing Company 1-800-433-0960

No. 25 1/4" Pitch

Type B

Type A

RYLE P/N	LIST PRICE	NO. TEETH	O.D. TEETH	STOCK BORE	MAX BORE	HUB DIA	LTB	LBS	RYLE P/N	LIST PRICE	LBS.
25B9	16.00	9	.84	1/4	1/4	7/16	1/2	.03			
25B10	16.40	10	.92			1/2		.04			
25B11	16.80	11	1.00		5/16	9/16		.05			
25B12	17.40	12	1.08		3/8	5/8		.06			
25B13	18.20	13	1.17		7/16	23/32		.07			
25B14	18.60	14	1.25		9/16	13/16		.08			
25B15	18.60	15	1.33			7/8		.10			
25B16	19.20	16	1.41		5/8	31/32		.12			
25B17	19.60	17	1.49		21/32	1-1/32		.14			
25B18	20.40	18	1.57		3/4	1-1/8		.16	25A18	21.00	.04
25B19	20.40	19	1.65		13/16	1-7/32		.19	25A19	21.20	.04
25B20	21.00	20	1.73		7/8	1-9/32	5/8	.25	25A20	21.20	.04
25B21	21.80	21	1.81		7/8	1-3/8		.25	25A21	21.40	.05
25B22	22.20	22	1.89		15/16	1-7/16		.31	25A22	21.60	.06
25B23	23.20	23	1.97		1	1-1/2		.32	25A23	22.00	.07
25B24	24.40	24	2.05	3/8				.33	25A24	22.20	.07
25B25	24.80	25	2.13					.34	25A25	22.60	.08
25B26	25.80	26	2.21					.35	25A26	23.20	.09
25B28	28.00	28	2.37					.37	25A28	24.00	.10
25B30	29.80	30	2.53					.39	25A30	24.00	.12
25B32	32.40	32	2.69					.41	25A32	28.60	.14
25B35	34.00	35	2.93					.46	25A35	29.40	.16
25B36	36.60	36	3.01				3/4	.49	25A36	29.60	.18
25B40	41.80	40	3.33	1/2	1-3/8	2		.52	25A40	30.40	.20
25B45	45.80	45	3.73					.55	25A45	31.20	.25
25B48	49.40	48	3.96					.57	25A48	31.80	.32
25B54	54.80	54	4.44					.98	25A54	33.00	.38
25B60	60.60	60	4.92					1.10	25A60	34.00	.54
25B70	70.40	70	5.72					1.20			
25B72	72.60	72	5.88					1.25	25A72	36.20	.74
						REBORE	\$49.00				
						KEYWAY	\$13.40				
						SETSCREW (EACH)	\$13.40				
						HARDEN PER TOOTH	\$ 0.76				

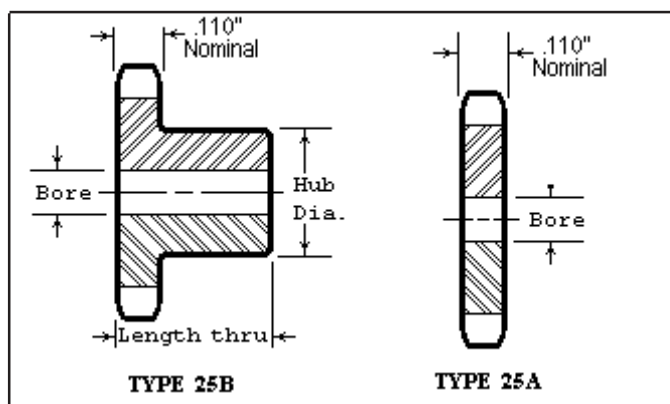



RYLE Manufacturing Company 1-800-433-0960

No. 25 1/4" Pitch Stainless Steel

RYLE P/N	LIST PRICE	NO. TEETH	O.D. TEETH	STOCK BORE	MAX BORE	HUB DIA	LTB	LBS
25B9SS	102.40	9	.84	1/4	1/4	7/16	1/2	.03
25B10SS	104.60	10	.92			1/2		.04
25B11SS	106.80	11	1.00		5/16	9/16		.05
25B12SS	110.80	12	1.08		3/8	5/8		.06
25B13SS	115.20	13	1.17		7/16	23/32		.07
25B14SS	117.40	14	1.25		9/16	13/16		.08
25B15SS	119.20	15	1.33			7/8		.10
25B16SS	122.00	16	1.41		5/8	31/32		.12
25B17SS	123.80	17	1.49		21/32	1-1/32		.14
25B18SS	127.60	18	1.57		3/4	1-1/8		.16
25B19SS	130.40	19	1.65		13/16	1-7/32		.19
25B20SS	132.20	20	1.73		7/8	1-9/32	5/8	.25
25B21SS	139.40	21	1.81		7/8	1-3/8		.25
25B22SS	144.60	22	1.89		15/16	1-7/16		.31
25B23SS	150.80	23	1.97		1	1-1/2		.32
25B24SS	153.40	24	2.05	3/8				.33
25B25SS	158.40	25	2.13					.34
25B26SS	171.40	26	2.21					.35
25B28SS	186.80	28	2.37					.37
25B30SS	203.80	30	2.53					.39
25B36SS	286.20	36	3.01				3/4	.49
25B40SS	342.60	40	3.33	1/2	1-3/8	2		.52
25B45SS	384.80	45	3.73					.55
25B60SS	503.80	60	4.92					1.10
REBORE		\$49.00						
KEYWAY		\$13.40						
SETSCREW (EACH)		\$13.40						

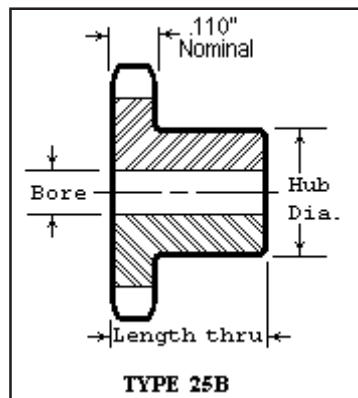



RYLE Manufacturing Company 1-800-433-0960

No. 35 3/8" Pitch

Type B

Type A

RYLE P/N	LIST PRICE	NO TEETH	O.D. TEETH	STOCK BORE	MAX BORE	HUB DIA	LTB	LBS	RYLE P/N	LIST PRICE	LBS
35B8	14.20	8	1.13	3/8	3/8	3/4 *	3/4	.08			
35B9	14.60	9	1.26			27/32*	3/4	.10			
35B10	15.60	10	1.38		9/16	21/32*	3/4	.15			
35B11	16.00	11	1.50		5/8	1-1/16*	3/4	.20			
35B12	16.80	12	1.63	1/2	3/4	1-7/32*	3/4	.22			
35B13	17.40	13	1.75			1-1/4 *	3/4	.25			
35B14	18.20	14	1.87		7/8		3/4	.26			
35B15	18.60	15	1.99		13/16	1-3/8	3/4	.30	35A15	22.20	.16
35B16	19.60	16	2.11		15/16	1-15/32	3/4	.40	35A16	22.20	.18
35B17	19.60	17	2.23		1-1/16	1-5/8	3/4	.43	35A17	23.20	.21
35B18	20.40	18	2.35		1-3/16	1-3/4	3/4	.50	35A18	23.20	.24
35B19	21.00	19	2.47		1-1/4	1-7/8	3/4	.56	35A19	23.60	.26
35B20	23.20	20	2.59		1-5/16	1-15/16	3/4	.68	35A20	24.40	.29
35B21	24.80	21	2.71		1-3/8	2-1/8	3/4	.80	35A21	24.40	.31
35B22	27.60	22	2.83				3/4	.82	35A22	24.80	.34
35B23	29.80	23	2.95				3/4	.87	35A23	24.80	.38
35B24	31.60	24	3.07				7/8	.89	35A24	25.80	.41
35B25	33.80	25	3.19				7/8	.97	35A25	25.80	.44
35B26	35.20	26	3.31		1-1/2	2-1/4	1	.93	35A26	26.20	.46
35B27	36.80	27	3.43				1	.97	35A27	27.20	.51
35B28	37.80	28	3.55				1	1.00	35A28	27.20	.53
		29	3.67						35A29	27.40	.57
35B30	38.20	30	3.79				1	1.06	35A30	27.60	.59
35B32	39.60	32	4.03				1	1.12	35A32	28.40	.67
35B35	43.60	35	4.39	5/8			1	1.56	35A35	29.00	.75
35B36	44.40	36	4.51				1	1.68	35A36	29.80	.85
35B40	47.60	40	4.99				1	1.70	35A40	31.20	1.04
35B42	49.80	42	5.23				1	2.00	35A42	33.00	1.05
35B45	52.40	45	5.59				1	2.18	35A45	33.80	1.15
35B48	55.20	48	5.95				1	2.40	35A48	35.20	1.26
35B54	64.40	54	6.86				1	2.65	35A54	38.20	1.76
35B60	75.20	60	7.38	3/4			1	3.00	35A60	41.80	2.10
35B70	87.20	70	8.58				1	3.70	35A70	47.60	2.90
35B72	89.00	72	8.81				1	3.90	35A72	47.60	2.90
35B80	99.20	80	9.77				1	4.50	35A80	52.40	3.50
35B84	103.60	84	10.25				1	4.85	35A84	55.60	3.90
35B96	120.60	96	11.68				1	6.00	35A96	71.60	5.00
35B112	140.60	112	13.59				1	7.75	35A112	89.00	6.75

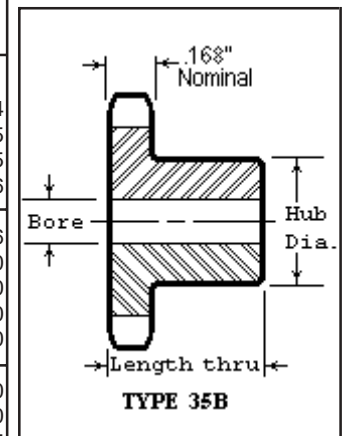
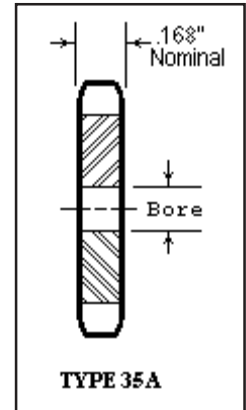

* Indicates Hub Diameter grooved for chain clearance.

Maximum bores will accommodate standard keyway and setscrew over key. Slightly larger bores may be possible with shallow keyway and/or setscrew at 90 degrees. Multiple keyways must be priced at factory.

Split Type A plate	\$ 2.76 per inch of sprocket diameter	Type A plate(4) holes = \$28.00
Rebore	\$49.00	(6) holes = \$42.00
Keyway	\$13.40	(8) holes = \$56.00
Setscrew (each)	\$13.40	
Harden per tooth	\$0.76	



RYLE Manufacturing Company 1-800-433-0960

No. 35 3/8" Pitch Bored to Size

RYLE P/N	LIST PRICE	NO TEETH	LBS	RYLE P/N	LIST PRICE	AVAILABLE BORE SIZES WITH KEYWAY AND 2)SS					
35BS9	19.20	9	.10	35BS9H	21.60	3/8 +					
35BS10	19.60	10	.11	35BS10H	23.20	3/8 + 1/2 5/8 *					
35BS11	20.40	11	.15	35BS11H	24.40	3/8 + 1/2 5/8 * 3/4 *					
35BS12	21.00	12	.21	35BS12H	26.00	1/2 5/8 3/4					
35BS13	21.80	13	.25	35BS13H	27.20	1/2 5/8 3/4					
35BS14	21.80	14	.30	35BS14H	28.80	1/2 5/8 3/4					
35BS15	22.20	15	.34	35BS15H	30.00	1/2 5/8 3/4 1 *					
35BS16	23.60	16	.37	35BS16H	31.80	1/2 5/8 3/4 1 *					
35BS17	24.40	17	.46	35BS17H	32.60	1/2 5/8 3/4 1					
35BS18	25.80	18	.53	35BS18H	34.20	1/2 5/8 3/4 1					
35BS19	29.00	19	.60	35BS19H	35.40	1/2 5/8 3/4					
35BS20	32.40	20	.68	35BS20H	38.40	1/2 5/8 3/4					
35BS21	36.00	21	.74	35BS21H	40.80	1/2 5/8 3/4 1					
35BS22	39.20	22	.78	35BS22H	44.40	1/2 5/8 3/4 1					
35BS23	41.80	23	.81	35BS23H	47.20	1/2 5/8 3/4 1					
35BS24	44.40	24	.84	35BS24H	49.80	1/2 5/8 3/4 1					
35BS25	47.60	25	.84	35BS25H	52.80	1/2 5/8 3/4 1					
35BS26	50.40	26	.88	35BS26H	55.00	5/8 3/4 7/8 1 1-1/8 1-3/16 1-1/4					
35BS27	52.20	27	.97			5/8 3/4 7/8 1 1-1/8 1-3/16 1-1/4					
35BS28	54.80	28	1.00	35BS28H	59.00	5/8 3/4 7/8 1 1-1/8 1-3/16 1-1/4					
35BS30	59.20	30	1.06	35BS30H	61.00	5/8 3/4 7/8 1 1-1/8 1-3/16 1-1/4					
35BS32	64.20	32	1.12			5/8 3/4 7/8 1 1-1/8 1-3/16 1-1/4					
35BS35	71.20	35	1.70			5/8 3/4 7/8 1 1-1/8 1-3/16 1-1/4					
35BS40	74.40	40	1.80			5/8 3/4 7/8 1 1-1/8 1-3/16 1-1/4					
35BS45	79.20	45	2.00			5/8 3/4 7/8 1 1-1/8 1-3/16 1-1/4					
35BS60	105.40	60	2.80			3/4 7/8 1 1-1/8 1-3/16 1-1/4					

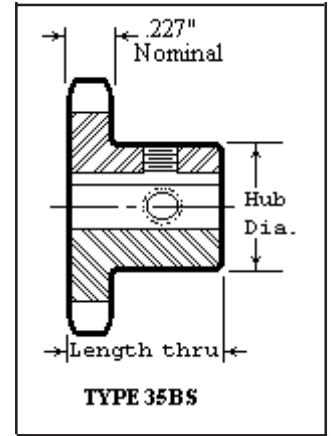

+ Indicates No Keyway
 * Setscrew at 90 degrees only
 Hub diameters may vary to suit bore sizes

Type B stock Bore with Hard Teeth

RYLE P/N	LIST PRICE
35B9H	21.60
35B10H	23.20
35B11H	24.40
35B12H	26.00
35B13H	27.20
35B14H	28.80
35B15H	30.00
35B16H	31.80
35B17H	32.60
35B18H	34.20
35B19H	35.40
35B20H	38.40
35B21H	40.80
35B22H	44.40
35B23H	47.20
35B24H	49.80
35B25H	52.80
35B26H	55.00
35B28H	59.00
35B30H	61.00

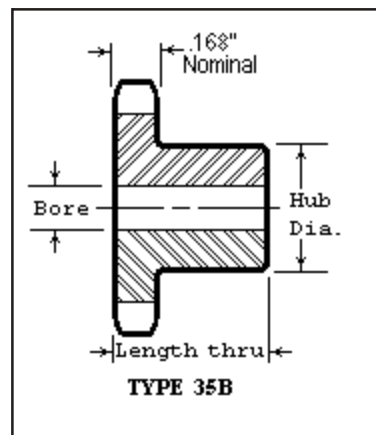



RYLE Manufacturing Company 1-800-433-0960

No. 35 3/8" Pitch

RYLE P/N	LIST PRICE	O.D.	MAX BORE	L1	L2	C	Y	G	X	T	LBS
35QD19JA	37.40	2.47	1-1/4	1-1/8	1-1/8	2-1/16	53/64	29/64	5/8	.168	.4
35QD20JA	39.20	2.59									.5
35QD21JA	41.00	2.71									.5
35QD22JA	43.60	2.83									.5
35QD23JA	52.40	2.95									.5
35QD24JA	53.40	3.07									.5
35QD25JA	56.00	3.19									.6
35QD26JA	58.20	3.31									.6
35QD27JA	59.60	3.43									.6
35QD28JA	61.00	3.55									.7
35QD30JA	61.80	3.79									.7
35QD32JA	65.40	4.03									.8
35QD35JA	67.60	4.39	1-1/4	1-1/8	1-1/8	2-1/16	53/64	29/64	5/8	.168	.8
35QD36SH	67.80	4.51	1-5/8	1-7/16	1-7/16	2-11/16	1-5/64	41/64	13/16	.168	.8
35QD40SH	68.00	4.99									1.0
35QD42SH	69.40	5.23									1.1
35QD45SH	71.60	5.59									1.2
35QD48SH	76.60	5.95									1.3
35QD54SH	86.40	6.66									1.6
35QD60SH	112.60	7.38									2.0
35QD70SH	123.80	8.58									2.5
35QD72SH	128.20	8.81									2.9
35QD80SH	137.60	9.77									3.8
35QD84SH	141.00	10.25									4.9
35QD96SH	163.40	11.68									5.3
35QD112SH	189.20	13.59	1-5/8	1-7/16	1-7/16	2-11/16	1-5/64	41/64	13/16	.168	8.6

Harden per tooth\$ 0.76

QD Bushing dimensions and prices page 10

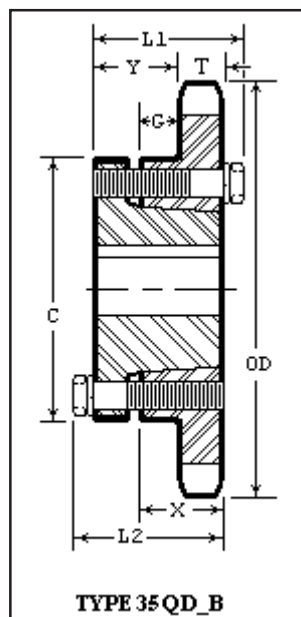



RYLE Manufacturing Company 1-800-433-0960

No. 35 3/8" Pitch Stainless Steel

Type B

Type A

RYLE P/N	LIST PRICE	NO TEETH	O.D. TEETH	STOCK BORE	MAX BORE	HUB DIA	LTB	LBS	RYLE P/N	LIST PRICE	LBS
35B9SS	93.80	9	1.26	3/8	3/8	3/4 *	3/4	.10			
35B10SS	98.00	10	1.38		9/16	27/32*	3/4	.15			
35B11SS	102.40	11	1.50		5/8	1-1/16*	3/4	.20			
35B12SS	106.80	12	1.83	1/2	3/4	1-7/32*	3/4	.22			
35B13SS	110.80	13	1.75		3/4	1-1/4 *	3/4	.25			
35B14SS	115.20	14	1.87		7/8	1-1/4	3/4	.26			
35B15SS	119.20	15	1.99		13/16	1-3/8	3/4	.30			
35B16SS	123.80	16	2.11		15/16	1-15/32	3/4	.40			
35B17SS	125.60	17	2.23		1-1/16	1-5/8	3/4	.43			
35B18SS	127.60	18	2.35		1-3/16	1-3/4	3/4	.50			
35B19SS	134.00	19	2.47		1-1/4	1-7/8	3/4	.56			
35B20SS	146.00	20	2.59		1-5/16	1-15/16	3/4	.68			
35B21SS	159.00	21	2.71		1-3/8	2-1/8	3/4	.80			
35B22SS	171.40	22	2.83				3/4	.82			
35B23SS	189.20	23	2.95				3/4	.87			
35B24SS	206.80	24	3.07				7/8	.89			
35B25SS	225.20	25	3.19				7/8	.97			
35B26SS	243.60	26	3.31		1-1/2	2-1/4	1	.93			
35B28SS	287.00	28	3.55				1	1.00			
35B30SS	314.60	30	3.79				1	1.06	30A30SS	248.00	.59
35B35SS	363.60	32	4.03				1	1.56	35A32SS	269.80	.67
35B40SS	398.60	35	4.39	5/8			1	1.70	35A35SS	291.60	.75
35B45SS	447.60	40	4.99				1	1.70	35A40SS	319.20	1.04
35B45SS	447.60	45	5.59				1	2.18	35A45SS	358.20	1.15
35B60SS	629.20	60	7.38				1	3.00	35A60SS	502.80	2.10

* Indicates Hub Diameter grooved for chain clearance.

Maximum bores will accommodate standard keyway and setscrew over key. Slightly larger bores may be possible with shallow keyway and/or setscrew at 90 degrees. Multiple keyways must be priced at factory. All grade 304 stainless.

Rebore	\$49.00	Drill Type A plate	(4) holes = \$28.00
Keyway	\$13.40		(6) holes = \$42.00
Setscrew (each)	\$13.40		(8) holes = \$56.00

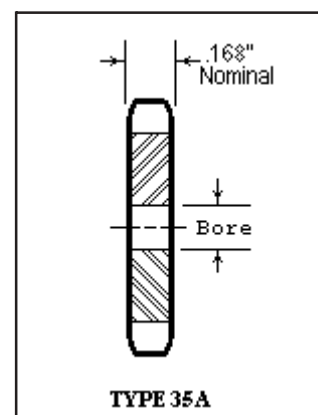
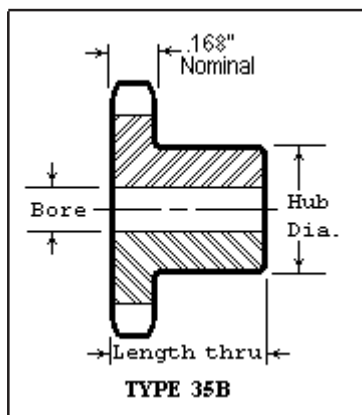

RYLE Manufacturing Company 1-800-433-0960

No.35-2 Double & No.35-3 Triple 3/8" Pitch

RYLE P/N	LIST PRICE	NO. TEETH	O.D. TEETH	STOCK BORE	MAX BORE	HUB DIA	LTB	LBS
D35B13H	44.40	13	1.75	1/2	3/4	1-1/8	1-1/4	.35
D35B14H	45.00	14	1.87		13/16	1-1/4		.42
D35B15H	45.80	15	1.99		7/8	1-11/32		.53
D35B16H	46.20	16	2.11		15/16	1-15/32		.63
D35B17H	49.80	17	2.23		1-1/16	1-19/32		.74
D35B18H	52.40	18	2.35		1-1/8	1-23/32		.86
D35B19H	55.20	19	2.47		1-1/4	1-27/32		1.00
D35B20H	58.80	20	2.59		1-5/16	1-31/32	1-3/8	1.15
D35B21H	61.00	21	2.71		1-3/8	2-1/16		1.30
D35B22H	63.60	22	2.83		1-7/16	2-3/16		1.50
D35B23H	65.80	23	2.95		1-1/2	2-5/16		1.65
D35B24H	68.00	24	3.07		1-5/8	2-7/16		1.75
D35B25H	70.40	25	3.19		1-11/16	2-9/16		1.85
D35B26	72.40	26	3.31		1-3/4	2-11/16		2.26
D35B30	73.80	30	3.79		1-3/4	2-1/2		2.50
D35B36	88.60	36	4.51	3/4	1-3/4	2-1/2		3.10
D35B42	103.20	42	5.23					3.88
D35B48	108.60	48	5.95					5.00
D35B52	123.20	52	6.43					5.40
D35B60	139.40	60	7.38					6.80
D35B68	158.00	68	8.34	1	2-3/8	3-1/2	1-1/2	10.01
D35B72	171.40	72	8.81	1				11.04
D35B76	181.00	76	9.29	1				11.94
D35B84	219.40	84	10.25	1				14.98
D35B96	252.80	96	11.68	1				18.14

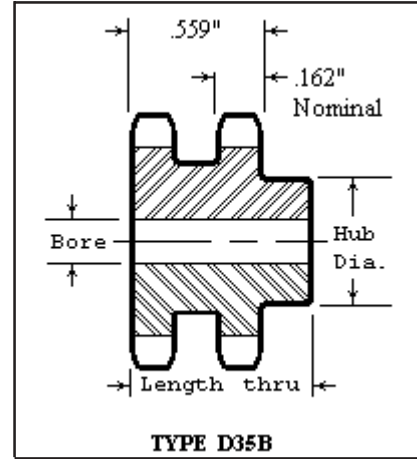

REBORE	\$49.00
KEYWAY	\$13.40
SETSCREW (EACH)	\$13.40
HARDENING (PER TOOTH)	\$.76

Maximum Bore allows for standard keyway and setscrew over key. Slightly larger bores may be possible with shallow keyway and/or setscrew at an angle to key. Multiple keyways must be priced at factory.

RYLE P/N	LIST PRICE	NO. TEETH	O.D. TEETH	STOCK BORE	MAX BORE	HUB DIA	LTB	LBS
E35B13H	66.80	13	1.75	1/2	3/4	1-1/8	1-3/4	.49
E35B14H	67.60	14	1.87		13/16	1-1/4		.61
E35B15H	68.60	15	1.99		7/8	1-11/32		.70
E35B16H	69.80	16	2.11		15/16	1-15/32		.80
E35B17H	71.20	17	2.23		1-1/16	1-19/32		1.00
E35B18H	75.60	18	2.35	1/2	1-1/8	1-23/32	1-3/4	1.20
E35B19H	80.60	19	2.47		1-1/4	1-27/32		1.40
E35B20H	86.40	20	2.59	3/4	1-5/16	1-31/32	1-7/8	1.60
E35B21H	91.60	21	2.71		1-3/8	2-1/16		1.70
E35B22H	95.20	22	2.83		1-7/16	2-3/16		1.82
E35B23H	107.20	23	2.95	3/4	1-1/2	2-5/16	1-7/8	2.30
E35B24H	108.60	24	3.07		1-5/8	2-7/16		2.60
E35B25H	110.40	25	3.19		1-3/4	2-1/2		2.80
E35B26	105.00	26	3.31					3.10
E35B30	117.00	30	3.79					3.70
E35B36	133.00	36	4.51	3/4	1-3/4	2-1/2	1-7/8	4.20
E35B42	146.40	42	5.23					5.80
E35B48	162.40	48	5.95					7.00
E35B52	177.20	52	6.43					9.80
E35B60	199.40	60	7.38					12.80
E35B68	218.00	68	8.34	1	2-3/8	3-1/2	1-7/8	18.40
E35B72	233.60	72	8.81	1				20.30
E35B76	240.40	76	9.29	1				22.40
E35B84	295.40	84	10.25	1				26.80
E35B96	369.80	96	11.68	1				34.30

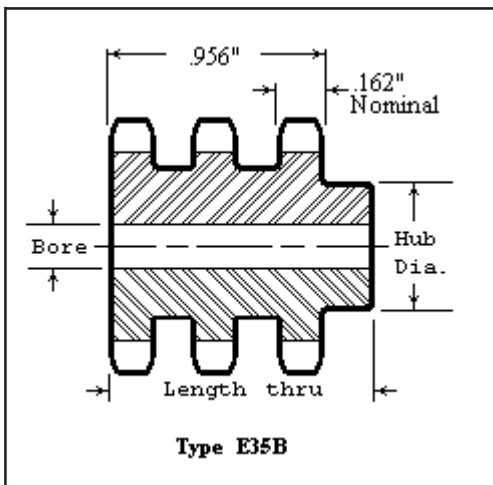

Maximum Bore allows for standard keyway and setscrew(s).



RYLE Manufacturing Company 1-800-433-0960

No. 41 1/2" Pitch

Type B

Type A

RYLE P/N	LIST PRICE	NO. TEETH	O.D. TEETH	STOCK BORE	MAX BORE	HUB DIA	LTB	LBS	RYLE P/N	LIST PRICE	LBS
41B8	16.80	8	1.51	1/2	1/2	31/32 *	7/8	.12			
41B9	17.40	9	1.67		5/8	1-1/8 *		.18			
41B10	18.20	10	1.84		3/4	1-1/4 *		.19			
41B11	18.60	11	2.00		7/8	1-15/32*		.20			
41B12	19.60	12	2.17		1	1-9/16		.35			
41B13	20.40	13	2.33	1/2	1	1-9/16	7/8	.43			
41B14	21.00	14	2.49		1-1/4	1-3/4		.56	41A15	25.80	.32
41B15	21.80	15	2.65		1-5/16	1-29/32		.68	41A16	25.80	.36
41B16	21.80	16	2.81	5/8	1-3/8	2-1/16		.70	41A17	26.20	.40
41B17	24.40	17	2.98		1-1/2	2-15/64		1.00			
41B18	27.20	18	3.14	5/8	1-5/8	2-3/8	7/8	1.10	41A18	26.20	.48
41B19	31.20	19	3.30		1-3/4	2-15/32		1.30	41A19	27.20	.52
41B20	35.20	20	3.46		1-7/8	2-3/4	1	1.56	41A20	27.60	.57
41B21	40.40	21	3.62				1	1.68	41A21	28.40	.66
41B22	43.60	22	3.78				1	1.80	41A22	29.00	.71
41B23	49.00	23	3.94	5/8	1-7/8	2-3/4	1	2.10	41A23	29.80	.76
41B24	51.60	24	4.10				1	2.20	41A24	30.20	.86
41B25	54.20	25	4.26				1	2.35	41A25	31.20	.92
41B26	57.00	26	4.42				1	2.40	41A26	31.60	1.00
41B27	60.60	27	4.58		2-1/4	3-1/4	1	2.43	41A27	32.40	1.03
41B28	61.80	28	4.74	5/8	2-1/4	3-1/4	1	2.50	41A28	33.00	1.09
41B30	63.60	30	5.06				1	2.75	41A30	34.20	1.21
41B32	65.00	32	5.38	3/4			1	2.87	41A32	35.60	1.36
41B35	68.60	35	5.86				1	3.12	41A35	37.80	1.80
41B36	69.80	36	6.02				1	3.62	41A36	38.20	1.98
41B40	72.60	40	6.65	3/4	2-1/4	3-1/4	1	3.70	41A40	39.60	2.30
41B42	75.20	42	6.97		2-1/2	3-3/4	1	3.80	41A42	41.80	2.70
41B45	78.00	45	7.45				1	4.00	41A45	42.20	3.10
41B48	80.60	48	7.93				1	4.60	41A48	44.40	3.50
41B54	85.80	54	8.89				1	5.20	41A54	50.40	4.39
41B60	90.40	60	9.84	3/4	2-1/2	3-3/4	1	6.00	41A60	56.60	5.20
41B70	108.60	70	11.43		2-3/4	4	1-1/4	10.00	41A70	67.20	7.31
41B72	112.60	72	11.75					11.10	41A72	69.80	7.68
41B80	125.80	80	13.03	1				11.50	41A80	81.80	9.31
41B84	131.20	84	13.66	1				12.20	41A84	87.20	10.00
41B96	180.60	96	15.57	1	2-3/4	4	1-1/4	15.00	41A96	103.60	13.30
41B112	247.40	112	18.12	1				18.50	41A112	130.40	17.00

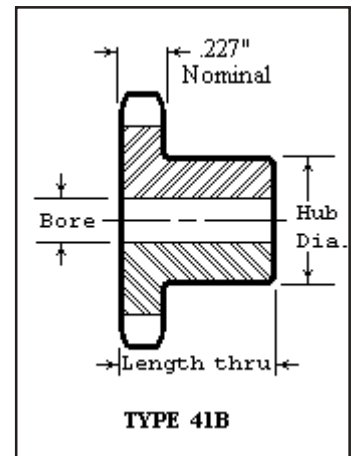
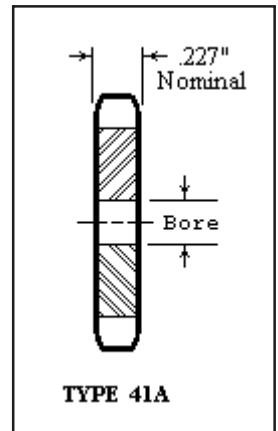

* Hub diameter is grooved for chain clearance.

Maximum bore allows for keyway and setscrew over key. Slightly larger bores may be possible with shallow key and/or setscrew at an angle to key.

Rebore \$49.00
Keyway \$13.40
Setscrew (each) \$13.40
Harden per tooth \$.94

Drill Type A plate (4) holes = \$28.00
(6) holes = \$42.00
(8) holes = \$56.00
Split Type A Plate \$ 2.76 per inch of sprocket dia



RYLE Manufacturing Company 1-800-433-0960

No. 41 1/2" Pitch

RYLE P/N	LIST PRICE	NO. TEETH	O.D. TEETH	LBS	AVAILABLE BORE SIZES WITH KEYWAY AND 2)SS			
41BS9	20.40	9	1.67	.18	1/2	5/8		
41BS10	21.40	10	1.84	.19	1/2	5/8	3/4	
41BS11	22.20	11	2.00	.20	1/2	5/8	3/4	1
41BS12	23.60	12	2.17	.38	1/2	5/8	3/4	1
41BS13	24.40	13	2.33	.43	1/2	5/8	3/4	1
41BS14	25.80	14	2.49	.56	1/2	5/8	3/4	1
41BS15	28.00	15	2.65	.68	1/2	5/8	3/4	1
41BS16	29.80	16	2.81	.70		5/8	3/4	1
41BS17	32.00	17	2.97	1.00		5/8	3/4	1
41BS18	34.20	18	3.14	1.10		5/8	3/4	1
41BS19	37.40	19	3.29	1.30		5/8	3/4	1
41BS20	41.80	20	3.46	1.56		5/8	3/4	1
41BS21	46.20	21	3.62	1.68		5/8	3/4	1
41BS22	50.60	22	3.78	1.80		5/8	3/4	1
41BS23	55.60	23	3.94	2.10		5/8	3/4	1
41BS24	61.00	24	4.10	2.20		5/8	3/4	1

Hub diameters may vary to suit various bore sizes.
Harden per tooth\$ 0.94

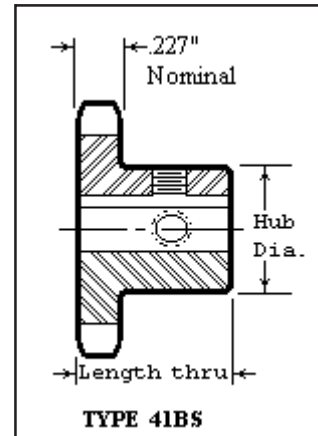

RYLE P/N	LIST PRICE	O.D. TEETH	MAX BORE	L1	L2	C	Y	G	X	T	LBS
41QD15JA	36.80	2.65	1-1/4	1-1/8	1-1/8	2-1/16	49/64	25/64	5/8	.227	.5
41QD16JA	37.80	2.81									.5
41QD17JA	41.00	2.98									.5
41QD18JA	48.00	3.14									.5
41QD19JA	53.80	3.30	1-1/4	1-1/8	1-1/8	2-1/16	49/64	25/64	5/8	.227	.6
41QD20SH	55.00	3.46	1-5/8	1-7/16	1-7/16	2-11/16	1-1/32	37/64	13/16	.227	.6
41QD21SH	56.60	3.62									.7
41QD22SH	62.40	3.78									.8
41QD23SH	68.00	3.94									.9
41QD24SH	71.60	4.10									1.0
41QD25SH	74.80	4.26									1.1
41QD26SH	79.20	4.42									1.2
41QD27SH	83.80	4.58									1.4
41QD28SH	84.60	4.74									1.5
41QD30SH	85.40	5.06									1.6
41QD32SH	94.40	5.38									1.7
41QD35SH	98.40	5.86	1-5/8	1-7/16	1-7/16	2-11/16	1-1/32	37/64	13/16	.227	1.8
41QD36SDS	98.80	6.02	2	1-1/2	1-1/2	3-3/16	1-3/32	17/32	3/4	.227	1.9
41QD40SDS	100.20	6.65									2.3
41QD42SDS	104.20	6.97									2.6
41QD45SDS	105.40	7.45									3.5
41QD48SDS	108.20	7.93									3.7
41QD54SDS	113.80	8.89									4.1
41QD60SDS	119.20	9.84	2	1-1/2	1-1/2	3-3/16	1-3/32	17/32	3/4	.227	5.4
41QD70SK	123.20	11.43	2-5/8	2-1/8	2-1/8	3-7/8	1-41/64	1-1/32	1-1/4	.227	8.1
41QD72SK	128.20	11.75									8.8
41QD80SK	142.40	13.03									10.4
41QD84SK	168.60	13.66									11.2
41QD96SK	228.20	15.57									15.7
41QD112SK	307.40	18.12	2-5/8	2-1/8	2-1/8	3-7/8	1-41/64	1-1/32	1-1/4	.227	16.0

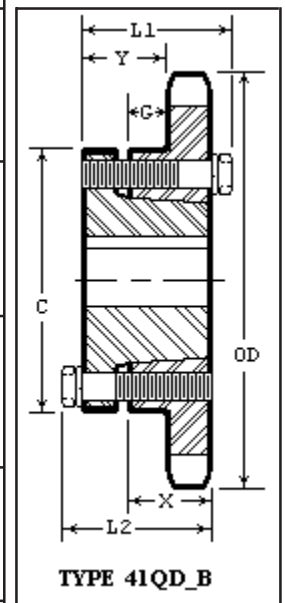

Harden per tooth\$ 0.94

QD Bushing dimensions and prices page 10



RYLE Manufacturing Company 1-800-433-0960

No. 40 1/2" Pitch

Type B

Type A

RYLE P/N	LIST PRICE	NO. TEETH	O.D. TEETH	STOCK BORE	MAX BORE	HUB DIA	LTB	LBS	RYLE P/N	LIST PRICE	LBS
40B8	17.40	8	1.50	1/2	1/2	31/32 *	7/8	.10			
40B9	18.20	9	1.67		5/8	1-1/16 *		.18			
40B10	18.60	10	1.84		3/4	1-1/4 *		.20			
40B11	20.40	11	2.00		13/16	1-7/16 *		.25			
40B12	21.80	12	2.17		15/16	1-9/16 *		.40	40A12	24.40	.26
40B13	22.20	13	2.33		1-1/16	1-9/16		.43	40A13	24.80	.30
40B14	22.20	14	2.49		1-1/8	1-11/16		.56	40A14	25.80	.34
40B15	22.20	15	2.65		1-1/4	1-13/16		.60	40A15	26.20	.38
40B16	23.20	16	2.81	5/8	1-3/8	2		.88	40A16	26.20	.42
40B17	27.20	17	2.98		1-7/16	2-1/8		1.00	40A17	27.20	.50
40B18	29.00	18	3.14		1-1/2	2-5/16		1.06	40A18	27.20	.54
40B19	33.00	19	3.30		1-3/4	2-1/2	1	1.30	40A19	27.20	.59
40B20	37.80	20	3.46		1-7/8	2-5/8	1	1.56	40A20	28.40	.66
40B21	41.80	21	3.62			2-3/4	1	1.68	40A21	29.00	.73
40B22	45.80	21	3.78			2-7/8	1	1.81	40A22	29.80	.79
40B23	50.40	23	3.94		2	3	1	2.18	40A23	30.20	.89
40B24	53.00	24	4.10		2-1/4	3-1/4	1	2.20	40A24	31.20	.95
40B25	55.60	25	4.26				1	2.37	40A25	31.60	1.01
40B26	58.20	26	4.42				1	2.40	40A26	32.40	1.07
40B27	61.40	27	4.58				1	2.50	40A27	33.00	1.12
40B28	63.60	28	4.74				1	2.75	40A28	33.80	1.26
40B29	64.80	29	4.90				1	2.81	40A29	34.20	1.32
40B30	65.80	30	5.06				1	2.87	40A30	35.20	1.39
40B31	66.40	31	5.22				1	2.90	40A31	35.60	1.45
40B32	67.20	32	5.38				1	3.00	40A32	36.60	1.53
40B33	69.00	33	5.54				1	3.15	40A33	37.80	1.68
40B34	69.80	34	5.70				1	3.30	40A34	38.20	1.84
40B35	70.40	35	5.86				1	3.50	40A35	38.20	1.92
40B36	71.60	36	6.02				1	3.70	40A36	39.20	2.00
40B37	72.80	37	6.18				1	3.75	40A37	40.40	2.10
40B38	74.80	38	6.33		2-3/8	3-1/2	1	3.80	40A38	42.20	2.18
40B39	76.40	39	6.49				1	3.90	40A39	42.20	2.27
40B40	78.00	40	6.65				1	4.00	40A40	43.20	2.36
40B41	79.20	41	6.81				1	4.10	41A41	44.40	2.54
40B42	79.60	42	6.97	3/4	2-1/2	3-3/4	1	4.20	40A42	45.00	2.73
40B43	80.00	43	7.13				1	4.30	40A43	46.20	2.88
40B44	80.40	44	7.29				1	4.40	40A44	47.20	3.00
40B45	80.60	45	7.45				1	4.50	40A45	47.60	3.13
40B46	82.00	46	7.61				1	4.75	40A46	48.60	3.24
40B47	85.00	47	7.77				1	5.00	40A47	49.80	3.35
40B48	85.80	48	7.93				1	5.12	40A48	50.40	3.50
40B49	87.60	49	8.09				1	5.20	40A49	51.60	3.65
40B50	89.80	50	8.25				1	5.27	40A50	53.00	3.80
40B51	90.20	51	8.41				1	5.50	40A51	54.20	4.00
40B52	90.60	52	8.57				1	5.60	40A52	55.20	4.20
40B53	91.00	53	8.73				1	6.00	40A53	55.60	4.35
40B54	91.20	54	8.89				1	6.20	40A54	56.60	4.50
40B55	92.00	55	9.04				1	6.30	40A55	57.00	4.65
40B56	93.20	56	9.20				1	6.40	40A56	58.20	4.80
40B57	94.00	57	9.36				1	6.60	40A57	59.60	4.95
40B58	95.20	58	9.52				1	6.80	40A58	61.80	5.10
40B59	95.80	59	9.68				1	7.00	40A59	63.20	5.20
40B60	96.60	60	9.84				1	7.20	40A60	63.60	5.30
40B70	113.80	70	11.43		2-3/4	4	1-1/4	10.00	40A70	75.60	7.40
40B72	118.40	72	11.75					12.00	40A72	78.20	7.70
40B80	138.40	80	13.03	1				13.00	40A80	96.60	9.40
40B84	150.40	84	13.66	1				14.00	40A84	105.00	10.10
40B96	200.60	96	15.57	1				20.00	40A96	134.00	13.40
40B112	267.40	112	18.12	1				25.00	40A112	187.40	18.00

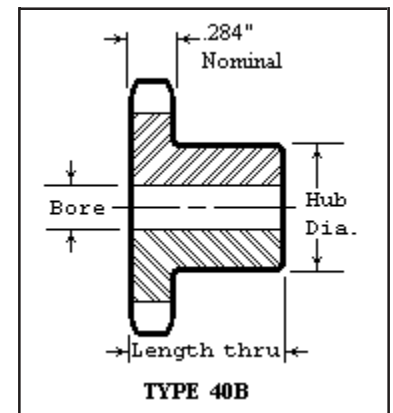
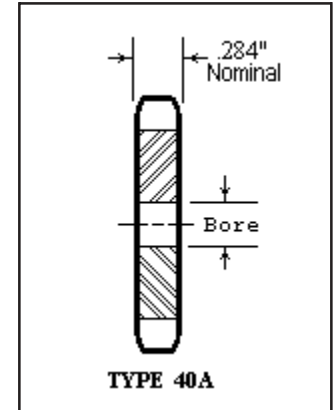

Split Type A plate \$ 2.76
per inch of sprocket diameter

Rebore \$49.00
Keyway \$13.40
Setscrew (each) \$13.40
Harden per tooth \$.94
Drill Type A plate (4) holes = \$28.00
(6) holes = \$42.00
(8) holes = \$56.00

* Indicates hub diameter is grooved for chain clearance. Maximum bores will accommodate standard keyway and setscrew over key. Slightly larger bores may be possible with shallow keyway and/or setscrew at 90 degrees. Multiple keyways must be priced at factory.



RYLE Manufacturing Company 1-800-433-0960

No. 40 1/2" Pitch Stainless Steel

Type B

Type A

RYLE P/N	LIST PRICE	NO. TEETH	O.D. TEETH	STOCK BORE	MAX BORE	HUB DIA	LTB	LBS	RYLE P/N	LIST PRICE	LBS
40B10SS	119.60	10	1.84	1/2	3/4	1-1/4 *	7/8	.20			
40B11SS	127.60	11	2.00		13/16	1-7/16 *		.25			
40B12SS	136.20	12	2.17		15/16	1-9/16 *		.40			
40B13SS	140.60	13	2.33		1-1/16	1-9/16		.43			
40B14SS	146.00	14	2.49		1-1/8	1-11/16		.56			
40B15SS	152.20	15	2.65		1-1/4	1-13/16		.60			
40B16SS	158.40	16	2.81	5/8	1-3/8	2		.88			
40B17SS	170.40	17	2.98		1-7/16	2-1/8		1.00			
40B18SS	182.40	18	3.14		1-1/2	2-5/16		1.06			
40B19SS	208.60	19	3.30		1-3/4	2-1/2	1	1.30			
40B20SS	238.60	20	3.46		1-7/8	2-5/8	1	1.56			
40B21SS	260.40	21	3.62			2-3/4	1	1.68			
40B22SS	284.80	22	3.78			2-7/8	1	1.81			
40B23SS	304.80	23	3.94		2	3	1	2.18			
40B24SS	331.40	24	4.10		2-1/4	3-1/4	1	2.20			
40B25SS	352.80	25	4.26				1	2.37	40A25SS	266.80	1.01
40B26SS	378.20	26	4.42				1	2.40	40A26SS	302.60	1.07
40B28SS	407.20	28	4.74				1	2.75	40A28SS	327.00	1.26
40B30SS	475.60	30	5.06				1	2.87	40A30SS	402.80	1.39
40B35SS	510.40	35	5.86				1	3.50	40A35SS	431.60	1.92
40B40SS	608.20	40	6.65				1	4.00	40A40SS	516.20	2.36
40B45SS	650.00	45	7.45	3/4			1	4.50	40A45SS	551.80	3.13
40B60SS	755.20	60	9.84				1	7.20	40A60SS	640.80	5.30

* Indicates hub diameter is grooved for chain clearance. Maximum bores will accommodate standard keyway and setscrew over key. Slightly larger bores may be possible with shallow keyway and/or setscrew at 90 degrees. Multiple keyways must be priced at factory.

Rebore	\$49.00	Drill Type A plate	(4) holes = \$28.00
Keyway	\$13.40		(6) holes = \$42.00
Setscrew (each)	\$13.40		(8) holes = \$56.00

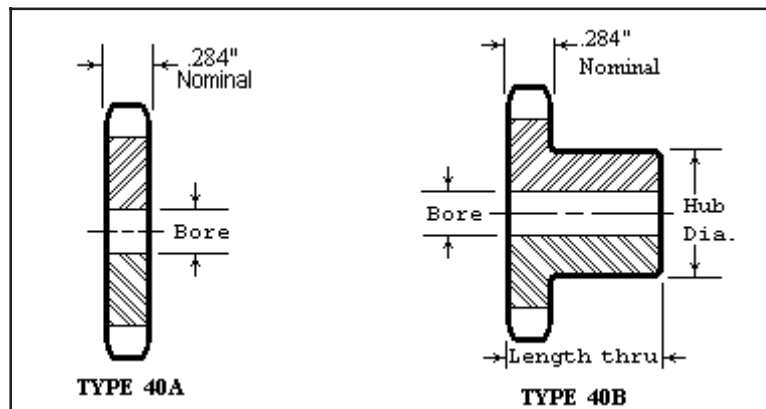



RYLE Manufacturing Company 1-800-433-0960

No. 40 1/2" Pitch Bored-to-Size

RYLE P/N	LIST PRICE	NO. TEETH	O.D. TEETH	LBS	AVAILABLE BORE SIZES WITH KEYWAY AND 2)SS															
40BS9	21.40	9	1.67	.18	1/2	5/8														
40BS10	22.20	10	1.84	.20	1/2	5/8	3/4													
40BS11	23.20	11	2.00	.25	1/2	5/8	3/4	7/8												
40BS12	25.40	12	2.17	.40	1/2	5/8	3/4	7/8	1											
40BS13	26.60	13	2.33	.43	1/2	5/8	3/4	7/8	1											
40BS14	28.00	14	2.49	.56	1/2	5/8	3/4	7/8	1											
40BS15	30.20	15	2.65	.60	1/2	5/8	3/4	7/8	1	1-1/8	1-3/16	1-1/4 *								
40BS16	32.00	16	2.81	.68		5/8	3/4	7/8	1	1-1/8	1-3/16	1-1/4								
40BS17	33.80	17	2.98	1.00		5/8	3/4	7/8	1	1-1/8	1-3/16	1-1/4								
40BS18	35.60	18	3.14	1.06		5/8	3/4	7/8	1	1-1/8	1-3/16	1-1/4	1-3/8	1-7/16	1-1/2 *					
40BS19	39.60	19	3.30	1.30		5/8	3/4	7/8	1	1-1/8	1-3/16	1-1/4	1-3/8	1-7/16	1-1/2					
40BS20	45.40	20	3.46	1.56		5/8	3/4	7/8	1	1-1/8	1-3/16	1-1/4	1-3/8	1-7/16	1-1/2					
40BS21	49.40	21	3.62	1.68		5/8	3/4	7/8	1	1-1/8	1-3/16	1-1/4	1-3/8	1-7/16	1-1/2					
40BS22	54.20	22	3.78	1.81		5/8	3/4	7/8	1	1-1/8	1-3/16	1-1/4	1-3/8	1-7/16	1-1/2					
40BS23	60.00	23	3.94	2.18		5/8	3/4	7/8	1	1-1/8	1-3/16	1-1/4	1-3/8	1-7/16	1-1/2					
40BS24	64.40	24	4.10	2.20		5/8	3/4	7/8	1	1-1/8	1-3/16	1-1/4	1-3/8	1-7/16	1-1/2					
40BS25	70.00	25	4.26	2.37		5/8	3/4	7/8	1	1-1/8	1-3/16	1-1/4	1-3/8	1-7/16	1-1/2					
40BS26	74.40	26	4.42	2.40		5/8	3/4	7/8	1	1-1/8	1-3/16	1-1/4	1-3/8	1-7/16	1-1/2					
40BS28	85.00	28	4.74	2.50		5/8	3/4	7/8	1	1-1/8	1-3/16	1-1/4	1-3/8	1-7/16	1-1/2					
40BS30	93.00	30	5.06	2.87		5/8	3/4	7/8	1	1-1/8	1-3/16	1-1/4	1-3/8	1-7/16	1-1/2					
40BS32	94.40	32	5.38	3.00		5/8	3/4	7/8	1	1-1/8	1-3/16	1-1/4	1-3/8	1-7/16	1-1/2					
40BS35	99.20	35	5.86	3.50		5/8	3/4	7/8	1	1-1/8	1-3/16	1-1/4	1-3/8	1-7/16	1-1/2					
40BS36	100.60	36	6.02	3.60		5/8	3/4	7/8	1	1-1/8	1-3/16	1-1/4	1-3/8	1-7/16	1-1/2					
40BS40	107.20	40	6.65	4.00		5/8	3/4	7/8	1	1-1/8	1-3/16	1-1/4	1-3/8	1-7/16	1-1/2					
40BS45	111.20	45	7.45	4.50			3/4	7/8	1	1-1/8	1-3/16	1-1/4	1-3/8	1-7/16	1-1/2					
40BS60	129.00	60	9.84	7.20			3/4	7/8	1	1-1/8	1-3/16	1-1/4	1-3/8	1-7/16	1-1/2					

* Indicates setscrew at 90 degrees to keyway
 Hub diameters may vary to suit bore sizes
 Harden per tooth.....\$.94

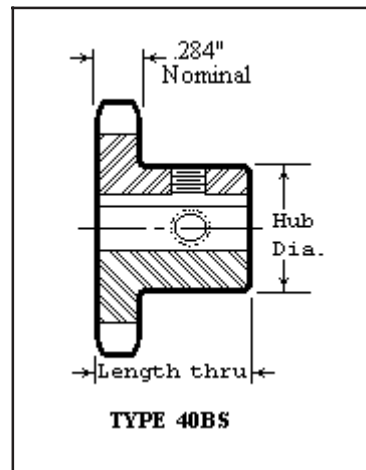

RYLE P/N	LIST PRICE
40BS9H	29.80
40BS10H	31.60
40BS11H	33.40
40BS12H	36.80
40BS13H	38.80
40BS14H	41.20
40BS15H	44.40
40BS16H	47.00
40BS17H	49.80
40BS18H	52.40
40BS19H	57.40
40BS20H	64.20
40BS21H	69.20
40BS22H	74.80
40BS23H	81.60
40BS24H	87.00
40BS25H	93.60
40BS26H	98.80
40BS28H	111.20
40BS30H	121.20

**Induction
 Hardened
 Teeth**



RYLE Manufacturing Company 1-800-433-0960

No. 40 1/2" Pitch

Type C

RYLE P/N	LIST PRICE	NO. TEETH	O.D. TEETH	STOCK BORE	MAX BORE	HUB DIA	LTB	LBS
40C12	82.00	12	2.17	1/2	3/4	1-39/64 *	1-1/2	.8
40C13	88.00	13	2.33		1-1/16	1-3/4		.9
40C14	89.40	14	2.49		1-1/8	1-11/16		.9
40C15	92.60	15	2.65		1-1/4	1-7/8		1.2
40C16	97.60	16	2.81		1-3/8	2-1/16		1.3
40C17	103.00	17	2.98	5/8	1-7/16	2-1/8		1.5
40C18	112.60	18	3.14		1-1/2	2-3/8		1.8

* Indicates hub is grooved for chain clearance.

Rebore	\$49.00
Keyway	\$13.40
Setscrew (each)	\$13.40
Harden per Tooth	\$ 0.94

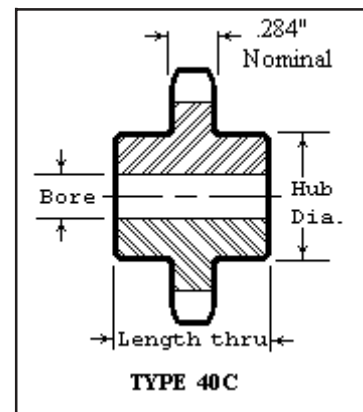

RYLE P/N	LIST PRICE	NO. TEETH	O.D. TEETH	W	B	L	LBS
40BB17H	56.80	17	2.98	0.284	5/8	.720	.52

BB = Sealed Ball Bearing

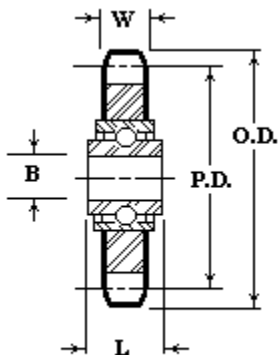

Type B Hard Teeth

RYLE P/N	LIST PRICE
40B8H	24.80
40B9H	26.60
40B10H	28.20
40B11H	30.80
40B12H	33.00
40B13H	34.40
40B14H	35.40
40B15H	36.40
40B16H	38.20
40B17H	43.00
40B18H	45.80
40B19H	50.80
40B20H	56.60
40B21H	61.60
40B22H	66.40
40B23H	72.00
40B24H	75.40
40B25H	80.00

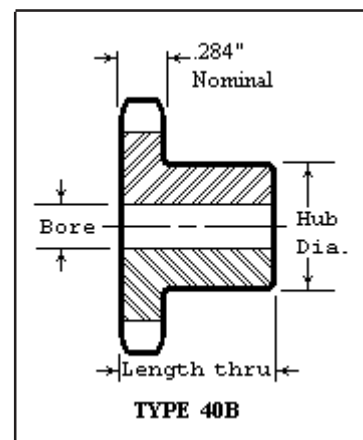

Double-Single

RYLE P/N	LIST PRICE	TEETH O.D.	STOCK BORE	MAX BORE	LTB	HUB DIA	LBS
DS40A15	78.00	2.65	1/2	1-1/4	1-13/32	1-13/16	1.2
DS40A16	82.40	2.81				2	1.4
DS40A17	89.00	2.98		1-5/16		2-9/64	1.6
DS40A18	93.40	3.14	1/2	1-1/2		2-5/16	1.8
DS40A19	102.40	3.30	5/8	1-11/16		2-1/2	2.1
DS40A20	109.00	3.46		1-3/4		2-5/8	2.6
DS40A21	113.40	3.62		1-13/16		2-25/32	2.9
DS40A22	122.40	3.78		1-15/16		2-15/16	3.0
DS40A23	129.00	3.94		2-1/16		3-3/32	3.5
DS40A24	138.00	4.10	5/8	2-1/4	1-13/32	3-17/64	4.0

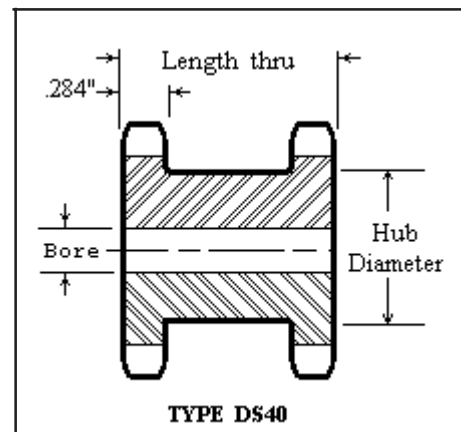



RYLE Manufacturing Company 1-800-433-0960

No. 40 1/2" Pitch

RYLE P/N	LIST PRICE	O.D. TEETH	MAX BORE	L1	L2	C	Y	G	X	T	LBS
40QD15JA	37.80	2.65	1-1/4	1-1/8	1-1/8	2-1/16	23/32	11/32	5/8	.284	.4
40QD16JA	39.60	2.81									.6
40QD17JA	43.20	2.98									.6
40QD18JA	46.20	3.14									.7
40QD19JA	49.40	3.30	1-1/4	1-1/8	1-1/8	2-1/16	23/32	11/32	5/8	.284	.7
40QD20SH	53.40	3.46	1-5/8	1-7/16	1-7/16	2-11/16	31/32	17/32	13/16	.284	.8
40QD21SH	57.80	3.62									.9
40QD22SH	65.00	3.78									1.0
40QD23SH	69.40	3.94									1.1
40QD24SH	73.00	4.10									1.2
40QD25SH	77.40	4.26									1.3
40QD26SH	81.00	4.42									1.5
40QD27SH	82.80	4.58									1.7
40QD28SH	85.40	4.74									1.8
40QD30SH	88.20	5.06									2.0
40QD32SH	97.40	5.38									2.1
40QD35SH	100.60	5.86	1-5/8	1-7/16	1-7/16	2-11/16	31/32	17/32	13/16	.284	2.2
40QD36SDS	101.00	6.02	2	1-1/2	1-1/2	3-3/16	1-1/32	15/32	3/4	.284	2.3
40QD40SDS	111.20	6.65									2.4
40QD42SDS	113.40	6.97									2.8
40QD45SDS	115.60	7.45									3.3
40QD48SDS	120.60	7.93									4.5
40QD54SDS	126.80	8.89									5.1
40QD60SDS	132.60	9.84	2	1-1/2	1-1/2	3-3/16	1-1/32	15/32	3/4	.284	6.6
40QD70SK	134.80	11.43	2-5/8	2-1/8	2-1/8	3-7/8	1-19/32	31/32	1-1/4	.284	9.8
40QD72SK	135.80	11.75									10.6
40QD80SK	150.80	13.03									12.7
40QD84SK	162.00	13.66									13.7
40QD96SK	248.80	15.57									18.7
40QD112SK	288.00	18.12	2-5/8	2-1/8	2-1/8	3-7/8	1-19/32	31/32	1-1/4	.284	20.0

Harden per tooth\$ 0.94

QD Bushing dimensions and prices page 10

RYLE P/N	LIST PRICE
40QD15HJA	50.40
40QD16HJA	52.00
40QD17HJA	56.00
40QD18HJA	60.60
40QD19HJA	61.40
40QD20HSH	61.80
40QD21HSH	74.80
40QD22HSH	82.80
40QD23HSH	88.20
40QD24HSH	92.00
40QD25HSH	97.40
40QD26HSH	101.40
40QD27HSH	104.20
40QD28HSH	107.60
40QD30HSH	112.60

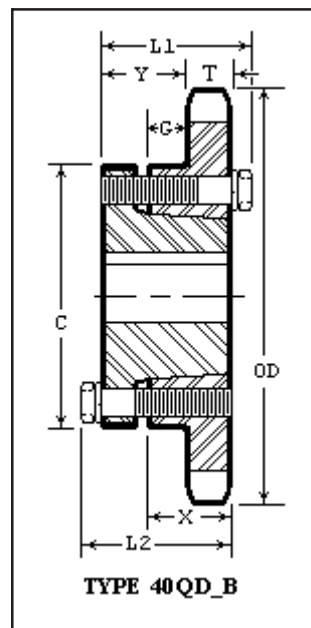



RYLE Manufacturing Company 1-800-433-0960

No. 40-2 Double Strand 1/2" Pitch

RYLE P/N	LIST PRICE	NO. TEETH	O.D. TEETH	STOCK BORE	MAX BORE	HUB DIA	LTB	LBS
D40B11H	68.60	11	2.00	1/2	3/4	1-7/16*	1-1/2	.6
D40B12H	69.00	12	2.17		15/16	1-9/16*		.7
D40B13H	69.80	13	2.33		1	1-1/2		.8
D40B14H	71.20	14	2.49		1-1/8	1-11/16		1.1
D40B15H	71.20	15	2.65		1-1/4	1-13/16		1.2
D40B16H	71.60	16	2.81	5/8	1-3/8	2		1.4
D40B17H	73.80	17	2.98		1-7/16	2-1/8		1.6
D40B18H	78.00	18	3.14		1-1/2	2-3/8		1.8
D40B19H	81.80	19	3.30		1-3/4	2-1/2		2.0
D40B20H	87.20	20	3.46		1-7/8	2-5/8	1-5/8	2.4
D40B21H	91.20	21	3.62		1-7/8	2-3/4		2.8
D40B22H	94.80	22	3.78			2-7/8		3.0
D40B23H	101.00	23	3.94		2	3		3.2
D40B24H	106.40	24	4.10		2-1/4	3-1/4		3.4
D40B25H	109.00	25	4.26					3.8
D40B26	109.00	26	4.42					4.5
D40B30	111.20	30	5.06	3/4				5.1
D40B35	129.00	35	5.86					6.5
D40B36	138.40	36	6.02		2-1/2	3-3/4		7.2
D40B40	153.20	40	6.65				1-3/4	9.4
D40B42	159.80	42	6.97					10.2
D40B45	190.00	45	7.45					11.4
D40B48	198.00	48	7.93					12.7
D40B52	220.20	52	8.57					14.5
D40B54	228.60	54	8.89					15.5
D40B60	235.40	60	9.84					18.6
D40B68	247.40	68	11.12	1	2-3/4	4-1/4	2-1/8	25.0
D40B72	287.40	72	11.75	1				27.9
D40B76	307.40	76	12.39	1				30.2
D40B84	338.20	84	13.66	1				36.2
D40B95	399.60	95	15.41	1				38.8
D40B96	415.20	96	15.57	1				39.5
D40B102	438.80	102	16.53	1				42.7
D40B112	461.80	112	18.12	1				55.5

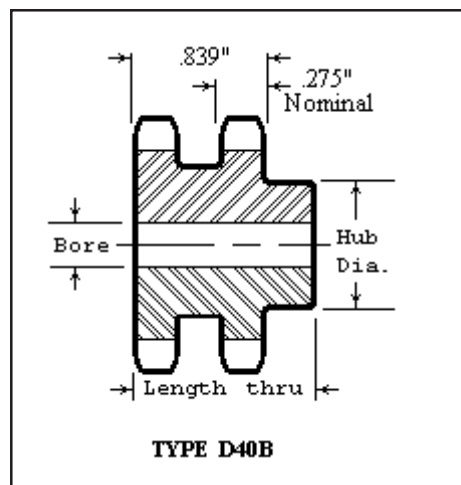

Rebore	\$49.00
Keyway	\$13.40
Setscrew (each)	\$13.40
Harden per tooth	\$.94

* Indicates hub diameter is grooved for chain clearance. Maximum bores will accommodate standard keyway and setscrew over key. Slightly larger bores may be possible with shallow keyway and/or setscrew at 90 degrees. Multiple keyways must be priced at factory. Note: 25 teeth or less already have Hardened Teeth.

RYLE P/N	LIST PRICE	O.D. TEETH	MAX BORE	L1	L2	C	Y	X	W	P	T	LBS
D40QD36SK	181.00	6.02	2-5/8	2-1/8		3-7/8	5/8	1-1/4	.839	13/32	.275	7.0
D40QD40SK	181.60	6.85										9.0
D40QD42SK	182.40	6.97										11.0
D40QD45SK	240.60	7.45										12.0
D40QD48SK	250.00	7.93										14.0
D40QD52SK	258.60	8.57										15.0
D40QD54SK	267.80	8.89										17.0
D40QD60SK	292.80	9.84	2-5/8	2-1/8		3-7/8	5/8	1-1/4	.839	13/32	.275	21.0
D40QD68SF	297.60	11.12	2-15/16	2-1/4		4-5/8	3/4	1-1/4	.839	13/32	.275	25.0
D40QD72SF	340.80	11.75										27.0
D40QD76SF	367.20	12.39										29.0
D40QD84SF	403.20	13.66										33.0
D40QD95SF	474.40	15.41										38.0
D40QD102SF	519.40	16.53										41.0
D40QD112SF	794.20	18.12	2-15/16	2-1/4		4-5/8	3/4	1-1/4	.839	13/32	.275	46.0

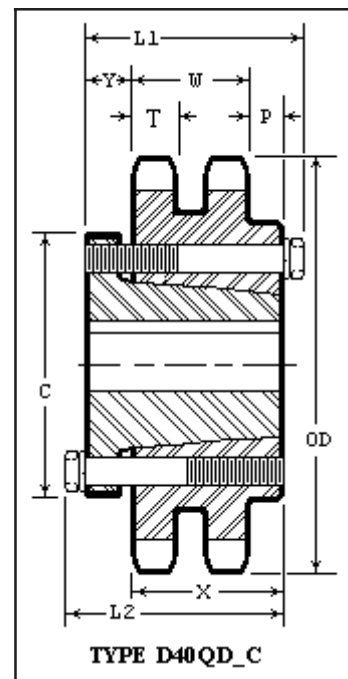

Hardened per tooth\$ 0.94
 QD Bushing dimensions and prices page 10



RYLE Manufacturing Company 1-800-433-0960

No. 40-3 Triple Strand 1/2" Pitch

RYLE P/N	LIST PRICE	NO. TEETH	O.D. TEETH	STOCK BORE	MAX BORE	HUB DIA	LTB	LBS
E40B11H	103.20	11	2.00	1/2	3/4	1-7/16 *	2-1/8	.8
E40B12H	104.60	12	2.17		15/16	1-9/16 *		1.1
E40B13H	105.00	13	2.33		1	1-1/2		1.3
E40B14H	105.00	14	2.49		1-1/8	1-11/16		1.6
E40B15H	105.80	15	2.65		1-1/4	1-13/16		1.8
E40B16H	108.60	16	2.81	5/8	1-3/8	2		2.0
E40B17H	113.80	17	2.98		1-7/16	2-1/8		2.3
E40B18H	120.60	18	3.14		1-1/2	2-3/8		2.7
E40B19H	126.40	19	3.30		1-3/4	2-1/2		3.1
E40B20H	134.00	20	3.46		1-7/8	2-5/8	2-1/4	3.5
E40B21H	142.00	21	3.62		1-7/8	2-3/4		4.0
E40B22H	149.00	22	3.78			2-7/8		4.5
E40B23H	156.60	23	3.94		2	3		5.0
E40B24H	164.60	24	4.10		2-1/4	3-1/4		5.4
E40B25H	168.60	25	4.26					5.6
E40B26	168.60	26	4.42					6.3
E40B30	174.00	30	5.06	3/4				7.7
E40B35	191.80	35	5.86					10.1
E40B36	210.40	36	6.02		2-1/2	3-3/4	2-3/8	11.7
E40B42	224.80	42	6.97					15.4
E40B48	243.40	48	7.93					19.4
E40B52	259.40	52	8.57					22.4
E40B60	292.80	60	9.84					30.0
E40B68	322.20	68	11.12	1	2-3/4	4-1/4	2-5/8	38.5
E40B72	361.80	72	11.75	1				42.5
E40B76	381.80	76	12.39	1				46.9
E40B84	423.20	84	13.66	1				57.3
E40B95	492.60	95	15.41	1			2-3/4	62.2
E40B102	591.00	102	16.53	1				68.4

* Indicates hub diameter is grooved for chain clearance. Note: 25 teeth or less already have Hardened Teeth. Maximum bores will accommodate standard keyway and setscrew over key.

Rebore	\$49.00
Keyway	\$13.40
Setscrew (each)	\$13.40
Harden per tooth	\$.94

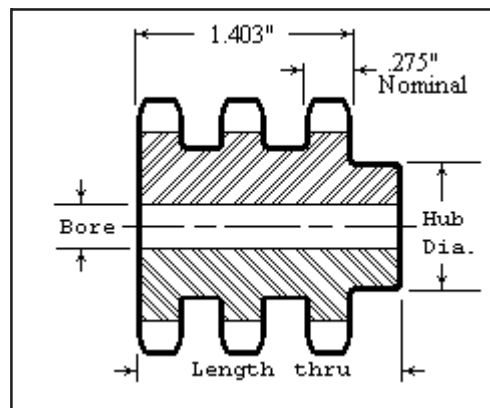



RYLE Manufacturing Company 1-800-433-0960

No. 40-3 Triple Strand 1/2" Pitch

RYLE P/N	LIST PRICE	O.D. TEETH	MAX BORE	L1		C	DIMENSIONS		W	P	T	LBS
				L2			Y	X				
E40QD36SK	264.80	6.02	2-5/8	2-1/8		3-7/8	15/32	1-1/4	1.403	13/32	.275	6.0
E40QD42SK	281.20	6.97										10.0
E40QD48SK	303.00	7.93										13.0
E40QD52SK	321.80	8.57										16.0
E40QD60SK	360.40	9.84	2-5/8	2-1/8		3-7/8	15/32	1-1/4	1.403	13/32	.275	23.0
E40QD68SF	384.00	11.12	2-15/16	2-1/4		4-5/8	19/32	1-1/4	1.403	13/32	.275	30.0
E40QD72SF	429.80	11.75										34.0
E40QD76SF	453.40	12.39										49.0
E40QD84SF	502.60	13.66										54.0
E40QD95SF	582.40	15.41										56.0
E40QD102SF	696.40	16.53	2-15/16	2-1/4		4-5/8	19/32	1-1/4	1.403	13/32	.275	59.0

Harden per tooth\$ 0.94

QD Bushing dimensions and prices page 10

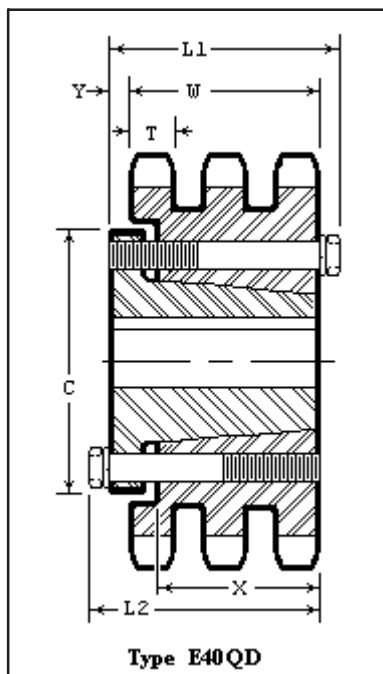



RYLE Manufacturing Company 1-800-433-0960

No. 50 5/8" Pitch

Type B

Type A

RYLE P/N	LIST PRICE	NO. TEETH	O.D. TEETH	STOCK BORE	MAX BORE	HUB DIA	LTB	LBS	RYLE P/N	LIST PRICE	LBS
50B8	24.40	8	1.88	5/8	5/8	1-1/8 *	1	.25			
50B9	24.80	9	2.09		3/4	1-3/8 *	1	.30			
50B10	27.20	10	2.30		7/8	1-9/16*	1	.50			
50B11	29.00	11	2.50		1	1-3/4 *	1	.60	50A11	29.00	.25
50B12	30.20	12	2.71		1-1/4	1-7/8 *	1	.70	50A12	29.00	.33
50B13	31.60	13	2.91		1-5/16	1-15/16*	1	.80	50A13	29.00	.42
50B14	33.00	14	3.11		1-7/16	2	1	1.0	50A14	29.00	.70
50B15	34.20	15	3.32		1-1/2	2-1/4	1	1.3	50A15	29.80	.80
50B16	36.80	16	3.52		1-3/4	2-1/2	1	1.5	50A16	30.20	.90
50B17	39.60	17	3.72		1-7/8	2-11/16	1	1.8	50A17	31.20	1.0
50B18	43.20	18	3.92		1-7/8	2-7/8	1	2.0	50A18	31.60	1.1
50B19	45.80	19	4.12		2	3	1	2.3	50A19	32.40	1.2
50B20	51.20	20	4.32	3/4			1	2.5	50A20	33.00	1.3
50B21	55.60	21	4.52				1	2.6	50A21	33.80	1.4
50B22	59.60	22	4.72				1	2.8	50A22	35.20	1.6
50B23	63.60	23	4.92				1	3.2	50A23	36.60	1.7
50B24	67.20	24	5.12			3-1/4	1-1/4	4.0	50A24	36.80	1.8
50B25	72.60	25	5.32					4.3	50A25	37.80	1.9
50B26	75.20	26	5.52					4.5	50A26	39.60	2.1
50B27	78.00	27	5.72					4.8	50A27	41.00	2.3
50B28	78.20	28	5.92					4.8	50A28	41.80	2.5
50B29	79.60	29	6.12					5.1	50A29	43.20	2.6
50B30	80.60	30	6.32		2-3/8	3-1/2		5.2	50A30	43.60	2.7
50B31	83.20	31	6.52					5.3	50A31	45.80	2.9
50B32	83.60	32	6.72					5.5	50A32	46.20	3.1
50B33	87.20	33	6.92					5.6	50A33	49.00	3.4
50B34	87.60	34	7.12					5.8	50A34	49.80	3.5
50B35	88.60	35	7.32					6.3	50A35	50.40	3.7
50B36	89.80	36	7.52					6.7	50A36	51.60	3.9
50B37	93.40	37	7.72					6.8	50A37	53.00	4.2
50B38	95.60	38	7.92					7.0	50A38	54.20	4.5
50B39	96.60	39	8.12					7.3	50A39	55.20	4.6
50B40	97.00	40	8.32					7.8	50A40	55.60	4.7
50B41	98.00	41	8.52					7.9	50A41	56.60	5.0
50B42	99.60	42	8.72					8.0	50A42	57.80	5.3
50B43	100.60	43	8.91					8.2	50A43	59.60	5.5
50B44	103.20	44	9.11					8.3	50A44	61.80	5.7
50B45	103.60	45	9.31					8.5	50A45	62.40	6.0
50B46	105.20	46	9.51	1	2-1/2	3-3/4		8.8	50A46	63.60	6.3
50B47	107.60	47	9.71	1				9.0	50A47	65.00	6.6
50B48	109.00	48	9.91	1				9.5	50A48	65.80	7.0
50B49	115.60	49	10.11	1				9.8	50A49	67.60	7.2
50B50	118.00	50	10.31	1				10.0	50A50	70.40	7.5
50B51	118.60	51	10.51	1				10.2	50A51	73.00	7.7
50B52	119.20	52	10.71	1				10.5	50A52	73.80	8.0
50B53	120.00	53	10.91	1				10.8	50A53	74.40	8.2
50B54	120.60	54	11.11	1				11.2	50A54	75.20	8.4
50B55	122.80	55	11.31	1				11.5	50A55	80.60	8.8
50B56	125.20	56	11.50	1				12.8	50A56	85.80	9.2
50B57	127.00	57	11.70	1				13.1	50A57	85.80	9.6
50B58	128.80	58	11.90	1				13.4	50A58	86.40	10.0
50B59	131.20	59	12.10	1				13.6	50A59	86.40	10.4
50B60	135.20	60	12.30	1				14.0	50A60	87.20	10.8
50B70	183.40	70	14.29	1			1-3/4	17.0	50A70	111.80	14.0
50B72	192.60	72	14.69	1				18.0	50A72	117.00	15.0
50B76	213.40	76	15.49	1				21.0	50A76	130.20	16.5
50B80	234.00	80	16.28	1	2-3/4	4-1/4		24.0	50A80	143.20	18.0
50B84	254.20	84	17.08	1				27.0	50A84	154.40	20.0
50B96	314.20	96	19.47	1				33.0	50A96	200.60	26.5
50B112	394.20	112	22.65	1				44.0	50A112	280.80	35.0

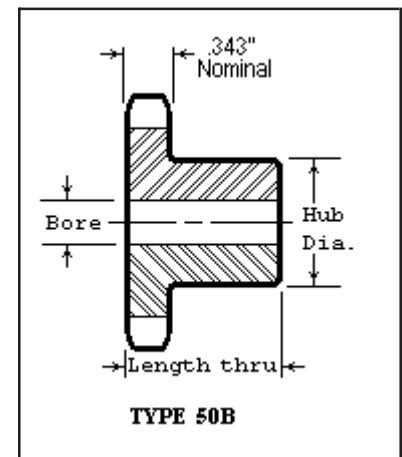
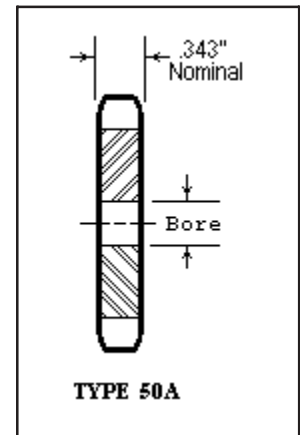

Split Type A plate	\$ 2.76
per inch of sprocket diameter	
Rebore	\$49.00
Keyway	\$13.40
Setscrew (each)	\$13.40
Harden per tooth	\$ 1.02
Drill Type A plate	(4) holes = \$28.00
	(6) holes = \$42.00
	(8) holes = \$56.00

* Indicates hub diameter is grooved for chain clearance. Maximum bores will accommodate standard keyway and setscrew over key. Slightly larger bores may be possible with shallow keyway and/or setscrew at 90 degrees. Multiple keyways must be priced at factory.



RYLE Manufacturing Company 1-800-433-0960

No. 50 5/8" Pitch Stainless Steel

Type B

Type A

RYLE P/N	LIST PRICE	NO. TEETH	O.D. TEETH	STOCK BORE	MAX BORE	HUB DIA	LTB	LBS	RYLE P/N	LIST PRICE	LBS			
50B10SS	170.40	10	2.30	5/8	7/8	1-9/16 *	1	.50	50A16SS	198.90	.90			
50B11SS	183.40	11	2.50		1	1-3/4 *	1	.60						
50B12SS	191.80	12	2.71		1-1/4	1-7/8 *	1	.70						
50B13SS	200.60	13	2.91		1-5/16	1-7/8	1	.80						
50B14SS	208.60	14	3.11		1-7/16	2	1	1.0						
50B15SS	217.20	15	3.32		1-1/2	2-1/4	1	1.3						
50B16SS	234.00	16	3.52		1-3/4	2-1/2	1	1.5						
50B17SS	251.40	17	3.72		1-7/8	2-11/16	1	1.8						
50B18SS	273.60	18	3.92		1-7/8	2-7/8	1	2.0						
50B19SS	291.80	19	4.12		2	3	1	2.3						
50B20SS	334.40	20	4.32	3/4			1	2.5						
50B21SS	382.60	21	4.52				1	2.6						
50B22SS	440.60	22	4.72				1	2.8						
50B23SS	487.20	23	4.92				1	3.2						
50B24SS	531.80	24	5.12			3-1/4	1-1/4	4.0						
50B25SS	583.80	25	5.32					4.3				50A26SS	489.40	2.1
50B26SS	611.80	26	5.52					4.5				50A28SS	505.00	2.5
50B28SS	631.80	28	5.92					4.8				50A30SS	528.40	2.7
50B30SS	675.00	30	6.32		2-3/8	3-1/2		5.2				50A35SS	547.20	3.7
50B35SS	729.80	35	7.32					6.3						
50B40SS	802.80	40	8.32					7.8	50A40SS	602.00	4.7			
50B45SS	875.60	45	9.31					8.5	50A45SS	656.80	6.0			
50B60SS	1094.20	60	12.30	1	2-1/2	3-3/4		14.0	50A60SS	820.60	10.8			

* Indicates hub diameter is grooved for chain clearance. Maximum bores will accommodate standard keyway and setscrew over key. Slightly larger bores may be possible with shallow keyway and/or setscrew at 90 degrees. Multiple keyways must be priced at factory.

Split Type A plate	\$ 2.76 per inch of sprocket diameter	Drill Type A plate	(4) holes = \$28.00
Rebore	\$49.00		(6) holes = \$42.00
Keyway	\$13.40		(8) holes = \$56.00
Setscrew (each)	\$13.40		

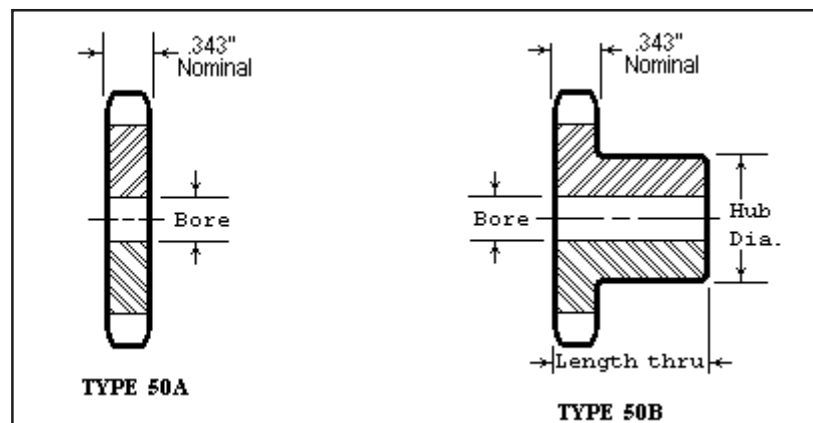



RYLE Manufacturing Company 1-800-433-0960

No. 50 5/8" Pitch Bored-to-Size

RYLE P/N	LIST PRICE	O.D. TEETH	LBS	AVAILABLE BORE SIZES WITH KEYWAY AND 2)SS *														
50BS9	29.40	2.09	.3	5/8	3/4 *													
50BS10	31.60	2.30	.5	5/8	3/4	7/8	1 *											
50BS11	33.00	2.50	.6	5/8	3/4	7/8	1											
50BS12	34.20	2.71	.6	5/8	3/4	7/8	1	1-1/8	1-3/16	1-1/4								
50BS13	35.60	2.91	.8	5/8	3/4	7/8	1	1-1/8	1-3/16	1-1/4								
50BS14	37.80	3.11	1.0	5/8	3/4	7/8	1	1-1/8	1-3/16	1-1/4								
50BS15	39.60	3.32	1.2	5/8	3/4	7/8	1	1-1/8	1-3/16	1-1/4	1-3/8	1-7/16	1-1/2					
50BS16	41.80	3.52	1.5	5/8	3/4	7/8	1	1-1/8	1-3/16	1-1/4	1-3/8	1-7/16	1-1/2					
50BS17	46.80	3.72	1.7	5/8	3/4	7/8	1	1-1/8	1-3/16	1-1/4	1-3/8	1-7/16	1-1/2	1-5/8				
50BS18	52.00	3.92	2.0	5/8	3/4	7/8	1	1-1/8	1-3/16	1-1/4	1-3/8	1-7/16	1-1/2	1-5/8				
50BS19	57.80	4.12	2.2	5/8	3/4	7/8	1	1-1/8	1-3/16	1-1/4	1-3/8	1-7/16	1-1/2	1-5/8				
50BS20	62.80	4.32	2.5	5/8	3/4	7/8	1	1-1/8	1-3/16	1-1/4	1-3/8	1-7/16	1-1/2	1-5/8				
50BS21	75.60	4.52	2.6		3/4	7/8	1	1-1/8	1-3/16	1-1/4	1-3/8	1-7/16	1-1/2					
50BS22	81.80	4.72	2.8		3/4	7/8	1	1-1/8	1-3/16	1-1/4	1-3/8	1-7/16	1-1/2					
50BS23	88.20	4.92	3.2		3/4	7/8	1	1-1/8	1-3/16	1-1/4	1-3/8	1-7/16	1-1/2					
50BS24	96.20	5.12	4.0		3/4	7/8	1	1-1/8	1-3/16	1-1/4	1-3/8	1-7/16	1-1/2					
50BS25	101.40	5.32	4.3		3/4	7/8	1	1-1/8	1-3/16	1-1/4	1-3/8	1-7/16	1-1/2					
50BS26	105.00	5.52	4.5		3/4	7/8	1	1-1/8	1-3/16	1-1/4	1-3/8	1-7/16	1-1/2					
50BS27		5.72	4.7		3/4	7/8	1	1-1/8	1-3/16	1-1/4	1-3/8	1-7/16	1-1/2					
50BS28	108.60	5.92	4.8		3/4	7/8	1	1-1/8	1-3/16	1-1/4	1-3/8	1-7/16	1-1/2					
50BS29		6.12	5.1		3/4	7/8	1	1-1/8	1-3/16	1-1/4	1-3/8	1-7/16	1-1/2					
50BS30	111.20	6.32	5.2		3/4	7/8	1	1-1/8	1-3/16	1-1/4	1-3/8	1-7/16	1-1/2					
50BS31	113.20	6.52	5.3		3/4	7/8	1	1-1/8	1-3/16	1-1/4	1-3/8	1-7/16	1-1/2	1-3/4	1-15/16			
50BS32	114.60	6.72	5.5		3/4	7/8	1	1-1/8	1-3/16	1-1/4	1-3/8	1-7/16	1-1/2	1-3/4	1-15/16			
50BS33	116.80	6.92	5.6		3/4	7/8	1	1-1/8	1-3/16	1-1/4	1-3/8	1-7/16	1-1/2	1-3/4	1-15/16			
50BS34		7.12	5.8		3/4	7/8	1	1-1/8	1-3/16	1-1/4	1-3/8	1-7/16	1-1/2	1-3/4	1-15/16			
50BS35	120.20	7.32	6.5		3/4	7/8	1	1-1/8	1-3/16	1-1/4	1-3/8	1-7/16	1-1/2	1-3/4	1-15/16			
50BS36	123.40	7.52	6.6		3/4	7/8	1	1-1/8	1-3/16	1-1/4	1-3/8	1-7/16	1-1/2	1-3/4	1-15/16			
50BS40	130.00	8.32	7.8		3/4	7/8	1	1-1/8	1-3/16	1-1/4	1-3/8	1-7/16	1-1/2	1-3/4	1-15/16			
50BS45	137.60	9.31	8.5		3/4	7/8	1	1-1/8	1-3/16	1-1/4	1-3/8	1-7/16	1-1/2	1-3/4	1-15/16			
50BS54	157.20	11.11	10.8				1	1-1/8	1-3/16	1-1/4	1-3/8	1-7/16	1-1/2	1-3/4	1-15/16			
50BS60	173.60	12.30	14.0				1	1-1/8	1-3/16	1-1/4	1-3/8	1-7/16	1-1/2	1-3/4	1-15/16			

* Indicates setscrew is at 90 degrees to keyway only.

Hub diameters may vary to suit bore sizes.

RYLE P/N	LIST PRICE
50BS9H	38.60
50BS10H	42.00
50BS11H	44.20
50BS12H	46.40
50BS13H	49.00
50BS14H	52.20
50BS15H	55.00
50BS16H	58.40
50BS17H	64.20
50BS18H	70.60
50BS19H	77.40
50BS20H	83.40
50BS21H	97.20
50BS22H	104.40
50BS23H	112.60
50BS24H	120.80

**Induction
Hardened
Teeth**

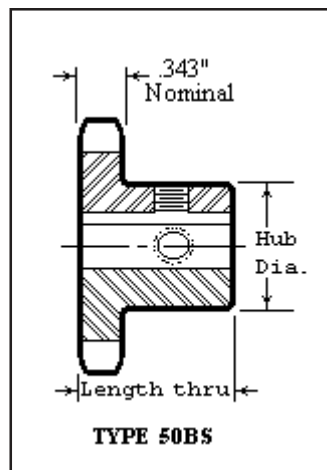



RYLE Manufacturing Company 1-800-433-0960

No. 50 5/8" Pitch

Type C

RYLE P/N	LIST PRICE	NO. TEETH	O.D. TEETH	STOCK BORE	MAX BORE	HUB DIA	LTB	LBS.
50C12	96.40	12	2.708	5/8	1-1/4	2 *	1-5/8	1.3
50C13	99.00	13	2.911		1-5/16	1-15/16		1.5
50C14	102.60	14	3.113		1-7/16	2-1/8		1.7
50C15	111.80	15	3.315		1-1/2	2-3/8		1.9
50C16	119.60	16	3.517		1-3/4	2-1/2		2.4
50C17	124.80	17	3.719		1-7/8	2-3/4		2.8
50C18	132.00	18	3.920		1-7/8	2-15/16		3.3
50C19	142.00	19	4.120	5/8	2	3-1/8	1-5/8	3.9

* Indicates hub diameter is grooved for chain clearance.

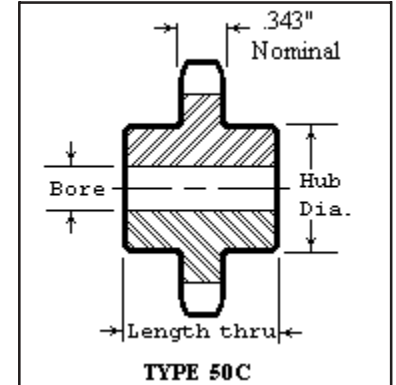

Type B Hard Teeth

RYLE P/N	LIST PRICE	NO. TEETH	O.D. TEETH	W	B	L	LBS.
50BB15H	58.20	15	3.32	0.343	5/8	.720	.75

BB = Sealed Ball Beas

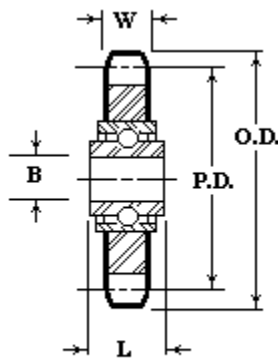

RYLE P/N	LIST PRICE
50B9H	34.20
50B10H	37.40
50B11H	40.20
50B12H	42.60
50B13H	45.00
50B14H	47.40
50B15H	49.60
50B16H	53.40
50B17H	57.00
50B18H	61.60
50B19H	65.40
50B20H	71.60
50B21H	77.20
50B22H	82.20
50B23H	87.00
50B24H	91.80

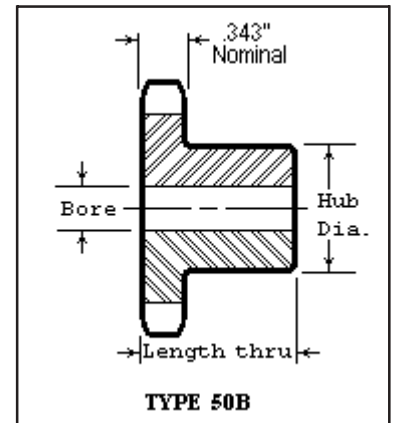

Double-Single

RYLE P/N	LIST PRICE	TEETH O.D.	STOCK BORE	MAX BORE	LTB	HUB DIA	LBS.
DS50A15	111.20	3.32	5/8	1-1/2	1-21/32	2-3/8	2.1
DS50A16	122.40	3.52		1-11/16		2-1/2	2.4
DS50A17	133.40	3.72		1-3/4		2-11/16	2.9
DS50A18	149.00	3.92		1-7/8		2-57/64	3.3
DS50A19	153.40	4.12		2-1/16		2-5/64	3.7
DS50A20	162.40	4.32		2-1/4		3-9/32	4.2
DS50A21	164.60	4.52		2-1/4		3-31/64	4.8
DS50A22	171.40	4.72		2-7/16		3-11/16	5.3
DS50A23	178.00	4.92		2-5/8		3-57/64	5.8
DS50A24	186.80	5.12	5/8	2-3/4	1-21/32	4-5/64	6.3

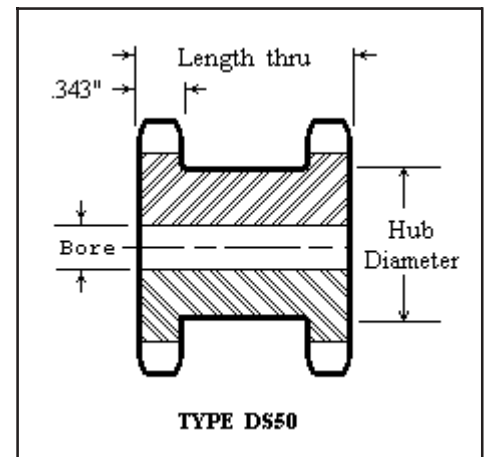



RYLE Manufacturing Company 1-800-433-0960

No. 50 5/8" Pitch

RYLE P/N	LIST PRICE	O.D. TEETH	MAX BORE	L1 L2	C	Y	G	X	T	LBS.
50QD12JA	43.20	2.71	1-1/4	1-1/8	2-1/16	21/32	9/32	5/8	.343	.6
50QD13JA	49.40	2.91								.6
50QD14JA	50.60	3.11								.8
50QD15JA	53.40	3.32								.8
50QD16JA	54.80	3.52	1-1/4	1-1/8	2-1/16	21/32	9/32	5/8	.343	.9
50QD17SH	57.80	3.72	1-5/8	1-7/16	2-11/16	29/32	15/32	13/16	.343	.9
50QD18SH	62.40	3.92								1.0
50QD19SH	65.80	4.12	1-5/8	1-7/16	2-11/16	29/32	15/32	13/16	.343	1.4
50QD20SDS	67.20	4.32	2	1-1/2	3-3/16	31/32	13/32	3/4	.343	1.4
50QD21SDS	80.60	4.52								1.5
50QD22SDS	83.20	4.72								1.6
50QD23SDS	87.60	4.92								1.8
50QD24SDS	91.60	5.12								2.0
50QD25SDS	95.60	5.32								2.1
50QD26SDS	103.20	5.52								2.3
50QD27SDS	108.20	5.72								2.4
50QD28SDS	114.80	5.92								2.6
50QD30SDS	120.60	6.32								2.9
50QD32SDS	124.20	6.72								3.2
50QD35SDS	129.40	7.32								3.6
50QD36SDS	131.20	7.52								3.8
50QD40SDS	140.60	8.32								4.7
50QD42SDS	144.20	8.72								5.2
50QD45SDS	148.60	9.31								6.1
50QD48SDS	155.80	9.91	2	1-1/2	3-3/16	31/32	13/32	3/4	.343	8.0
50QD54SK	163.80	11.11	2-5/8	2-1/8	3-7/8	1-17/32	29/32	1-1/4	.343	11.0
50QD60SK	170.40	12.30								12.4
50QD70SK	191.80	14.29								14.3
50QD72SK	202.80	14.69	2-5/8	2-1/8	3-7/8	1-17/32	29/32	1-1/4	.343	15.5
50QD80SF	244.80	16.28	2-15/16	2-1/4	4-5/8	1-21/32	29/32	1-1/4	.343	18.3
50QD84SF	262.60	17.08								20.0
50QD96SF	352.00	19.47								22.3
50QD112SF	412.00	22.65	2-15/16	2-1/4	4-5/8	1-21/32	29/32	1-1/4	.343	30.0

Harden per tooth\$ 1.02

QD Bushing dimensions and prices page 10

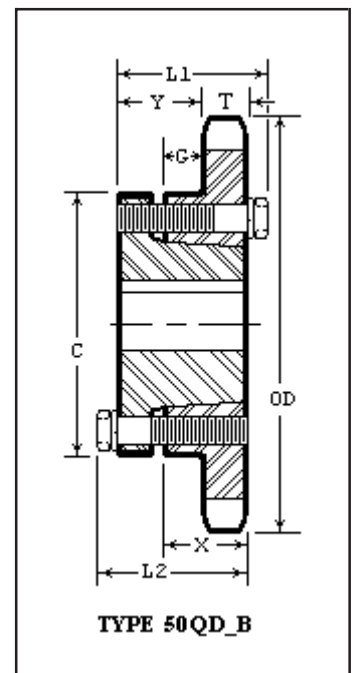

RYLE P/N	LIST PRICE
50QD12HJA	53.40
50QD13HJA	60.60
50QD14HJA	63.20
50QD15HJA	66.20
50QD16HJA	67.20
50QD17HSH	68.60
50QD18HSH	78.00
50QD19HSH	81.80
50QD20HSDS	84.60
50QD21HSDS	98.80
50QD22HSDS	102.40
50QD23HSDS	107.60
50QD24HSDS	112.60
50QD25HSDS	118.00
50QD26HSDS	125.80
50QD27HSDS	132.20
50QD28HSDS	138.80
50QD30HSDS	146.80

Induction
Hardened Teeth :



RYLE Manufacturing Company 1-800-433-0960

No. 50-2 Double Strand 5/8" Pitch

RYLE P/N	LIST PRICE	NO. TEETH	O.D. TEETH	STOCK BORE	MAX BORE	HUB DIA	LTB	LBS.
D50B11H	98.00	11	2.50	5/8	15/16	1-3/4 *	1-7/8	1.0
D50B12H	98.40	12	2.71		1-1/8	1-63/64 *	1-7/8	1.3
D50B13H	101.00	13	2.91		1-5/16	1-7/8	1-3/4	1.6
D50B14H	103.20	14	3.11		1-3/8	2-1/16		1.9
D50B15H	103.20	15	3.32	3/4	1-1/2	2-5/16		2.1
D50B16H	105.80	16	3.52		1-3/4	2-1/2		2.4
D50B17H	108.60	17	3.72		1-7/8	2-11/16		2.9
D50B18H	111.20	18	3.92		1-15/16	2-15/16		3.3
D50B19H	113.00	19	4.12	1	2-1/8	3-1/8		3.7
D50B20H	117.40	20	4.32	1	2-1/4	3-1/4		4.2
D50B21H	123.20	21	4.52	1	2-3/8	3-1/2		4.8
D50B22H	123.20	22	4.72	1	2-3/8	3-9/16	1-7/8	5.3
D50B23H	128.60	23	4.92	1	2-1/2	3-5/8	1-7/8	5.8
D50B24H	135.20	24	5.12	1				6.3
D50B25H	138.00	25	5.32	1				6.7
D50B26	153.20	26	5.52	1		3-3/4		7.2
D50B30	171.40	30	6.32	1	2-1/2	3-3/4	1-7/8	9.6
D50B32	180.60	32	6.72	1				11.0
D50B35	199.80	35	7.32	1				14.0
D50B36	206.40	36	7.52	1	2-3/4	4	2-1/8	14.1
D50B40	212.80	40	8.32	1				16.5
D50B42	236.80	42	8.72	1				17.9
D50B45	255.40	45	9.31	1				20.3
D50B48	291.40	48	9.91	1	2-3/4	4-1/4	2-3/8	24.1
D50B52	324.80	52	10.71	1				27.4
D50B54	367.20	54	11.11	1-1/4				29.2
D50B60	400.40	60	12.30		3	4-1/2	2-3/8	35.9
D50B68	462.80	68	13.89					45.0
D50B72	522.80	72	14.69					50.2
D50B76	547.20	76	15.49					50.8
D50B84	574.00	84	17.08					56.6
D50B95	705.20	95	19.27					65.3
D50B96	720.80	96	19.47					67.4
D50B102	818.80	102	20.66					72.7
D50B112	890.00	112	22.65	1-1/4	3	4-1/2	2-3/8	90.2

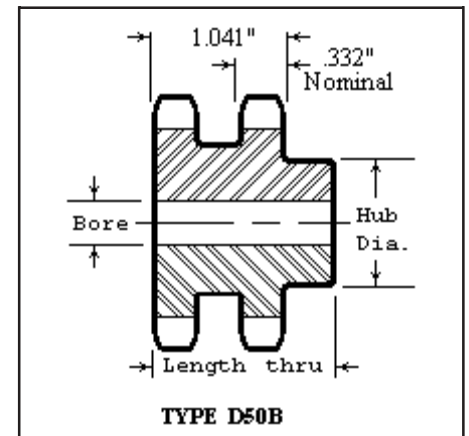

* Indicates hub diameter is grooved for chain clearance. Note: 25 teeth or less already have Hardened Teeth. Maximum bores will accommodate standard keyway and setscrew over key. Slightly larger bores may be possible with shallow keyway and/or setscrew at 90 degrees. Multiple keyways must be priced at factory.

Rebore	\$49.00
Keyway	\$13.40
Setscrew (each)	\$13.40
Harden per tooth	\$ 1.02



RYLE Manufacturing Company 1-800-433-0960

No.50-2 Double No.50-3 Triple 5/8" Pitch

RYLE P/N	LIST PRICE	O.D. TEETH	MAX BORE	TYPE MOUNT	L1 L2	C	DIMENSIONS					LBS.
							Y	X	W	P	T	
D50QD36SK	259.80	7.52	2-5/8	C	2-1/8	3-7/8	5/8	1-1/4	1.041	13/64	.332	12
D50QD45SK	279.40	8.72		C								15
D50QD48SK	329.40	9.91	2-5/8	C	2-1/8	3-7/8	5/8	1-1/4	1.041	13/64	.332	18
D50QD52SF	384.80	10.71	2-15/16	C	2-1/4	4-5/8	3/4	1-1/4	1.041	13/64	.332	20
D50QD54SF	409.40	11.11		C								23
D50QD60SF	476.20	12.30		C								25
D50QD68SF	545.20	13.89		C								31
D50QD72SF	614.00	14.69		C								35
D50QD76SF	645.20	15.49		C								43
D50QD84SF	678.60	17.08		C								57
D50QD95SF	923.40	19.27		C								70
D50QD102SF	963.40	20.66		C								84
D50QD112SF	1074.60	22.65	2-15/16	C	2-1/4	4-5/8	3/4	1-1/4	1.041	13/64	.332	102

Harden per tooth\$ 1.02

QD Bushing dimensions and prices page 10

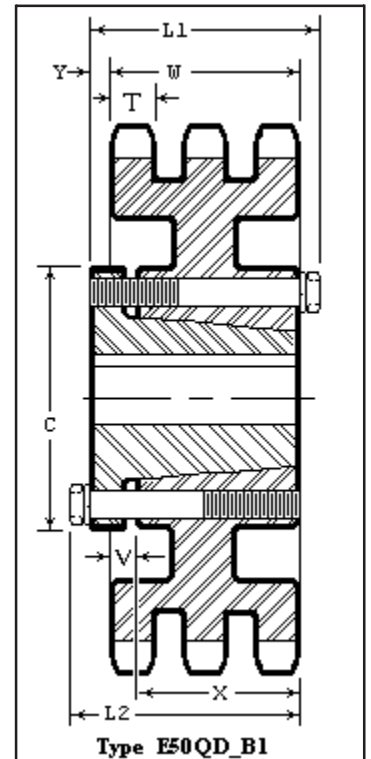
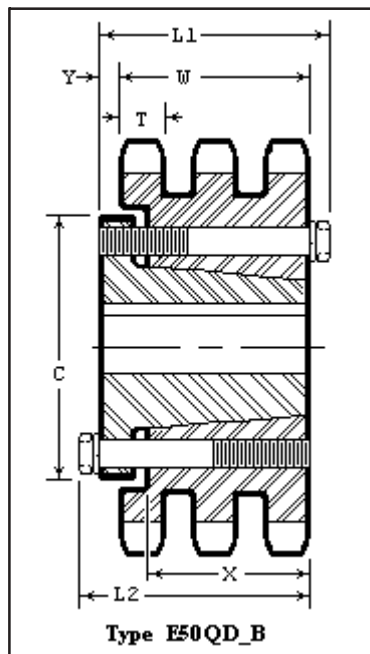
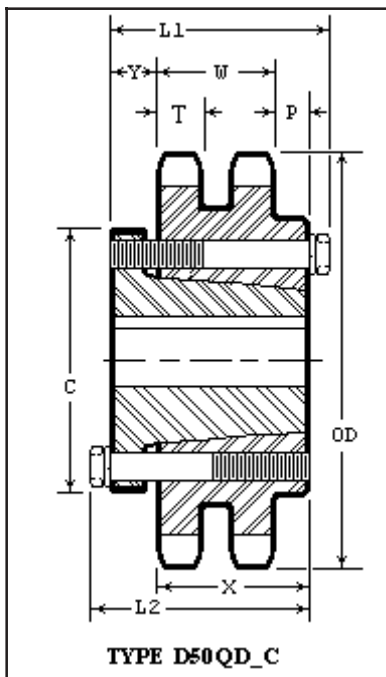

RYLE P/N	LIST PRICE	O.D. TEETH	MAX BORE	TYPE MOUNT	L1 L2	C	DIMENSIONS					LBS.
							Y	X	W	V	T	
E50QD36SK	384.40	7.52	2-5/8	B	2-1/8	3-7/8	1/8	1-1/4	1.751		.332	19
E50QD42SK	429.80	8.72		B								25
E50QD48SK	500.60	9.91	2-5/8	B	2-1/8	3-7/8	1/8	1-1/4	1.751		.332	31
E50QD52SF	578.40	10.71	2-15/16	B	2-1/4	4-5/8	1/4	1-1/4	1.751		.332	37
E50QD60SF	643.00	12.30		B								56
E50QD68SF	701.00	13.89		B								61
E50QD72SF	825.40	14.69		B1						1/2		44
E50QD76SF	950.00	15.49		B1								47
E50QD84SF	996.80	17.08		B1								51
E50QD95SF	1143.60	19.27		B1								59
E50QD102SF	1317.00	20.66	2-15/16	B1	2-1/4	4-5/8	1/4	1-1/4	1.751	1/2	.332	66

Harden per tooth\$ 1.02

QD Bushing dimensions and prices page 10



RYLE Manufacturing Company 1-800-433-0960

No. 50-3 Triple Strand 5/8" Pitch

RYLE P/N	LIST PRICE	NO. TEETH	O.D. TEETH	STOCK BORE	MAX BORE	HUB DIA	LTB	LBS.
E50B11H	130.40	11	2.50	5/8	15/16	1-3/4 *	2-3/4	1.0
E50B12H	131.20	12	2.71		1-1/8	1-63/64 *		1.3
E50B13H	134.00	13	2.91		1-5/16	1-7/8	2-1/2	1.6
E50B14H	134.40	14	3.11		1-3/8	2-1/16		1.9
E50B15H	135.20	15	3.32	3/4	1-1/2	2-5/16		2.1
E50B16H	143.80	16	3.52		1-3/4	2-1/2		2.4
E50B17H	147.80	17	3.72		1-7/8	2-11/16		2.9
E50B18H	154.00	18	3.92		1-15/16	2-15/16		3.3
E50B19H	158.40	19	4.12	1	2-1/8	3-1/8		3.7
E50B20H	165.60	20	4.32	1	2-1/4	3-1/4	2-5/8	4.2
E50B21H	172.60	21	4.52	1	2-3/8	3-1/2		4.8
E50B22H	173.60	22	4.72	1	2-3/8	3-9/16		5.3
E50B23H	176.60	23	4.92	1	2-1/2	3-5/8		5.8
E50B24H	184.60	24	5.12	1				6.3
E50B25H	188.60	25	5.32	1				6.7
E50B26	200.20	26	5.52	1		3-3/4		7.2
E50B30	228.20	30	6.32	1				9.6
E50B35	307.00	35	7.32	1				14.0
E50B36	313.80	36	7.52	1	2-3/4	4	2-3/4	14.1
E50B42	352.40	42	8.72	1				17.9
E50B48	409.40	48	9.91	1	2-3/4	4-1/4	3-1/8	24.1
E50B52	489.40	52	10.71	1				27.4
E50B60	545.20	60	12.30	1-1/4	3	4-1/2		35.9
E50B68	596.20	68	13.89					45.0
E50C72 †	700.80	72	14.69					50.2
E50C76 †	809.80	76	15.49					50.8
E50C84 †	847.60	84	17.08					56.6
E50C95 †	974.40	95	19.27				3-3/4	65.3
E50C102 †	1121.40	102	20.66					72.7

* Indicates hub diameter is grooved for chain clearance. Note: 25 teeth or less already have Hardened Teeth. Maximum bores will accommodate standard keyway and setscrew over key. Slightly larger bores may be possible with shallow keyway and/or setscrew at 90 degrees. Multiple keyways must be priced at factory.

† Indicates spoke wheel design

Rebore	\$49.00
Keyway	\$13.40
Setscrew (each)	\$13.40
Harden per tooth	\$ 1.02

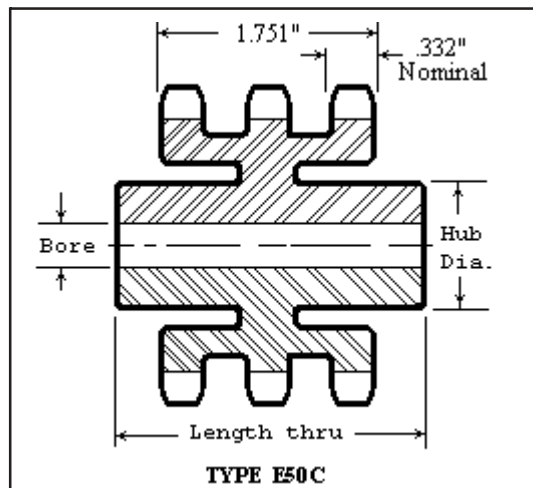
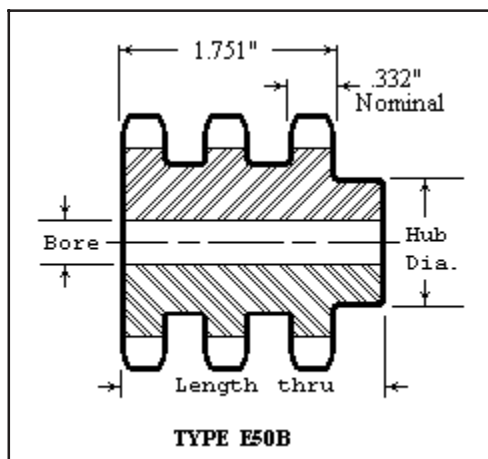



RYLE Manufacturing Company 1-800-433-0960

No. 50-4 Quadruple Strand 5/8" Pitch

RYLE P/N	LIST PRICE	NO. TEETH	O.D. TEETH	STOCK BORE	MAX BORE	HUB DIA	LTB	LBS.
F50B13H	232.20	13	2.91	5/8	1-5/16	1-7/8	3-1/4	2.9
F50B14H	242.80	14	3.11	3/4	1-3/8	2-1/16		3.4
F50B15H	253.20	15	3.32	1	1-1/2	2-5/16		3.9
F50B16H	275.40	16	3.52	1	1-3/4	2-1/2		4.6
F50B17H	296.80	17	3.72	1	1-7/8	2-11/16		5.4
F50B18H	319.80	18	3.92	1	1-15/16	2-15/16		6.8
F50B19H	340.00	19	4.12	1	2-1/8	3-1/8	3-1/4	7.3
F50B20H	366.40	20	4.32	1	2-1/4	3-1/4	3-1/2	8.3
F50B21H	398.40	21	4.52	1	2-3/8	3-1/2		9.3
F50B22H	425.40	22	4.72	1	2-1/2	3-11/16		10.0
F50B23H	464.80	23	4.92	1	2-11/16	3-15/16		11.0
F50B24H	474.60	24	5.12	1	2-3/4	4-1/8		12.0
F50B25H	502.00	25	5.32	1	2-7/8	4-15/16		15.0
F50B26H	554.00	26	5.52	1	3	4-1/2		17.0
F50B28	554.00	28	5.92	1			3-3/4	18.0
F50B30	578.00	30	6.32	1				20.0
F50B35	656.00	35	7.32	1-1/4				26.0
F50B36	682.00	36	7.52					28.0
F50B40	780.00	40	8.32					36.0
F50B45	870.00	45	9.31					45.0
F50B48	1040.00	48	9.91					50.0
F50B52	1176.00	52	10.71					55.0
F50B60	1462.00	60	12.30		3-1/4	5		77.0
F50B68	1974.00	68	13.89					98.0
F50B72	2176.00	72	14.69					111.0
F50B84	2828.00	84	17.08					132.0

Note: 25 teeth or less already have Hardened Teeth.

Maximum bores will accommodate standard keyway and setscrew over key. Slightly larger bores may be possible with shallow keyway and/or setscrew at 90 degrees.

Multiple keyways must be priced at factory.

Rebore	\$49.00
Keyway	\$13.40
Setscrew (each)	\$13.40
Harden per tooth	\$ 1.02

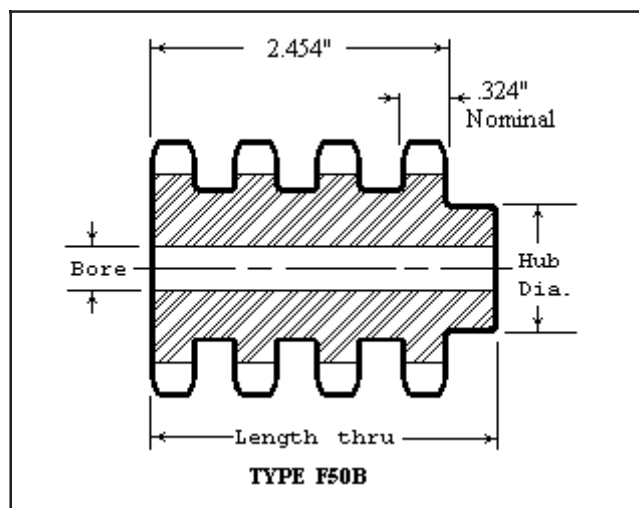



RYLE Manufacturing Company 1-800-433-0960

No. 60 3/4" Pitch

Type B

Type A

RYLE P/N	LIST PRICE	NO. TEETH	O.D. TEETH	STOCK BORE	MAX BORE	HUB DIA	LTB	LBS.	RYLE P/N	LIST PRICE	LBS
60B8	27.20	8	2.26	5/8	13/16	1-15/32 *	1-1/4	.6	60A9	30.00	.5
60B9	27.60	9	2.51	3/4	7/8	1-11/16 *		.8	60A10	31.20	.6
60B10	29.80	10	2.76		1-1/8	1-15/16 *		1.0	60A11	32.40	.8
60B11	31.60	11	3.00		1-5/16	2-1/16 *		1.3	60A12	33.00	.9
60B12	33.80	12	3.25		1-3/8	2-3/8 *		1.5	60A13	33.80	1.0
60B13	36.80	13	3.49		1-1/2	2-11/32		1.8	60A14	35.20	1.2
60B14	39.60	14	3.74		1-3/4	2-9/16		2.0	60A15	36.60	1.3
60B15	45.80	15	3.98		1-7/8	2-7/8		2.4	60A16	37.80	1.5
60B16	51.60	16	4.22		2	3-1/16		2.8	60A17	39.20	1.7
60B17	54.20	17	4.46		2-1/4	3-1/4		3.3	60A18	40.40	1.9
60B18	57.80	18	4.70		2-3/8	3-1/2		3.8	60A19	41.80	2.1
60B19	65.80	19	4.85					4.0	60A20	43.20	2.4
60B20	70.40	20	5.19		2-5/8	3-7/8		4.6	60A21	44.40	2.5
60B21	72.60	21	5.43		2-3/4	4		5.0	60A22	45.80	2.7
60B22	78.20	22	5.67					5.3	60A23	47.20	3.0
60B23	80.60	23	5.91					5.7	60A24	49.80	3.2
60B24	87.20	24	6.15					5.9	60A25	49.80	3.3
60B25	93.80	25	6.39					6.1	60A26	51.20	3.5
60B26	97.00	26	6.63					6.3	60A27	53.00	3.8
60B27	102.40	27	6.87					6.5	60A28	53.80	4.0
60B28	103.20	28	7.11					6.7	60A29	57.00	4.4
60B29	106.40	29	7.35					6.8	60A30	57.80	4.7
60B30	107.20	30	7.59				1-1/2	7.0	60A31	61.00	5.0
60B31	110.00	31	7.83					8.0	60A32	61.80	5.3
60B32	110.40	32	8.07					8.3	60A33	66.20	5.5
60B33	112.60	33	8.30					8.5	60A34	67.20	5.9
60B34	113.00	34	8.54	1				8.8	60A35	67.60	6.3
60B35	113.80	35	8.78	1				9.0	60A36	69.80	6.7
60B36	118.40	36	9.02	1				9.3	60A37	74.40	7.1
60B37	129.00	37	9.26	1				9.5	60A38	75.20	7.5
60B38	130.00	38	9.50	1	2-3/4	4-1/4		10.2	60A39	75.60	7.9
60B39	130.40	39	9.74	1				11.0	60A40	76.60	8.3
60B40	131.20	40	9.98	1				11.7	60A41	79.60	8.8
60B41	144.60	41	10.22	1				12.5	60A42	80.60	9.2
60B42	145.00	42	10.46	1				13.2	60A43	83.20	9.5
60B43	147.00	43	10.70	1				13.7	60A44	85.80	9.8
60B44	149.00	44	10.94	1				14.0	60A45	87.20	10.6
60B45	150.00	45	11.18	1				14.5	60A46	89.80	11.0
60B46	155.20	46	11.42	1				14.8	60A47	92.60	11.1
60B47	159.80	47	11.65	1				15.5	60A48	93.80	11.5
60B48	160.60	48	11.89	1				16.0	60A49	103.20	12.0
60B49	170.20	49	12.13	1				16.5	60A50	112.60	12.5
60B50	179.80	50	12.37	1				17.0	60A51	112.60	13.0
60B51	180.40	51	12.61	1				17.5	60A52	113.00	13.6
60B52	181.00	52	12.85	1				18.0	60A53	113.00	14.1
60B53	181.60	53	13.09	1				18.7	60A54	113.80	14.7
60B54	182.40	54	13.33	1			1-3/4	22.0	60A55	124.60	15.3
60B55	199.80	55	13.57	1				22.5	60A56	138.40	15.9
60B56	207.40	56	13.81	1				23.0	60A57	138.40	16.5
60B57	208.00	57	14.04	1				23.5	60A58	139.40	17.1
60B58	208.80	58	14.28	1				24.0	60A59	139.60	17.6
60B59	209.60	59	14.52	1				24.5	60A60	140.60	18.0
60B60	210.40	60	14.76	1-1/4				25.0	60A62	161.40	19.0
		62	15.23						60A64	182.00	20.7
60B64	266.20	64	15.72					27.0	60A65	183.80	21.4
60B65	267.40	65	15.86					29.0	60A66	184.60	21.8
60B66	268.60	66	16.19					29.5	60A68	202.40	23.5
60B68	276.80	68	16.67					30.4	60A70	204.60	24.0
60B70	283.40	70	17.15					33.0	60A72	215.80	26.0
60B72	299.00	72	17.63				2	35.0	60A76	255.80	30.6
60B76	340.80	76	18.58					39.0	60A80	262.60	35.5
60B80	354.20	80	19.54					43.0	60A84	302.60	39.6
60B84	380.80	84	20.47		3-3/4	5-1/2	2-1/4	47.0	60A90	373.80	43.4
60B90	454.80	90	21.93					52.5	60A96	387.20	51.2
60B96	468.00	96	23.36					60.0	60A112	478.40	68.5
60B112	598.00	112	27.18	1-1/2				78.0	60A120	628.00	78.0
		120	29.09								

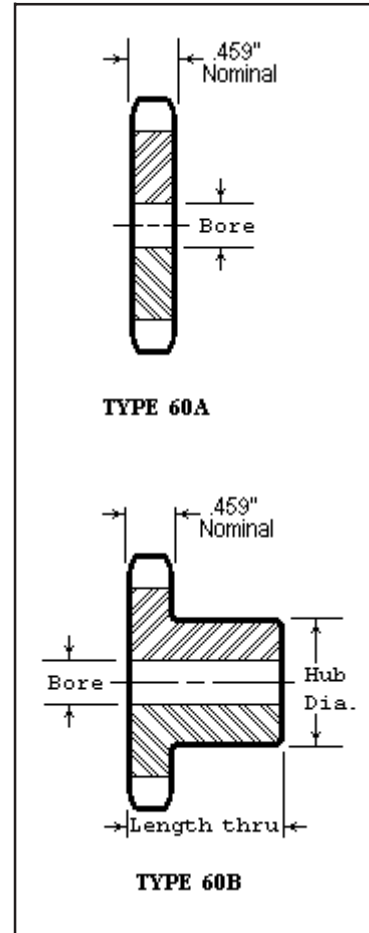

* Indicates hub diameter is grooved for chain clearance. Maximum bores will accommodate standard keyway and setscrew over key.

Slightly larger bores may be possible with shallow keyway and/or setscrew at 90 degrees.
Multiple keyways must be priced at factory.

Split Type A plate.....\$ 3.42 per inch of sprocket diameter

Rebore	\$49.00
Keyway	\$13.40
Setscrew (each)	\$13.40
Harden per tooth	\$ 1.56

Drill Type A plate (4) holes = \$28.00
(6) holes = \$42.00
(8) holes = \$56.00



RYLE Manufacturing Company 1-800-433-0960

No. 60 3/4" Pitch Stainless Steel

Type B

Type A

RYLE P/N	LIST PRICE	NO. TEETH	O.D. TEETH	STOCK BORE	MAX BORE	HUB DIA	LTB	LBS	RYLE P/N	LIST PRICE	LBS
60B10SS	166.00	10	2.76	3/4	1-1/8	1-15/16 *	1-1/4	1.0			
60B11SS	186.80	11	3.00		1-5/16	2-1/16 *		1.3			
60B12SS	213.20	12	3.25		1-3/8	2-3/8 *		1.5			
60B13SS	234.00	13	3.49		1-1/2	2-11/32		1.8			
60B14SS	255.40	14	3.74		1-3/4	2-9/16		2.0			
60B15SS	310.20	15	3.98		1-7/8	2-7/8		2.4			
60B16SS	336.00	16	4.22		2	3-1/16		2.8			
60B17SS	371.60	17	4.46		2-1/4	3-1/4		3.3			
60B18SS	404.80	18	4.70		2-3/8	3-1/2		3.8			
60B19SS	440.60	19	4.85					4.0	60A19SS	317.60	2.1
60B20SS	474.40	20	5.19		2-5/8	3-7/8		4.6			
60B21SS	498.40	21	5.43		2-3/4	4		5.0	60A21SS	398.20	2.5
60B22SS	554.00	22	5.67					5.3	60A22SS	442.80	2.7
60B23SS	614.00	23	5.91					5.7	60A23SS	491.80	3.0
60B24SS	680.80	24	6.15					5.9	60A24SS	545.20	3.2
60B25SS	766.20	25	6.39					6.1	60A25SS	574.60	3.3
60B26SS	803.20	26	6.63					6.3	60A26SS	643.00	3.5
60B28SS	843.20	28	7.11					6.7	60A28SS	645.20	4.0
60B30SS	875.60	30	7.59				1-1/2	7.0	60A30SS	656.80	4.7
60B35SS	948.60	35	8.78	1				9.0	60A35SS	711.40	6.3
60B40SS	1070.20	40	9.98	1				11.7	60A40SS	801.00	8.3
60B45SS	1240.00	45	11.18	1				14.5	60A45SS	930.00	10.6
60B60SS	1763.00	60	14.76	1-1/4				25.0	60A60SS	1321.60	18.0

* Indicates hub diameter is grooved for chain clearance.

Maximum bores will accommodate standard keyway and setscrew over key. Slightly larger bores may be possible with shallow keyway and/or setscrew at 90 degrees. Multiple keyways must be priced at factory.

Split Type A plate	\$ 3.42 per inch of sprocket diameter
Rebore	\$49.00
Keyway	\$13.40
Setscrew (each)	\$13.40
Drill Type A plate	(4) holes = \$28.00
	(6) holes = \$42.00
	(8) holes = \$56.00

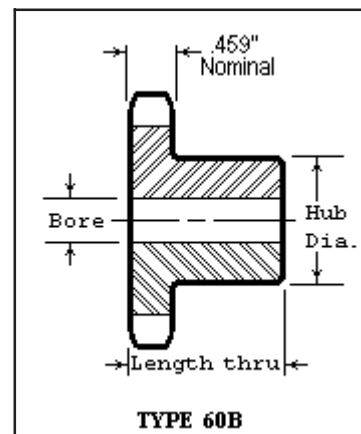
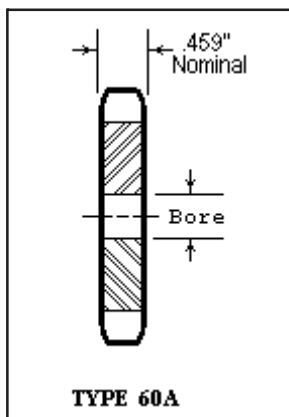



RYLE Manufacturing Company 1-800-433-0960

No. 60 3/4" Pitch

RYLE P/N	LIST PRICE	TYPE MOUNT	O.D. TEETH	MAX BORE	L1	L2	C	Y	G	X	T	LBS
60QD11JA	54.20	B	3.00	1-1/4	1-1/8	1-1/8	2-1/16	35/64	11/64	5/8	.459	.7
60QD12JA	57.40	B	3.25									.7
60QD13JA	59.20	B	3.49	1-1/4	1-1/8	1-1/8	2-1/16	35/64	11/64	5/8	.459	.8
60QD14SH	62.40	B	3.74	1-5/8	1-7/16	1-7/16	2-11/16	51/64	23/64	13/16	.459	.8
60QD15SH	66.20	B	3.98									.9
60QD16SH	77.40	B	4.22	1-5/8	1-7/16	1-7/16	2-11/16	51/64	23/64	13/16	.459	1.1
60QD17SDS	80.00	B	4.46	2	1-1/2	1-1/2	3-3/16	55/64	19/64	3/4	.459	1.3
60QD18SDS	88.60	B	4.70									1.5
60QD19SDS	93.00	B	4.95									1.6
60QD20SDS	95.60	B	5.19									1.7
60QD21SDS	98.40	B	5.43									2.0
60QD22SDS	105.40	B	5.67									2.2
60QD23SDS	109.40	B	5.91									2.5
60QD24SDS	117.00	B	6.15									2.8
60QD25SDS	122.80	B	6.39	2	1-1/2	1-1/2	3-3/16	55/64	19/64	3/4	.459	3.0
60QD26SK	125.80	B	6.63	2-5/8	2-1/8	2-1/8	3-7/8	1-27/64	51/64	1-1/4	.459	4.6
60QD27SK	126.80	B	6.87									5.0
60QD28SK	128.00	B	7.11									5.3
60QD30SK	129.00	B	7.59									6.0
60QD32SK	143.20	B	8.01									6.8
60QD35SK	145.60	B	8.78									7.6
60QD36SK	148.20	B	9.02									8.0
60QD40SK	151.80	B	9.02	2-5/8	2-1/8	2-1/8	3-7/8	1-27/64	51/64	1-1/4	.459	9.6
60QD42SF	158.40	B	9.98	2-15/16	2-1/4	2-1/4	4-5/8	1-35/64	51/64	1-1/4	.459	10.6
60QD45SF	160.20	B	10.46									12.3
60QD48SF	192.00	B	11.89									13.5
60QD54SF	196.60	B	13.33									17.4
60QD60SF	256.80	B	14.76									20.1
60QD70SF	290.00	B	17.15									23.6
60QD72SF	307.00	B	17.63									24.5
60QD80SF	373.80	B	19.54									43.0
60QD84SF	400.40	B	20.49									50.4
60QD96SF	610.40	B	23.36	2-15/16	2-1/4	2-1/4	4-5/8	1-35/64	51/64	1-1/4	.459	65.1
60QD112E	625.60	B1	27.18	3-1/2	2-5/8	2-15/16	6	2-3/16	1-11/64	1-5/8	.459	74.7

Harden per tooth\$ 1.56

QD Bushing dimensions and prices page 10

RYLE P/N	LIST PRICE
60QD11HJA	69.00
60QD12HJA	73.00
60QD13HJA	76.60
60QD14HSH	81.40
60QD15HSH	86.80
60QD16HSH	98.80
60QD17HSDS	102.40
60QD18HSDS	113.00
60QD19HSDS	118.40
60QD20HSDS	122.40
60QD21HSDS	126.40
60QD22HSDS	135.20
60QD23HSDS	140.20
60QD24HSDS	149.60
60QD25HSDS	156.20
60QD26HSK	158.00
60QD27HSK	160.20
60QD28HSK	163.40
60QD30HSK	166.00

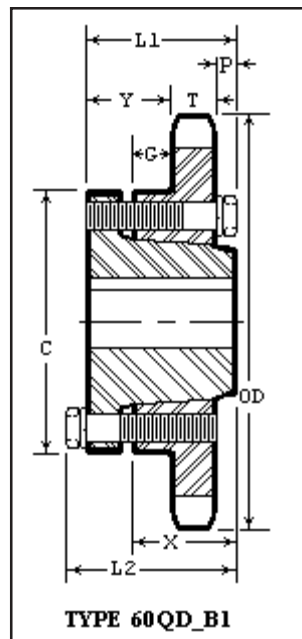
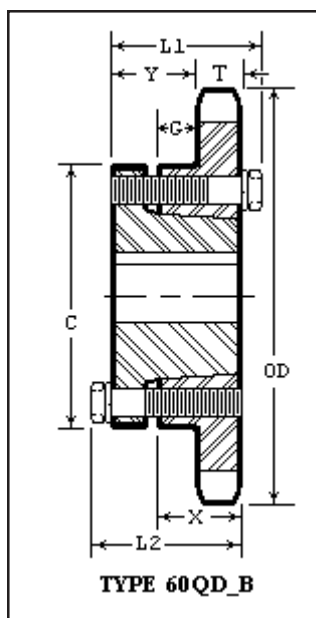



RYLE Manufacturing Company 1-800-433-0960

No. 60 3/4" Pitch Bored to Size & Winch

RYLE P/N	LIST PRICE	NO. TEETH	O.D. TEETH	LBS	AVAILABLE BORE SIZES WITH STANDARD KEYWAY AND (2) SETSCREWS													
60BS9	31.60	9	2.51	.8	3/4	7/8	1											
60BS10	33.00	10	2.76	1.0	3/4	7/8	1											
60BS11	35.60	11	3.00	1.3	3/4	7/8	1	1-1/8	1-3/16	1-1/4 *								
60B11W	35.60	11W	3.00	1.3						1-1/4 *								
60BS12	39.60	12	3.25	1.5	3/4	7/8	1	1-1/8	1-3/16	1-1/4 *		1-7/16 *						
60B12W	39.60	12W	3.25	1.5						1-1/4 *								
60BS13	44.40	13	3.49	1.8	3/4	7/8	1	1-1/8	1-3/16	1-1/4	1-3/8 *	1-7/16 *	1-1/2 *					
60BS14	52.00	14	3.74	2.0	3/4	7/8	1	1-1/8	1-3/16	1-1/4	1-3/8	1-7/16 *	1-1/2 *					
60BS15	60.00	15	3.98	2.4	3/4	7/8	1	1-1/8	1-3/16	1-1/4	1-3/8	1-7/16	1-1/2	1-5/8	1-3/4 *			
60B15W	60.00	15W	3.98	2.4						1-1/4								
60BS16	66.80	16	4.22	2.8	3/4	7/8	1	1-1/8	1-3/16	1-1/4	1-3/8	1-7/16	1-1/2	1-5/8	1-3/4	1-15/16 *		
60BS17	73.80	17	4.46	3.3			1	1-1/8	1-3/16	1-1/4	1-3/8	1-7/16	1-1/2	1-5/8	1-3/4	1-15/16 *		
60BS18	81.40	18	4.70	3.8			1	1-1/8	1-3/16	1-1/4	1-3/8	1-7/16	1-1/2	1-5/8	1-3/4	1-15/16		
60B18W	81.40	18W	4.70	3.8						1-1/4								
60BS19	85.00	19	4.85	4.0	1	1-1/8	1-3/16	1-1/4	1-3/8	1-7/16	1-1/2	1-5/8	1-3/4	1-15/16				
60BS20	89.00	20	5.19	4.6	1	1-1/8	1-3/16	1-1/4	1-3/8	1-7/16	1-1/2	1-5/8	1-3/4	1-15/16				
60B20W	89.00	20W	5.19	4.6				1-1/4										
60BS21	101.40	21	5.43	5.0	1	1-1/8	1-3/16	1-1/4	1-3/8	1-7/16	1-1/2	1-5/8	1-3/4	1-15/16				
60BS22	108.60	22	5.67	5.3	1	1-1/8	1-3/16	1-1/4	1-3/8	1-7/16	1-1/2	1-5/8	1-3/4	1-15/16				
60BS23	111.20	23	5.91	5.7	1	1-1/8	1-3/16	1-1/4	1-3/8	1-7/16	1-1/2	1-5/8	1-3/4	1-15/16				
60BS24	118.80	24	6.15	5.9	1	1-1/8	1-3/16	1-1/4	1-3/8	1-7/16	1-1/2	1-5/8	1-3/4	1-15/16				
60B24W	118.80	24W	6.15	5.9				1-1/4										
60BS25	126.40	25	6.39	6.1	1	1-1/8	1-3/16	1-1/4	1-3/8	1-7/16	1-1/2	1-5/8	1-3/4	1-15/16				
60BS26	128.60	26	6.63	6.3	1	1-1/8	1-3/16	1-1/4	1-3/8	1-7/16	1-1/2	1-5/8	1-3/4	1-15/16				
60BS27	131.00	27	6.87	6.4	1	1-1/8	1-3/16	1-1/4	1-3/8	1-7/16	1-1/2	1-5/8	1-3/4	1-15/16				
60BS28	137.00	28	7.11	6.7	1	1-1/8	1-3/16	1-1/4	1-3/8	1-7/16	1-1/2	1-5/8	1-3/4	1-15/16				
60BS29	139.60	29	7.35	6.8	1	1-1/8	1-3/16	1-1/4	1-3/8	1-7/16	1-1/2	1-5/8	1-3/4	1-15/16				
60BS30	142.00	30	7.59	7.0	1	1-1/8	1-3/16	1-1/4	1-3/8	1-7/16	1-1/2	1-5/8	1-3/4	1-15/16				
60BS32	144.60	32	8.07	8.2	1	1-1/8	1-3/16	1-1/4	1-3/8	1-7/16	1-1/2	1-5/8	1-3/4	1-15/16				
60BS35	149.60	35	8.78	9.0	1	1-1/8	1-3/16	1-1/4	1-3/8	1-7/16	1-1/2	1-5/8	1-3/4	1-15/16				
60BS36	153.40	36	9.02	9.3	1	1-1/8	1-3/16	1-1/4	1-3/8	1-7/16	1-1/2	1-5/8	1-3/4	1-15/16	2	2-3/16	2-7/16	
60BS40	168.60	40	9.98	11.7	1	1-1/8	1-3/16	1-1/4	1-3/8	1-7/16	1-1/2	1-5/8	1-3/4	1-15/16	2	2-3/16	2-7/16	
60BS42		42	10.46	12.4	1	1-1/8	1-3/16	1-1/4	1-3/8	1-7/16	1-1/2	1-5/8	1-3/4	1-15/16	2	2-3/16	2-7/16	
60BS45	190.40	45	11.18	14.5	1	1-1/8	1-3/16	1-1/4	1-3/8	1-7/16	1-1/2	1-5/8	1-3/4	1-15/16	2	2-3/16	2-7/16	
60BS48	205.20	48	11.89	15.4	1	1-1/8	1-3/16	1-1/4	1-3/8	1-7/16	1-1/2	1-5/8	1-3/4	1-15/16	2	2-3/16	2-7/16	
60BS54	215.60	54	13.33	21.0	1	1-1/8	1-3/16	1-1/4	1-3/8	1-7/16	1-1/2	1-5/8	1-3/4	1-15/16	2	2-3/16	2-7/16	
60BS60	226.00	60	14.76	25.0				1-1/4	1-3/8	1-7/16	1-1/2	1-5/8	1-3/4	1-15/16	2	2-3/16	2-7/16	
60BS70	336.40	70	17.15	31.4				1-1/4	1-3/8	1-7/16	1-1/2	1-5/8	1-3/4	1-15/16	2	2-3/16	2-7/16	
60BS72		72	17.63	33.5				1-1/4	1-3/8	1-7/16	1-1/2	1-5/8	1-3/4	1-15/16	2	2-3/16	2-7/16	
60BS80	409.20	80	19.54	41.2				1-1/4	1-3/8	1-7/16	1-1/2	1-5/8	1-3/4	1-15/16	2	2-3/16	2-7/16	

* Indicates setscrew is at 90 degrees to keyway only. Hub diameters may vary to suit bore sizes. W=Winch sprocket with non-standard 5/16 x 5/32" keyway

RYLE P/N	LIST PRICE
60BS9H	45.60
60BS10H	48.60
60BS11H	52.80
60BS12H	58.40
60BS13H	64.80
60BS14H	74.00
60BS15H	83.60
60BS16H	91.80
60BS17H	100.40
60BS18H	109.60
60BS19H	114.60
60BS20H	120.20

**Induction
Hardened
Teeth**

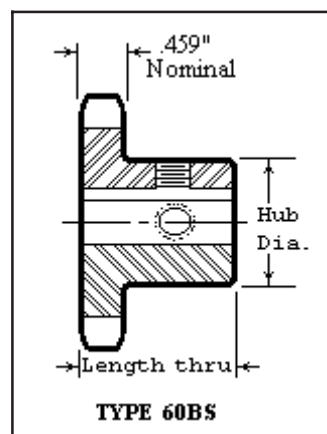

TYPE 60BS



RYLE Manufacturing Company 1-800-433-0960

No. 60 3/4" Pitch

Type C

RYLE P/N	LIST PRICE	NO. TEETH	O.D. TEETH	STOCK BORE	MAX BORE	HUB DIA	LTB	LBS
60C12	126.00	12	3.24	3/4	1-3/8	2-1/8	2	2.3
60C13	130.00	13	3.49		1-1/2	2-3/8		2.8
60C14	135.20	14	3.73		1-3/4	2-9/16		3.2
60C15	142.40	15	3.97		1-7/8	2-13/16		3.4
60C16	155.90	16	4.22		2	3-1/16		4.2
60C17	160.80	17	4.46		2-1/4	3-3/8		4.8
60C18	174.00	18	4.70	3/4	2-3/8	3-9/16	2	5.6

Rebore	\$49.00
Keyway	\$13.40
Setscrew (each)	\$13.40
Harden per tooth	\$ 1.56

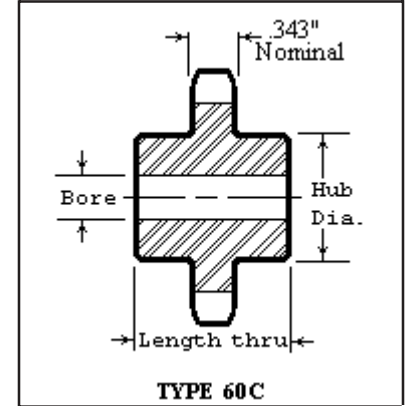

RYLE P/N	LIST PRICE	NO. TEETH	O.D. TEETH	W	B	L	LBS
60BB13H	65.40	13	3.49	0.459	5/8	.720	.78
60BB15H	70.00	15	3.98	0.459	5/8	.720	1.0

BB = Sealed Ball Bearing

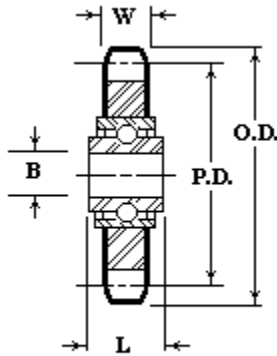

Type B Hard Teeth

RYLE P/N	LIST PRICE
60B9H	41.60
60B10H	45.40
60B11H	48.80
60B12H	52.60
60B13H	57.20
60B14H	61.60
60B15H	69.20
60B16H	76.60
60B17H	80.80
60B18H	86.00
60B19H	95.60
60B20H	101.60

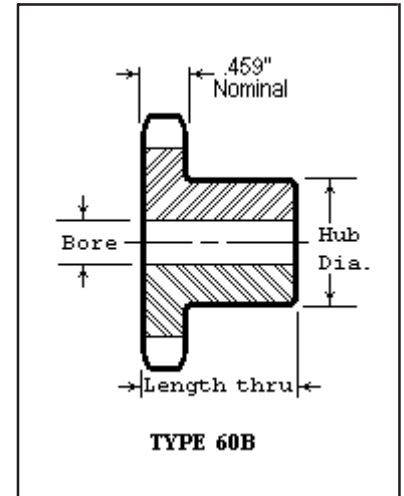

Induction Hardened Teeth

Double-Single

RYLE P/N	LIST PRICE	TEETH O.D.	STOCK BORE	MAX BORE	LTB	HUB DIA	LBS
DS60A13	124.60	3.49	3/4	1-1/4	1-61/64	2-11/32	2.6
DS60A14	133.40	3.74		1-5/16		2-9/16	3.2
DS60A15	144.60	3.98		1-1/2		2-7/8	3.8
DS60A16	155.80	4.22		1-11/16		3-3/64	4.5
DS60A17	164.60	4.46		1-3/4		3-1/4	5.3
DS60A18	175.80	4.70		1-7/8		3-15/32	6.5
DS60A19	206.80	4.95		2-1/16		3-45/64	6.8
DS60A20	215.80	5.19		2-1/4		3-61/64	7.0
DS60A21	220.20	5.43	3/4	2-3/4	1-61/64	4-3/16	7.5

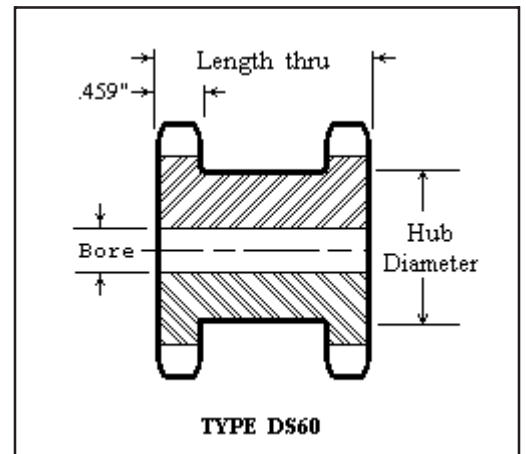



RYLE Manufacturing Company 1-800-433-0960

No. 60-2 Double Strand 3/4" Pitch

RYLE P/N	LIST PRICE	NO. TEETH	O.D. TEETH	STOCK BORE	MAX BORE	HUB DIA	LTB	LBS.
D60B11H	91.60	11	3.00	3/4	1-1/4	2-1/16 *	2-3/8	1.7
D60B12H	95.20	12	3.25		1-7/16	2-3/8 *		2.2
D60B13H	103.20	13	3.49		1-1/2	2-1/4	2-1/8	2.6
D60B14H	108.60	14	3.74		1-3/4	2-1/2		3.2
D60B15H	113.00	15	3.98		1-7/8	2-13/16		3.8
D60B16H	121.00	16	4.22		2	3		4.5
D60B17H	126.40	17	4.46		2-1/4	3-1/4		5.3
D60B18H	133.00	18	4.70		2-3/8	3-1/2		5.9
D60B19H	140.60	19	4.95		2-1/2	3-11/16		6.5
D60B20H	150.40	20	5.19		2-1/2	3-3/4		7.3
D60B21H	159.80	21	5.43	1	2-3/4	4-1/8		8.1
D60B22H	162.00	22	5.67	1		4-1/4		9.2
D60B23H	163.40	23	5.91	1				10.1
D60B24H	166.00	24	6.15	1				11.0
D60B25H	172.60	25	6.39	1				11.7
D60B26	179.40	26	6.63	1				12.6
D60B30	255.00	30	7.59	1			2-3/8	16.0
D60B32	267.40	32	8.07	1-1/4	3	4-1/2		20.0
D60B35	284.80	35	8.78					26.0
D60B36	292.80	36	9.02					26.9
D60B40	349.40	40	9.98		3-1/4	4-3/4	2-3/4	30.8
D60B42	376.00	42	10.46					33.1
D60B45	445.00	45	11.18					37.1
D60B52	511.80	52	12.85					48.7
D60B60	627.40	60	14.76					70.0
D60C68	747.60	68	16.67		3-5/16	5	3	80.0
D60C72	756.40	72	17.63					85.0
D60C76	814.20	76	18.58	1-1/2				89.2
D60C95	1230.40	95	23.12		3-3/4	5-1/2	3-1/2	111.5

* Indicates hub diameter is grooved for chain clearance.

Note: 25 teeth or less already have Hardened Teeth.

Maximum bores will accommodate standard keyway and setscrew over key. Slightly larger bores may be possible with shallow keyway and/or setscrew at 90 degrees. Multiple keyways must be priced at factory.

Rebore	\$49.00
Keyway	\$13.40
Setscrew (each)	\$13.40
Harden per tooth	\$ 1.56

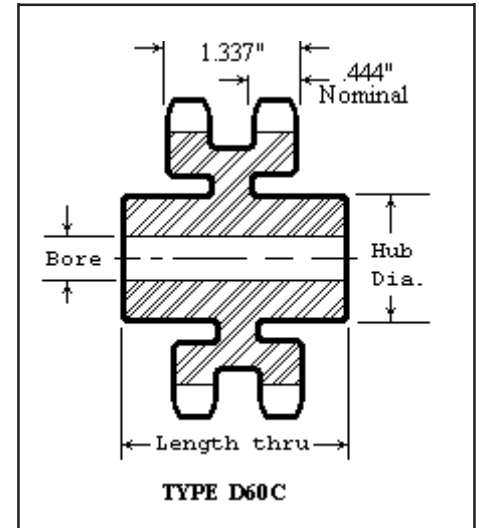
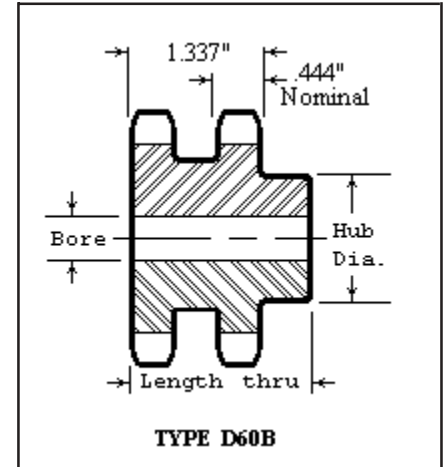



RYLE Manufacturing Company 1-800-433-0960

No. 60-2 Double Strand 3/4" Pitch

RYLE P/N	LIST PRICE	O.D. TEETH	MAX BORE	TYPE MOUNT	L1	DIMENSIONS							LBS.
						L2	C	Y	X	W	T	P	
D60QD14HSH	179.40	3.74	1-1/4	B	2-1/8	2-9/32	2-11/16	9/16	1-1/4	1.341	.444	7/32	1.5
D60QD22HSDS	241.60	5.67	2	C1	1-17/32	1-15/32	3-3/16	9/16	3/4				4.4
D60QD36SF	347.60	9.02	2-15/16	C1	2	2-1/4	4-5/8	3/4	1-1/4			5/16	17.0
D60QD42E	380.40	10.46	3-1/2	C2	2-5/8	2-15/16	6	7/8	1-5/8			13/32	27.0
D60QD45E	460.60	11.18		C2									32.0
D60QD52E	536.20	12.85		C2									45.0
D60QD60E	671.80	14.76		C2									40.0
D60QD68E	796.60	16.67		C4									38.0
D60QD76E	890.00	18.58		C4									45.0
D60QD95E	1370.40	23.12	3-1/2	C4	2-5/8	2-15/16	6	7/8	1-5/8	1.341	.444	13/32	80.0

Harden per tooth\$ 1.56

QD Bushing dimensions and prices page 10

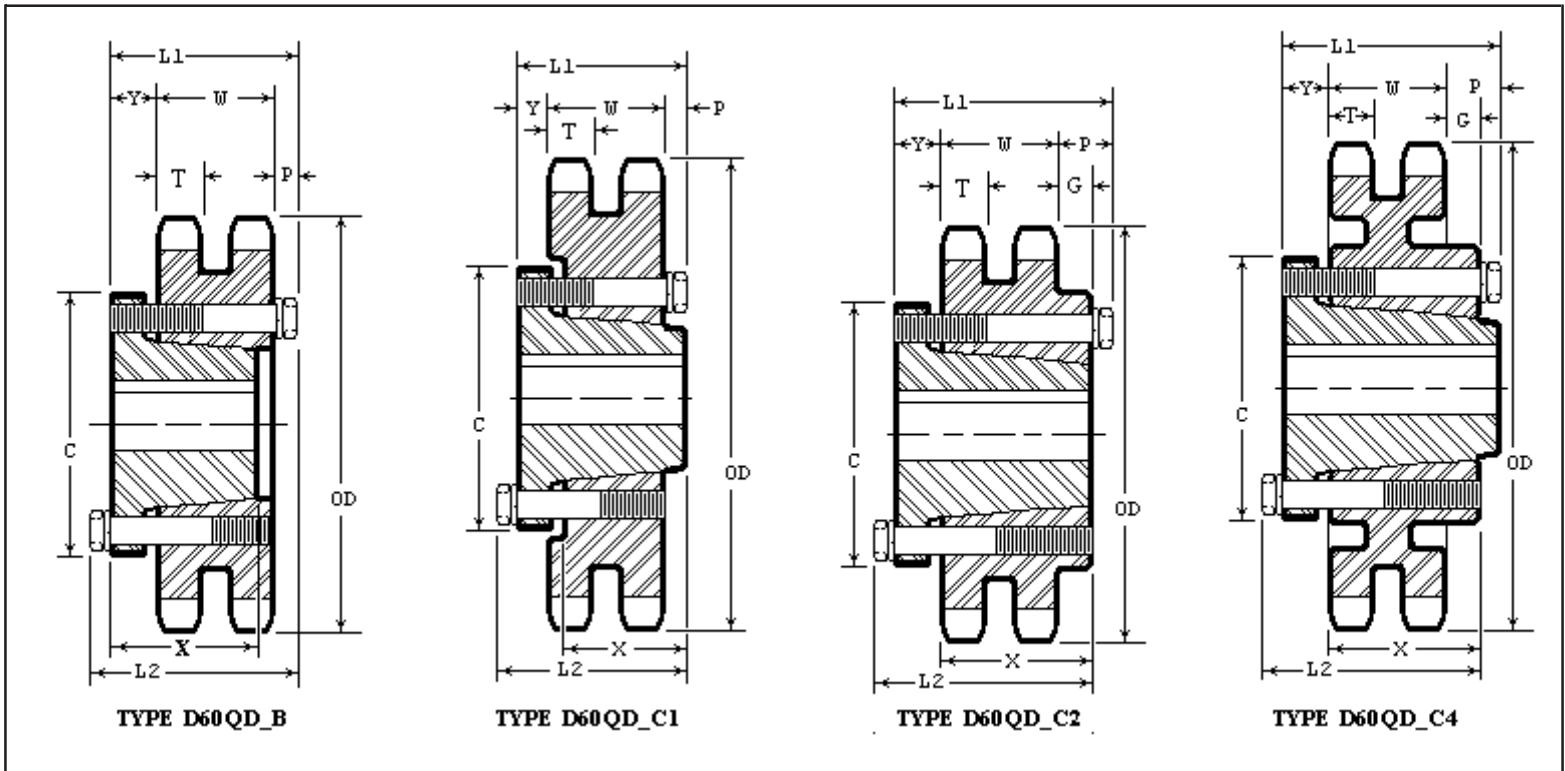



RYLE Manufacturing Company 1-800-433-0960

No. 60-3 Triple 3/4" Pitch

RYLE P/N	LIST PRICE	O.D. TEETH	MAX BORE	TYPE MOUNT	DIMENSIONS									LBS.	
					L1	L2	C	Y	P	G	V	X	T		W
E60QD36E	462.80	9.02	3-1/2	B2	2-5/8	2-15/16	6	17/64	1/8			1-5/8	.444	2.230	37
E60QD42E	607.40	10.46		B2											50
E60QD52E	849.80	12.85		B2	2-5/8	2-15/16	6	17/64	1/8			1-5/8	.444	2.230	68
E60QD68E	1145.80	16.67		C1	2-13/16	3-7/64	6	9/16	3/16	1/8	5/16	1-5/8	.444	2.230	72
E60QD76E	1352.80	18.58		C1											88
E60QD95E	1913.40	23.12	3-1/2	C1	2-13/16	3-7/64	6	9/16	3/16	1/8	5/16	1-5/8	.444	2.230	114

Harden per tooth\$ 1.56

QD Bushing dimensions and prices page 10

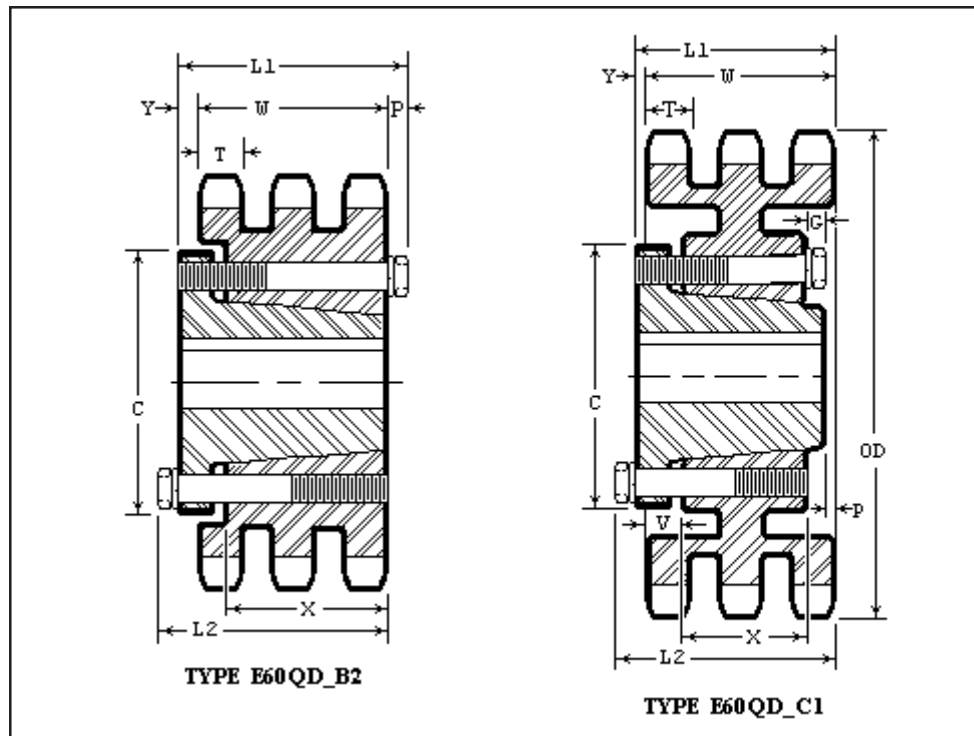



RYLE Manufacturing Company 1-800-433-0960

No. 60-3 Triple Strand 3/4" Pitch

RYLE P/N	LIST PRICE	NO. TEETH	O.D. TEETH	STOCK BORE	MAX BORE	HUB DIA.	LTB	LBS
E60B11H	134.40	11	3.00	1	1-1/4	2-1/16*	3-1/4	2.5
E60B12H	138.40	12	3.25	1	1-7/16	2-3/8 *		3.3
E60B13H	150.00	13	3.49	1	1-1/2	2-1/4	3	3.9
E60B14H	154.00	14	3.74	1	1-3/4	2-1/2		4.5
E60B15H	159.80	15	3.98	1	1-7/8	2-13/16		5.4
E60B16H	167.20	16	4.22	1	2	3		6.5
E60B17H	177.20	17	4.46	1	2-1/4	3-1/4		7.7
E60B18H	186.00	18	4.70	1	2-3/8	3-1/2		8.5
E60B19H	195.80	19	4.95	1	2-1/2	3-11/16		9.3
E60B20H	210.40	20	5.19	1	2-1/2	3-3/4		10.4
E60B21H	223.00	21	5.43	1	2-3/4	4-1/8		11.8
E60B22H	230.00	22	5.67	1		4-1/4		13.2
E60B23H	236.80	23	5.91	1				14.6
E60B24H	243.40	24	6.15	1				15.8
E60B25H	250.00	25	6.39	1				17.0
E60B26	262.00	26	6.63	1				18.6
E60B30	358.20	30	7.59	1				23.2
E60B35	437.40	35	8.78	1-1/4			3-1/4	36.0
E60B36	449.40	36	9.02					37.0
E60B42	571.80	42	10.46				3-1/2	48.5
E60B45	625.20	45	11.18					56.6
E60C52	785.40	52	12.85					80.0
E60C60	914.40	60	14.76					92.0
E60C68	1048.00	68	16.67		3-5/16	5		105.0
E60C72	1143.60	72	17.63					111.0
E60C76	1214.80	76	18.58	1-1/2				117.0
E60C95	1695.20	95	23.12		3-3/4	5-1/2	4	146.0

* Indicates hub diameter is grooved for chain clearance.

Note: 25 teeth or less already have Hardened Teeth.

Maximum bores will accommodate standard keyway and setscrew over key. Slightly larger bores may be possible with shallow keyway and/or setscrew at 90 degrees. Multiple keyways must be priced at factory.

Rebore	\$49.00
Keyway	\$13.40
Setscrew (each)	\$13.40
Harden per tooth	\$ 1.56

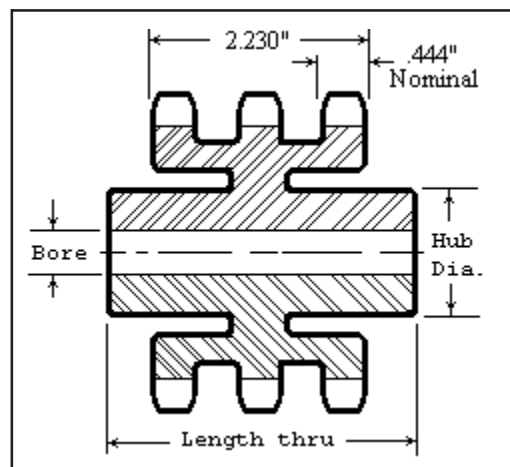
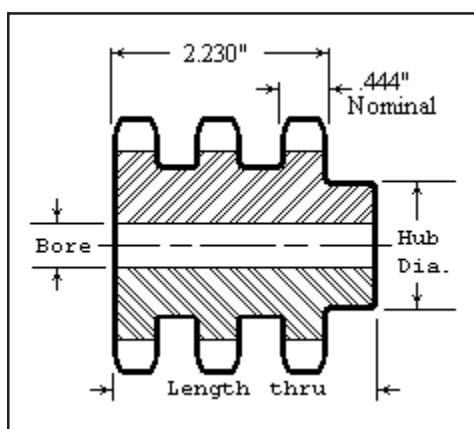



RYLE Manufacturing Company 1-800-433-0960

No. 60-4 Quadruple Strand 3/4" Pitch

RYLE P/N	LIST PRICE	NO. TEETH	O.D. TEETH	STOCK BORE	MAX BORE	HUB DIA.	LTB	LBS.
F60B13H	312.00	13	3.49	1	1-1/2	2-1/4	4	5.7
F60B14H	322.00	14	3.74	1	1-3/4	2-1/2		6.3
F60B15H	346.00	15	3.98	1	1-7/8	2-13/16		7.5
F60B16H	376.00	16	4.22	1	2	3		8.8
F60B17H	412.00	17	4.46	1	2-1/4	3-1/4		10.0
F60B18H	446.00	18	4.70	1	2-3/8	3-1/2		11.0
F60B19H	486.00	19	4.95	1	2-1/2	3-11/16		13.0
F60B20H	522.00	20	5.19	1	2-3/4	4		15.0
F60B21H	554.00	21	5.43	1		4-1/8		16.0
F60B22H	570.00	22	5.67	1-1/4	3	4-1/2		18.0
F60B23H	618.00	23	5.91					20.0
F60B24H	686.00	24	6.15					21.0
F60B25H	720.00	25	6.39					23.0
F60B26H	782.00	26	6.63		3-1/4	5	4-1/4	25.0
F60B30	810.00	30	7.59					35.0
F60B35	952.00	35	8.78					48.0
F60B36	1008.00	36	9.02					50.0
F60B40	1186.00	40	9.98					64.0
F60B45	1500.00	45	11.18					78.0
F60B52	1808.00	52	12.85					97.0
F60C60	2434.00	60	14.76	1-1/2	3-1/2	5-1/4	4-1/2	78.0
F60C68	2590.00	68	16.67					80.0
F60C72	3024.00	72	17.63					84.0
F60C80	3370.00	80	19.54					95.0
F60C95	3990.00	95	23.12		3-5/8	5-1/2	4-3/4	114.0

Maximum bores will accommodate standard keyway and setscrew over key. Slightly larger bores may be possible with shallow keyway and/or setscrew at 90 degrees. Multiple keyways must be priced at factory.

Note: 26 teeth or less already have Hardened Teeth.

Rebore	\$49.00
Keyway	\$13.40
Setscrew (each)	\$13.40
Harden per tooth	\$ 1.56

